



ASTON MARTIN

RAPIDE*S*

Aston Martin Owners' Club (AMOC)

An invitation to join the Aston Martin Owners' Club

The sporting spirit of the 1930s exists today in one of the world's most exclusive car clubs. Enthusiasts in nearly 60 countries are united by an interest in iconic cars with an enviable pedigree. Enjoy the company of like-minded owners in a wide range of activities: social evenings, weekends away or motoring tours. Something more competitive? AMOC Concours are a benchmark for connoisseurs of fine motorcars. A need for speed? We organise track days, sprints and hill climbs as well as circuit racing in venues such as Silverstone, Goodwood and Lime Rock in the USA.



Aston Martin Owners' Club

Drayton St. Leonard

Wallingford

Oxfordshire

England

OX10 7BG

Telephone:

+44 (0) 1865 400 400

Facsimile:

+44 (0) 1865 400 200

E-Mail:

hqstaff@amoc.org

Website:

www.amoc.org



Aston Martin Heritage Trust

The Aston Martin Heritage Trust is an educational charity dedicated to the preservation, promotion and enhancement of over 100 years of history of Aston Martin. Its world class collection comprising the automotive museum, substantial archive and collection of historical artefacts is housed in the magnificently restored Grade II* listed barn in Oxfordshire which it shares with the Owners' Club. As a member of the Owners' Club you become a member and supporter of the Trust, so please log on to our web site for more information, or better still pay us a visit and see the collection for yourself.



Aston Martin Heritage Trust

Drayton St. Leonard

Wallingford

Oxfordshire

England

OX10 7BG

Telephone:

+44 (0) 1865 400 414

Facsimile:

+44 (0) 1865 400 200

E-Mail:

secretary@amht.org.uk

Website:

www.amht.org.uk



Introduction	1
Vehicle Security	2
Before Driving.....	3
Controls	4
Driving.....	5
Infotainment	6
Climate Control.....	7
Audio.....	8
Rear Seat Entertainment.....	9
Hands-Free Phone	10
Satellite Navigation	11
Maintenance.....	12
Specifications	13
Service	A
Aston Martin Warranty	B
Aston Martin Assistance.....	C
Alphabetical Index	D

Every effort has been made to make sure that the information provided in this Owner's Guide is accurate and up-to-date. However neither the manufacturer or the Dealer, by whom this Owner's Guide is supplied, will in any circumstances be held responsible for any inaccuracy or the consequences thereof. All rights reserved.

No part of this publication may be reproduced, stored in a retrieval system or transmitted, in any form, electronic, mechanical, photocopying, recording or other means without prior written permission from Aston Martin Lagonda Limited.

The manufacturer reserves the right to vary specifications without notice in accordance with its policy of continual product improvement.

Produced by the Technical Publications Department
Aston Martin Lagonda Limited
Banbury Road
Gaydon
Warwick
CV35 0DB
England
Telephone:
+44 (0)1926 644300

Issue 2: December 2016
Part Number: HD43-19A321-AA

Introduction

Welcome	1.2
Warnings, Cautions and Notes	1.3
Component Location	1.4
Vehicle Identification	1.4
Data Recording	1.5
Reporting Safety Defects	1.5
Vehicle Provenance.....	1.5



Welcome

Welcome to your new Aston Martin Rapide S.

This Owner's Guide, along with other publications included in your literature pack, provides information which will enhance your pleasure from owning and driving your Aston Martin.

This Owner's Guide has been designed to explain the vehicle's operation and to make the control of its systems easy to understand and operate. All new owners are recommended to carefully study the contents of this Owner's Guide prior to driving.

This Owner's Guide forms part of the essential vehicle equipment for homologation purposes and must stay with the vehicle at all times.

To further assist the driver a location guide is located on the passenger side 'A' panel. This is a quick reference guide to show the location of the major items on the vehicle.

Aston Martin Franchise Dealers

A full list of Aston Martin Dealers worldwide, where sales and service are provided by companies with the facilities, knowledge and factory trained personnel can be found at:

www.astonmartin.com

Every effort is made to make sure that the information given in the dealer list is accurate and up-to-date. However changes amongst holders of the Aston Martin franchise can occur. Neither Aston Martin nor any listed Importer or Dealer shall in any circumstances be held liable for any inaccuracy, or the consequences thereof.

Dealers listed all aim to conform to Aston Martin standards of excellence in both sales and service. However, all vehicles sold as Aston Martins are required to meet local legislation requirements.

Should service be required in a country other than that in which this vehicle was originally purchased, every effort will be made to meet the owner's requirements, but the availability of certain parts may be affected by differences in vehicle and component specifications.

If the nearest Aston Martin Dealer is unable to help, contact Aston Martin directly:

Aston Martin Lagonda Limited

Banbury Road

Gaydon

Warwick

CV35 0DB

England

Telephone:

(+44) (0)1926 644300

Aston Martin Dealers are independent traders, they are not the Company's Agents, and therefore have no authority to bind the Company or to enter into any financial or other commitments on the Company's behalf.

Only Aston Martin Dealers are authorised to carry out warranty work.

Aston Martin Authorised Body Repairers

A full list of Aston Martin Authorised Body Repairers worldwide can be found at:

www.astonmartin.com

All Aston Martin Approved Body Repair centres have been assessed and audited to Aston Martin Body Repair Centre standards in either Category A or B.

Category A: Repairs to the bonded aluminium structure and all paint related and light structural damage.

Category B: All paint related and light structural damage.

Every effort is made to make sure that the information given in the Aston Martin Authorised Body Repairers list is accurate and up-to-date. However changes can occur. Neither Aston Martin nor any Aston Martin Authorised Body Repairer shall in any circumstances be held liable for any inaccuracy, or the consequences thereof.

Aston Martin Authorised Service Centres

A full list of Aston Martin Authorised Service Centres can be found at:
www.astonmartin.com

All Aston Martin Approved Service Centres have been assessed and audited to Aston Martin standards.

Every effort is made to make sure that the information given in the Aston Martin Authorised Service Centres list is accurate and up-to-date. However changes can occur. Neither Aston Martin nor any Aston Martin Authorised Service Centre shall in any circumstances be held liable for any inaccuracy, or the consequences thereof.

Warnings, Cautions and Notes

The following Warnings, Cautions and Notes are used within this Owner's Guide to call your attention to specific types of information.

Warnings

 **Warning: Provided to show procedures which must be followed precisely to help avoid the risk of personal injury.**

Cautions

 **Provided to show procedures which must be followed precisely to reduce the possibility of damage to your vehicle.**

Notes

 *Provided to show procedures which will help to avoid difficulties in the operation of your vehicle.*

Component Location

All directions for locating components are described as viewed from the driver's seat, i.e. the fuel filler flap shown on this diagram will be described as 'located at the rear left side of the vehicle'.



Vehicle Identification

The Vehicle Identification Number (VIN) is shown in the left side bottom corner of the windscreen.

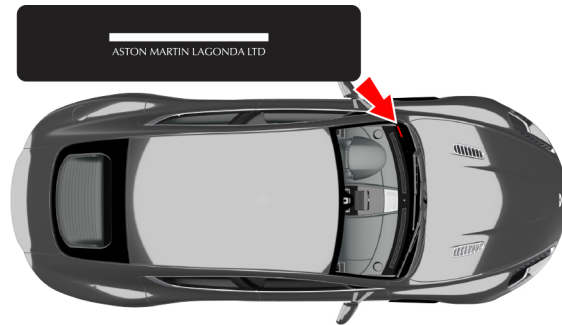

The VIN plate located in the engine bay (viewed from above) is model and market dependent:

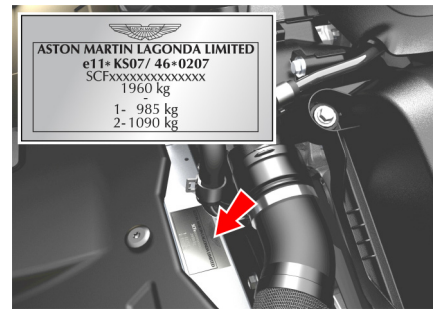

The VIN is also stamped into the floorpan in the right side footwell.

 To view the VIN stamped into the floorpan lift the carpet up, from the front, and then lift the sound deadening material.

Data Recording

Electronic modules in this vehicle are able to record detailed data, such as:

- The use of restraint systems, including seat belts by the driver and passengers.
- Information about the performance of various systems and modules in the vehicle.
- Information related to engine, throttle, steering, brake or other system status.

Any of these systems can include information on how the driver operates the vehicle, measuring vehicle speed, steering input, brake and throttle application. This information may be stored under regular operation, in a crash or in a near crash event.

This information can be read and used by:

- Aston Martin
- Service and repair facilities
- Law enforcement or government agencies
- Others who may assert a right or obtain your consent to know such information.

Reporting Safety Defects

If you believe that your vehicle has a safety defect which could cause a crash or could cause injury or death, you should immediately inform your Aston Martin Dealer or the Aston Martin Client Services at the address shown.

Aston Martin Lagonda Limited
Client Services
Banbury Road
Gaydon
Warwick
CV35 0DB
England
Telephone:
+44 (0)1926 644700

Vehicle Provenance

Model:

Body Colour:

Interior Colour:

Fascia Colour:

Vehicle Identification Number:

As on the VIN plate

First Owner:

Selling Dealer

Delivery Date

Third Owner:

Selling Dealer

Delivery Date

Fifth Owner:

Selling Dealer

Delivery Date

Second Owner:

Selling Dealer

Delivery Date

Fourth Owner:

Selling Dealer

Delivery Date

Sixth Owner:

Selling Dealer

Delivery Date

Vehicle Security

Introduction	2.2	Deadlocking.....	2.11
Aston Martin Tracking	2.2	Automatic Lock	2.11
Emotion Control Unit.....	2.5	Approach Light.....	2.12
Emergency Key.....	2.6	Homesafe	2.12
Unlocking and Opening.....	2.7	Alarm	2.13
Locking	2.8	Reduced Guard.....	2.13
Master Locks	2.8	Immobiliser	2.14
Boot Lid	2.10	Garage Door Opener	2.15

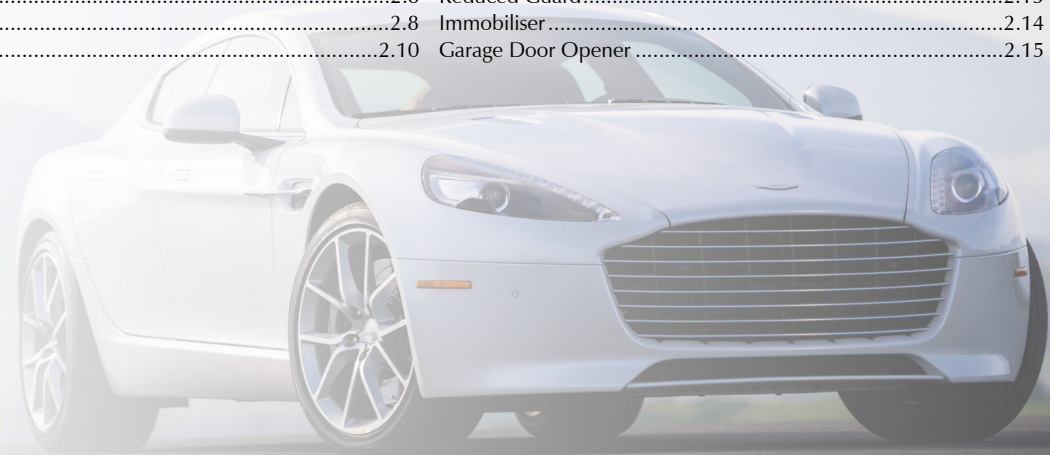

Introduction

This vehicle is protected by an electronic security system which includes:

- Remote arm and disarm
- Perimeter sensing
- Remote door, boot lid, fuel flap release lock and unlock
- Guard reduction mode
- Alarm siren with battery backup (Only in markets where audible sirens are permitted.)
- Random code encryption to prevent electronic scanning of the vehicle key identity code
- Engine Immobiliser
- Interior movement and tilt sensor (Option).

When the security system is armed, any attempt to forcibly open a door, the boot lid or the bonnet will result in full alarm operation.

Aston Martin Tracking

The Aston Martin Tracking system is a stolen vehicle tracking system. It uses the latest Global Positioning System (GPS) and Global System for Mobile communications (GSM) technology providing pinpoint accuracy and unparalleled service levels.

The system, which is discretely installed in the vehicle, is an easy-to-use system that provides the following important features:

Automatic Driver Recognition

Alerts the Aston Martin Tracking Secure Operating Centre immediately if your vehicle is stolen, even if the thief has your keys.

Engine Start Inhibit

Activated by the Secure Operating Centre with Police authorisation, to prevent the engine from being restarted.

Tamper Alert

Activated when the system battery is disconnected or discharged, or when the system wiring is cut.

Tow-Away Alert

Triggered when motion is detected with the ignition switched off and the driver card is not present.

System Health Check

Regular automatic self diagnostic check.

Transport Mode

Set by the Secure Operating Centre when the vehicle owner has confirmed the vehicle is being transported. This will prevent false alerts being generated.

Vehicle Servicing Mode

Set by the Secure Operating Centre when the vehicle has been given to the Aston Martin Dealer for maintenance.

Theft History

Minute by minute theft log helps Police secure convictions.

Pinpoint GPS Tracking

Accurate to within 10 metres.

International GSM Coverage

Roaming SIM card gives coverage across more than 180 countries.

European Coverage

Local language Police liaison and stolen vehicle recovery across Europe.

Countries covered by Aston Martin Tracking System:

Albania, Austria, Belarus, Belgium, Bosnia and Herzegovina, Bulgaria, Croatia, Cyprus, Czech Republic, Denmark, Estonia, Finland, France (Monaco), Germany, Greece, Hungary, Ireland, Italy (Vatican City, San Marino), Latvia, Lithuania, Luxembourg, Macedonia, Malta, Montenegro, Netherlands, Norway, Poland, Portugal, Romania, Russia, Serbia, Slovakia, Slovenia, South Africa, Spain (Andorra, Gibraltar), Sweden, Switzerland (Liechtenstein), Turkey, Ukraine and United Kingdom.

Insurance Accreditation

Conforms to the highest European accreditations for stolen vehicle tracking systems - Thatcham, Incert (formerly Assuralia) and SCM and is approved by major insurers.

Aston Martin Approved

The only vehicle tracking system approved for all Aston Martin vehicles.

How the System Works

The Aston Martin Tracking system is supplied with two unique driver cards. An authorised driver must have a driver card in their possession when using the vehicle.

 *Do not leave the driver card inside the vehicle or with the vehicle key. It should be kept in a safe place and always separately from your vehicle keys.*

The system automatically arms itself after the vehicle ignition has been switched off for 70 seconds and the driver card is out of range (approximately 3 metres).

The system will automatically disarm itself when the driver card is bought back in range of the vehicle.

If your vehicle is driven approximately 100 metres and the driver card has not been detected, a silent alert is transmitted to the Secure Operating Centre to inform the advisors of a potential unauthorised movement of your vehicle. The advisors then contact you.

To avoid an alert being generated, if the engine has been started and the driver card is not in your possession, switch the ignition off and call the Secure Operating Centre for advice.

The system will additionally:

- Send an alert if your vehicle is lifted or towed away without the keys.
- Send an alert if your vehicle battery is disconnected or discharged.
- Send an alert if the GPS antenna has been disconnected.
- Send a monthly health check message to the Secure Operating Centre to confirm full system functionality.

Please consult your Aston Martin Dealer for details and subscription rates.

If your Vehicle is Stolen

After an alert has been received, the Secure Operating Centre advisors attempt to contact you using the telephone number(s) that you supplied at the time of registration. A minimum of two telephone numbers must be provided at the time of activation of the contract.

The Police are not contacted until the advisors have spoken with you. This is to comply with Police procedures so that Police time is not wasted with false alarms.

Once the theft has been confirmed with you, the advisors will ask you to contact the Police to report the theft and to call the advisor back immediately with a Police incident number. Receipt of an alert does not constitute a confirmed theft, as Police Forces require key holder verification of a theft.

The Secure Operating Centre then liaises with the relevant Police Force to seek to recover your vehicle.

If your vehicle is outside the UK, the Secure Operating Centre work with the Police in their local language across Europe to recover your vehicle quickly.

In order to prevent your vehicle being moved following a theft, the Secure Operating Centre under instruction from the Police, may temporarily prevent the vehicle's engine from restarting.

Once the Police have secured the stolen vehicle, arrangements are made with you for the vehicle to be collected. The Police may require it to be taken to a secure compound for further investigation.

You will be liable for any statutory Police recovery and storage charges, payable directly to the Police.

Additional Information

False Alarms

To avoid unnecessary alerts, contact the Secure Operation Centre to inform them of any potential false alarm. Excessive false alerts may result in a charge.

Damage Check

If you are involved in an accident or if your vehicle battery has been disconnected for any reason (for example, body work repair or paint re-spray), you must call Aston Martin Tracking Customer Services so that they can test the system to check that it is still functioning correctly.

Change of Details

Should any of your personal details change, you must call Aston Martin Tracking Customer Services. For example:

- Changing the registration plate on the vehicle.
- Selling the vehicle.
- Change of address.
- Change of mobile phone number.
- New owner buying a pre-owned vehicle already fitted with Aston Martin Tracking System.

Contact Details

Aston Martin Tracking 24 Hour Secure Operating Centre:

0844 239 0035

Or from abroad:

+44 (0) 208 305 2026

Aston Martin Tracking Customer Services:

0844 239 0032

(Monday to Friday - 08.30 to 17.30)

Or from abroad:

0844 239 5404

 *When registering for the Aston Martin Tracking System, you are also provided with all the same details and contact numbers needed if your vehicle is stolen. Keep these details safe and not in the vehicle otherwise you will not be able to refer to it if your vehicle is stolen.*

Emotion Control Unit

The vehicle is supplied with three vehicle keys (Two Emotion Control Units); a glass key, a spare key and an emergency key.



Keep the spare key in a safe place. Do not leave a vehicle key in the vehicle when unattended.

 *If a vehicle key is lost, contact your Aston Martin Dealer.*

Vehicle Key Security Functions

[1] LOCK: Press and release for one step vehicle locking and to arm the security system. The vehicle will deadlock after 25 seconds.

Press and hold to raise the door windows at the same time (Refer to 'Deadlocking', page 2.11).

[2] UNLOCK: Press and release for one step vehicle unlocking.

Press and hold to lower the door windows at the same time (Refer to 'Unlocking and Opening', page 2.7)(Refer to 'Seat Memory Function', page 3.5).

[3] BOOT OPEN: Press once to release the boot lid catch (Refer to 'Boot Lid', page 2.10).

[4] APPROACH LIGHT: Press to set the front, rear side and interior lamps to ON (Refer to 'Approach Light', page 2.12).



Emergency Key

In the unlikely event that either the vehicle key fails to operate or the vehicle battery is fully discharged use the emergency key to lock or unlock the vehicle.

 Do not store the emergency key in the vehicle. If the vehicle battery is fully discharged you will need the emergency key to gain access to the vehicle.

Insert the emergency key in the door lock and turn fully towards the front of the vehicle, then release, to centrally lock the vehicle, disable the boot lid and fuel flap release switches. The security system will not arm.

To centrally unlock the vehicle, enable the boot lid and fuel flap release switches, turn fully towards the rear of the vehicle, then release. If the security system was armed, the alarm will start.

To stop the alarm insert the vehicle key (even if the vehicle key has lost all power) into the ignition control and move to position 'II' (ignition ON).



 If the vehicle battery is fully discharged the emergency key will only lock or unlock a door.

 Even if the vehicle key has lost all power it will start the engine if required.

 Memory seats: The front seats and door rear view mirrors will not move to a preset position if the vehicle is unlocked using the emergency key.

 If the emergency key is lost, contact your Aston Martin Dealer.

Unlocking and Opening

Stand within 5 m of the vehicle, point the vehicle key towards the vehicle and press the **UNLOCK** button. To show that the security system has been disarmed, the direction indicators will flash twice. All vehicle doors will unlock.

Push at point (A) and grab the emerging door release. Pull the door release to open the door.

If a door is opened while driving a warning sound will be heard until the door is closed.

 If preferred you can unlock the driver's door only with the first press of the button and the rest of the vehicle with a second press (Refer to 'Automatic Lock', page 2.11).

 For ease of use at night white LEDs are incorporated into the door handles. An LED will come ON in the door handles when the vehicle is unlocked. A door LED will go OFF once the door is opened. If a door is not opened the LEDs will go OFF after two minutes.



 If the vehicle has been opened using the spare key and the driver seat or door rear view mirrors have been adjusted, the seat and door rear view mirrors will move to the positions memorised by the key which is being used (Refer to 'Seat Memory Function', page 3.5).

 As the vehicle is unlocked, the interior lamps will come ON for five minutes. The lamps will go OFF 30 seconds after doors are closed or when the vehicle is started.

 If the door is left open the door puddle lamp will go OFF after eight minutes.

Unlocking From Inside the Vehicle

 **If reduced guard was not set to ON before locking the vehicle, deadlocking, interior movement and tilt sensors (optional) are enabled. Passengers will not be able to unlock a door from the inside.**

If reduced guard or automatic lock was set to ON before the vehicle was locked, one pull of a door handle will centrally unlock the doors, a second pull of the door handle will open that door.

(Refer to 'Automatic Lock', page 2.11).

(Refer to 'Reduced Guard', page 2.13).

Vehicle unlock from inside can be set to automatic unlock when the vehicle key is removed from the ignition control. With automatic unlock ON only one pull of a door handle will open that door.

When opening a door from inside the vehicle after reduced guard has been set to ON, the security system alarm will start. Press the **UNLOCK** button on the vehicle key to stop the alarm (there is approximately a ten second delay before the alarm is stopped).

Locking

! *If passengers are to stay in the vehicle after it has been locked, reduced guard must be set to ON before locking. This will let a passenger open a door from inside the vehicle.*

Make sure that all the doors, the boot lid and the bonnet are closed (the vehicle will not lock if a door is left open). Stand within 5 m of the vehicle, point the vehicle key towards the vehicle and press the **LOCK** button once to lock the doors, disable the boot lid and fuel flap release switches and arm the security system. The direction indicators will flash once as the security system is armed .

The driver's seat and both door rear view mirror positions are memorised and will be recalled the next time the vehicle is opened using the same vehicle key.

 *The security system will arm and the doors will deadlock after 25 seconds.*

 *If the vehicle is locked with the boot lid open, the vehicle will lock and arm but deadlocking, tilt and interior movement sensors (where fitted) will not operate. Close the boot lid to arm the complete security system.*

Automatic Re-locking

If the vehicle is locked and then unlocked but a door or the boot lid is not opened within two minutes, the vehicle will automatically lock and arm again.

Lock Light Settings

The vehicle direction indicators can be set to flash when the security system is both armed or disarmed.

To change the vehicle lock light settings:

1. Press the **MENU** button on the console.
2. Navigate to <SYSTEM SETTINGS> **ENTER** <Light settings> **ENTER**.
3. Select from <Lock Confirmation Indication>, or <Unlock Confirmation Indication>.
4. Select On or Off.

Master Locks

All doors, fuel flap and boot lid release switches may be locked and unlocked by using the front master lock switch (A). Press the switch to lock. Press again to unlock.

If the vehicle is locked using the master lock switch, one pull of a door handle will centrally unlock the doors, a second pull of the door handle will open that door.

The master lock switch will operate for seven minutes after the vehicle key has been removed from the ignition control, if the vehicle is not locked using the vehicle key.

The master lock switch will not operate if the vehicle has been locked from the outside.

Operation of the master lock switch will override automatic lock (Refer to 'Automatic Lock', page 2.11).



 When the vehicle is unlocked using the master lock switch the LED in each door handle will come ON (for 10 seconds or until the door is opened). This may aid access for passengers at night time.

 In the event of a vehicle accident the doors will automatically unlock.

Rear Passenger Door Lock

The rear doors can be centrally locked independently from the master lock switch. Press the rear lock switch (B) to lock the rear doors.

If the rear doors are locked using the rear lock switch, one pull of a door handle will unlock that door, a second pull of a door handle will open that door.

The rear lock switch will operate for seven minutes after the vehicle key has been removed from the ignition control, if the vehicle is not locked using the vehicle key.

 In the event of a vehicle accident the doors will automatically unlock.



Child Locks

Press the **MENU** button on the console. Navigate to <Car settings...> **ENTER** <Lock settings...> **ENTER** <Child lock enabled>. Press **ENTER** to toggle between child locks ON and OFF.

 In the event of a vehicle accident the rear doors will automatically unlock.

Boot Lid

To Open the Boot Lid

Press the **BOOT OPEN** button on the vehicle key **once** to enable the release catch, then press the boot lid button (A) and lift the lid.

 *If the vehicle is locked and armed the security system will disarm and the direction indicators will flash twice when the boot is opened. The doors will stay locked (Refer to 'Lock Light Settings', page 2.8).*





To Close the Boot Lid

Pull the boot lid down, then push the boot lid down and make sure that its catch engages. Once the catch engages, it automatically closes. If the boot lid is slammed shut, this is overridden. Press the **LOCK** button on the vehicle key to lock the lid. The direction indicators will flash once as the security system is armed (Refer to 'Lock Light Settings', page 2.8).

 *Always make sure that the boot lid is securely closed after use. The boot interior lamps will stay ON for seven minutes if the boot lid is left partially open and the vehicle key is removed from the ignition control.*

Vehicle Locked - Boot Lid Open

 ***Do not leave the vehicle key in the boot. If the boot lid is closed there will be no access to the contents of the boot.***

 *To use a battery conditioner the boot lid has to be left open (boot lid down but not latched).*

If the vehicle is locked while the boot lid is open, the vehicle will lock and arm (deadlocking, tilt and interior movement sensors¹ will not operate). If the boot lid is then closed (latched) deadlocking, tilt and interior movement sensors will operate and the whole vehicle will be locked and armed.

¹. Option.

Boot Lid Emergency Open

The boot lid can be opened from inside the boot by pulling the luminous emergency release handle (C).

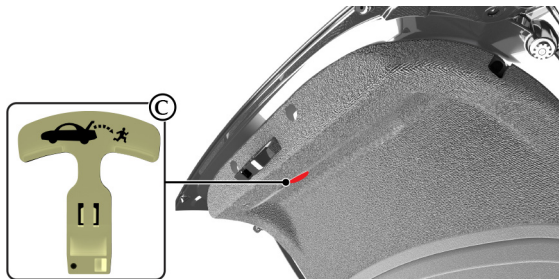

Deadlocking

⚠ If passengers are to stay in the vehicle after locking, reduced guard must be ON before locking.

The vehicle will automatically deadlock after 25 seconds after arming the security system. When the vehicle is deadlocked, the doors cannot be opened from the inside by pulling the interior door handle.

To open the doors use the vehicle key.

Automatic Lock

When automatic lock is set to ON the doors and the boot lid will automatically lock as vehicle speed reaches 7 km/h. This function prevents unwanted access to the vehicle when stopped at traffic lights, etc.

To change the automatic lock feature:

1. Press the **MENU** button on the console.
2. Navigate to <SYSTEM SETTINGS> **ENTER** <Lock settings> **ENTER**.
3. Select <Doors auto lock>, <Unlock on key out> or <Doors Unlock>. Press **ENTER** to toggle between ON and OFF.

<Doors auto lock>

Set to ON: Doors and the boot lid automatically lock when the vehicle moves off.

Set to OFF: Doors and the boot lid will not lock when the vehicle moves off.

<Unlock on key out>

Set to ON: Doors and the boot lid automatically lock when the vehicle moves off.

Set to OFF: Doors and the boot lid will not lock when the vehicle moves off.

<Doors unlock>

Select from *<All doors>* or *<Driver door, then all>* settings.

- **<All doors>**

Set to ON: All doors and the boot lid automatically lock when the vehicle moves off.

Set to OFF: All doors and the boot lid will not lock when the vehicle moves off.

- **<Driver door, then all>**

Set to ON: The driver door automatically locks first, then the passenger door and boot lid will lock.

Set to OFF: All doors and the boot lid will not lock when the vehicle moves off.

Press and hold **BACK** to accept and return to the main screen.

 *Automatic lock is factory set to ON.*

 *In the event of a vehicle accident all doors will automatically unlock.*

Approach Light

When approaching the vehicle the side and interior lamps can be set to ON by pressing the **APPROACH LIGHT** button on the vehicle key.

To change the approach light duration:

1. Press the **MENU** button on the console.
2. Navigate to *<SYSTEM SETTINGS>* **ENTER** *<Light settings>* **ENTER** *<Approach light duration>* **ENTER**.
3. Select from *<30 seconds>*, *<60 seconds>* or *<90 seconds>* duration.

Homesafe

When exiting the vehicle and the vehicle key has been removed from the ignition control, flash the main beam (pull the left side stalk up and release without latching) to set homesafe ON. The main beam and rear lamps will then stay ON for a determined amount of time and then go OFF.

To change the homesafe light duration:

1. Press the **MENU** button on the console
2. Navigate to *<SYSTEM SETTINGS>* **ENTER** *<Light settings>* **ENTER** *<Homesafe light duration>* **ENTER**.
3. Select from *<30 seconds>*, *<60 seconds>* or *<90 seconds>* duration.

Alarm

When the alarm has started a siren will be heard for a 25 seconds cycle (ten cycles maximum) and the direction indicators flash for five minutes after which the security system returns to the armed state. The doors and boot lid will stay locked throughout.

 *Markets where visible alarm signals and audible sirens are permitted.*

Stop the alarm at any time by pressing the **UNLOCK** button on the vehicle key or by inserting the vehicle key into the ignition control (position 'II'). There is approximately a ten second delay before the alarm is stopped).

 *Insert the key to position 'II' by using the flat of a finger, as shown.*

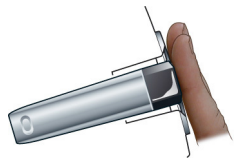

Interior Movement Sensor

Optional

When the vehicle is locked and armed the interior movement sensor will sense movement inside the vehicle. If movement is detected it will start the alarm.

Tilt Sensor

Optional

When the vehicle is locked and armed the tilt sensor will sense if the vehicle is tilted, for example, if the vehicle is being raised on a jack. If vehicle tilt is detected it will start the alarm.

Reduced Guard

 **Warning:** *If a passenger is to stay in the vehicle after it has been locked, reduced guard must be set to ON before locking. In an emergency this will let a passenger open a door from inside the vehicle.*

When reduced guard is ON, deadlocking, interior movement and tilt sensors¹ are set to OFF. This will let a passenger open a door from the inside by pulling the interior door handle and a passenger or animals to be left in the vehicle with the security system armed.

If a door is opened from the inside, while reduced guard is ON, the security system alarm will start. Press the **UNLOCK** button on the vehicle key to stop the alarm at any time.

¹. Where installed

Immobiliser

To set reduced guard:

1. Press the **MENU** button on the console.
2. Navigate to <SYSTEM SETTINGS> **ENTER** <Reduced guard> **ENTER**.
3. Press **ENTER** to select toggle between ON and OFF.
4. Then press and hold the **BACK** button on the console to accept and return to the main screen.

 *Reduced guard stays ON until the vehicle key is inserted in the ignition control and moved to position 'II' (ignition ON).*

 *If a vehicle key is lost, a duplicate key can be created and programmed from the spare key by your Aston Martin Dealer.*

Starting the Engine

When the security system is disarmed and the vehicle key is in the ignition control, the immobiliser sends a signal to the vehicle key. The vehicle key must respond with a valid code before engine start will be enabled. If a valid code is received, the ignition system will operate normally. If the vehicle key code is not received, or is invalid, engine start stays disabled.

Immobiliser Status

The immobiliser status is shown by the red symbol (A) on the instrument cluster.



Fault Mode

If the alarm symbol starts to flash at a faster rate when the alarm is not ON, then the alarm may have been previously triggered or there may be a fault. If this continues, consult your Aston Martin Dealer.

Garage Door Opener

(Option: Available with automatic dim mirror only.)

The garage door opener (HomeLink® Universal Transceiver) buttons and transceiver are on the rear view mirror. The transceiver can be programmed to operate up to three transmitters to operate garage doors, entry gates, home lights, security systems, or other radio frequency operated devices.

! As a security precaution make sure that all programming is erased in the HomeLink system before selling this vehicle.

For information or assistance, contact HomeLink at www.homelink.com or call the HomeLink hot-line:

Toll-free: (0) 0800 046 635 465

or alternatively: +49 6838 907 277 (subject to charge)

(Difficulties may be experienced trying to reach the toll-free number by some providers in certain countries .)

Alternatively, contact your Aston Martin Dealer.

 A full list of radio frequency operated devices can be either obtained via the HomeLink Hot-line or through the HomeLink compatibility list which is provided on the HomeLink website.

! Warning: Do not use the transceiver with any garage door opening system that lacks the safety stop and reverse feature as required by safety standards. A garage door opening system which cannot detect an object, signalling the door to stop and reverse increases risk of serious injury or death.

! Warning: When the transceiver is being programmed to a garage door opening system, make sure that people, the vehicle and objects are clear to prevent injury or damage as the garage door or gate will operate during the programming.

 Keep the original transmitter for future use or programming procedures if, for example, you purchase a new vehicle.

 This device may suffer from interference if operated near to a mobile or fixed station transmitter. This interference can affect the hand-held transmitter as well as the in-vehicle transceiver.

 The manufacturer is not responsible for any radio or TV interference caused by unauthorised modifications to this equipment. Such modifications could void the user's authority to operate the equipment.

Programming

 Step 1 erases all programming and is only necessary if programming HomeLink for the first time or when erasing all existing programming. It does not have to be followed to program the other HomeLink buttons.

 The HomeLink buttons can be reprogrammed individually but not individually erased. Step 1 must be completed to erase all programming.

1. Press and hold the two outer HomeLink buttons, until the HomeLink LED (A) begins to flash after 20 seconds. All three buttons are now cleared. The HomeLink system is now in setting mode.
2. Hold the remote control for the device to be programmed at a distance of 10-30 cm away from the HomeLink transmitter unit. The LED should be kept in view.

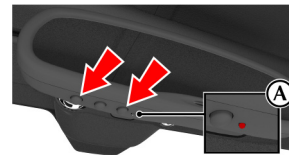

 The distance between the remote control and the transmitter unit depends on the system being programmed and several attempts at different distances may be necessary.

3. Simultaneously push the remote control button and the desired button (1, 2 or 3).
4. Using both hands, simultaneously push the remote control button and the desired button (1, 2 or 3).
5. The LED will flash, first slowly and then rapidly to show successful programming of the new frequency signal. When the LED flashes rapidly, release both buttons.

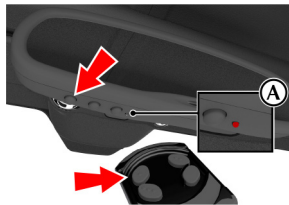

Operation

The vehicle should be within the operating range of the gate or garage door opener and the ignition should be ON.

The HomeLink system operates the garage door opener (or other device) in the same way as the original remote control.

With the system programmed, press the appropriate HomeLink button (1, 2, or 3) to operate the garage door opener.

The LED will come ON when the button on when a HomeLink button is pressed.

 The original remote control may also be used at any time.

The LED will stay ON while the garage door opener (or other device) operates. If it does not, your system may have a rolling code feature.



Rolling Code Synchronisation

To check if the garage door opener (or other device) has a rolling code feature:

- Check the garage door opener manual.
- The remote control programs the HomeLink system, but HomeLink buttons do not operate the garage door opener.
- Press and hold down the programmed HomeLink button. For a rolling code system, the LED flashes quickly and then stays ON constantly for two seconds. This pattern repeats itself for up to 20 seconds.

To programme a rolling code system, it must be synchronised with this system again before it will function correctly.

To synchronise for a rolling code:

1. Locate the training or programming button on the motor head unit for the garage door opener. Refer to the operating instructions of the garage door opener.
2. Press the training button on the motor head unit for the garage door opener. This will usually set a 'training' LED to ON.

 *There will typically be a 30 second window in which to initiate step 3.*

3. Press and release the programmed HomeLink button. Press and release the HomeLink button a second time to complete synchronisation.

 *Some systems may require this procedure to be completed a third time.*

The garage door opener should now recognise the rolling code signal and operate when the HomeLink button is pressed.

The next two buttons may now be programmed if this has not previously been done.

Reprogramming

To programme a HomeLink button to a new device:

1. Press and hold the desired HomeLink button (1, 2, or 3) for 20 seconds until the LED starts flashing slowly. Do not release the button until step 4 has been completed.
2. Hold the remote control for the device to be programmed at a distance of 10-30 cm away from the HomeLink transmitter unit. The LED should be kept in view.
3. Now press and hold the remote control button.
4. The LED will flash, first slowly and then rapidly to show successful programming of the new frequency signal. When the LED flashes rapidly, release both buttons.



ASTON MARTIN



ASTON MARTIN



ASTON MARTIN



ASTON MARTIN

Before Driving

Checks Before Driving.....	3.2	Child Safety.....	3.17
Seat Controls.....	3.2	Passenger Airbag Deactivation.....	3.19
Temperature Controlled Seats.....	3.4	ISOFIX Anchors.....	3.20
Seat Memory Function.....	3.5	Tether Anchors.....	3.21
Steering Wheel.....	3.7	Automatic Locking Retractors.....	3.22
Interior Mirrors.....	3.7	Child Seats.....	3.22
Door Mirrors.....	3.8	Boot Storage.....	3.26
Electric Windows.....	3.9	Cabin Storage.....	3.28
Restraints System.....	3.11	Accessory Sockets.....	3.30
Seat Belts.....	3.11	Ashtray and Cigar Lighter.....	3.30
Airbags.....	3.15	Reading Lamps.....	3.31

Checks Before Driving

Inspect your vehicle to make sure that everything is according to the information and specifications in this Owner's Guide.

Outside the Vehicle:

- Visually check the road wheels, nuts and tyres.
- Check that all windows, mirrors and lamps are clear and unobstructed.
- Check that the boot lid, bonnet and fuel filler flap are securely closed.
- Check the operation of all lamps.

Once Inside the Vehicle:

- Check that the doors are securely closed.
- Check that the seat, mirrors and steering wheel adjustments are correct.
- Check that all gauges and symbols are reading correctly.
- Check that all passengers have fastened their seat belts.

Seat Controls

Front Seats

⚠ Warning: Do not attempt to adjust the drivers seat whilst driving.

! The vehicle key must only be inserted into the ignition control with the two indents first, as shown. To insert the larger end first the key may damage the ignition control.



The front seats can be adjusted while the vehicle key is in the ignition control. Gently insert the vehicle key up to position '1' (press down until the instrument cluster and infotainment centre lights come ON) and release.

They can also be adjusted:

- Up to six minutes after a door is unlocked and before the vehicle key is inserted into the ignition control
- Up to six minutes after the vehicle key is removed from the ignition control

If the seat operation times out:

- Place the vehicle key in the ignition control
- Close or open a door

The seat adjustment controls are located each side of the centre console (A).



Seat Adjustment

 When making seat adjustments, i.e. moving the seat base rearwards, raising or lowering the seat base, the seat back will motor forwards whenever it approaches trim panels located behind it. If the seat back is tilted backwards the seat base will move forwards if the seat back approaches trim panels.

Driver's Seat and Passenger Seat

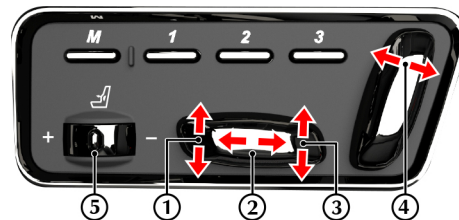

[1] : Raise or lower the **front** of the seat.

[2] : Move the seat **forwards** or **rearwards**.

[3] : Raise or lower the **rear** of the seat.

[4] : Increase or decrease the **angle of the seat back**.

[5] : Hold the thumb wheel forwards or rearwards to increase or reduce the **lumbar support**.

 The ignition must be **ON** before the heated seat and lumbar support can be operated.

Seat Head Restraints

The driver and front passenger seats include non-adjustable head restraints (B), which limit the rearward travel of the head in a rear impact and may reduce whip lash injuries. When sitting in the seats make sure that the seat back is in an upright position and that the rear of the head is positioned in the centre of the head restraint area. The head restraints are most effective when the distance between the rear of the head and the head restraint is kept to a minimum.



Rear Folding Seats

(Optional)

The rear seats back can fold down to give access to the load area or increase boot area (Refer to 'Boot Storage', page 3.26).

Press and hold (half a second) and release the seat back release button (C) for each rear seat as required. Lower the seat back until level with the boot floor.



To raise lift the seat back to its upright position, take care not to trap the seat belt, and make sure that the seat back is locked into position (button LED OFF). If the button LED stays ON the seat back is not locked in place.

If the vehicle has no power a manual release is located on the outside, behind both seat backs.

The seat backs can only be released when a rear door is open and the vehicle is at a standstill.

Grab Handle

To assist passengers in and out of the rear seats use the grab handle provided, located on both rear door pillars. A magnet holds the grab handle in place.



Temperature Controlled Seats

The front and rear seats can be cooled¹ or heated. Cooled or heated air is forced through small holes in the seat base and back. Use the individual seat controls to set the seat temperature.

[A] : Front

[B] : Rear



¹. Option.



[1] **DIAL:** Turn to raise or lower the seat temperature.

[2] **SEAT SELECT:** Press and release to select the left or right seat.

[3] **RIGHT SEAT:** When the symbol is ON use the **DIAL** to set the seat temperature.

[4] **LEFT SEAT:** When the symbol is ON use the **DIAL** to set the seat temperature.

Operation

Front and Rear Seats

The seats can be selected if the ignition is set to ON, but they will not operate until the engine is operating.

Press and release the **SEAT SELECT** button to select the left or right seat. The selected seat symbol will come ON.

Turn the **DIAL** clockwise to heat the seat or anticlockwise to reduce the heat. On vehicles with heated and cooled seats, turn the **DIAL** clockwise to heat and anticlockwise to cool the seat.

The selected seat LEDs show the level of heat (red LEDs) or cooling (blue LEDs). No LEDs shows that the temperature controlled seats are OFF.

Press and hold the **SEAT SELECT** button to set the temperature controlled seats to OFF (LEDs OFF). The system defaults to OFF at each ignition OFF.

Seat Memory Function

Warning: Make sure that there is nothing in front of, behind, or under the seat during adjustment.

Warning: To avoid injury, make sure that children do not play with the switches.

Warning: If the seat accidentally begins to move, press any seat control button to stop the seat.

The position of the driver and front passenger seats can be memorised and recalled.

Three different driving position profiles can be entered in the memory. The memory position of the driver's seat also includes both door rear view mirrors.

The memory function buttons are located in the seat adjustment controls which are located each side of the centre console (A).



Setting a Preset Position

⚠ Warning: Do not attempt to adjust the seat whilst driving.

Adjust the seat and the door rear view mirrors to the desired position. The mirror memory operates only when adjusting the driver's seat. For mirror adjustment, (Refer to 'Door Mirrors', page 3.8).

Push both the memory button (M) and the desired setting button (1, 2 or 3) simultaneously and release. A chime is heard and a message will show in the message centre to confirm¹. By repeating these steps and pressing an unused button, a second and third driving position can be stored in the memory.



 When making adjustments to a set driving position, reset the new position in the same memory channel. The previous memory is erased when a new driving position is entered.

Recalling a Memorised Position

Once in the seat press and hold button 1, 2 or 3 (depending on which position required) until all movement is stopped. The seat and door mirrors (when adjusting the driver's seat) move to the programmed position. If the button is released all movement will stop, press and hold again to continue movement.

Memory Using the Emotion Control Unit

When the vehicle is locked using the Emotion Control Unit (ECU), the driver's seat and both door rear view mirrors will remember their positions. The next time the vehicle is opened using the same ECU, the seat and door rear view mirrors will move to the memorised position once the door handle is used.

 The seat and door rear view mirrors only move if they have been moved previously, i.e. the spare ECU has been used and the seats or mirrors have been moved.

Emergency Stop

If the seat accidentally begins to move, press any seat control button to stop the seat.

¹. Driver's seat only.

Steering Wheel

⚠ Warning: Do not adjust steering wheel whilst driving.

⚠ Warning: Make sure that the steering column is fully locked in position. The reach and tilt release lever must be fully up, in line with the steering column.

Reach and Tilt

The reach and tilt angle of the steering wheel are adjusted by using the release lever (A). Pull the release lever downwards and manoeuvre the steering wheel to the required position. Hold the steering wheel in the required position and lock it by pulling the release lever up.



Interior Mirrors

Rear View Mirror

Manual Dip

Adjust the rear view mirror on its ball mounting until a satisfactory rear view is obtained.

To avoid dazzle from headlamps of following vehicles use the dip lever to raise or lower the mirror.



Automatic Dim

Adjust the mirror on its ball mounting until a satisfactory rear view is obtained.

The rear view mirror will dim automatically if the glare from the headlamps of following vehicles becomes too bright. The mirror will return to normal view as unwanted glare reduces to an acceptable level. If the mirror is dimmed when reverse gear is selected the mirror will revert to normal view.



Vanity Mirror

A vanity mirror is located in each sun visor.



Door Mirrors

To adjust the door mirrors select the left or right mirror (B). Then move the joystick (A) up, down, left or right to adjust the selected mirror.



 *The vehicle key must be at position 'I' or 'II' in the ignition control before the door mirrors can be adjusted.*

 *An amber LED shows the selected mirror.*

Heated Mirrors

When the heated rear window is ON the heaters in the door mirrors will operate for 6.5 minutes.

Power Fold Function

When the vehicle is locked using the vehicle key or master lock switch the mirrors will automatically fold in flat against the doors. They return to the driving position once the vehicle is unlocked.

This function can be enabled or disabled. Press **MENU** on the console. Navigate to <SYSTEM SETTINGS> **ENTER** <Mirror settings> **ENTER** <Powerfold mirrors>. Press **ENTER** to toggle between ON and OFF, then press and hold **BACK** to accept and return to the main screen.

Manual Fold Function

To manually fold or unfold the door mirrors:

Insert the vehicle key to position 'I' or 'II' in the ignition control. Move the mirrors to the folded or unfolded position by pressing down and releasing both the left and right mirror select switches (B) together.

 **If the mirrors are manually folded they will remain folded on unlock until 10kmph (6 mph) is reached.**

 *Door mirror vibration can occur if the mirrors have been moved manually (folded or unfolded), either intentionally or accidentally. To reset the linkage manually, operate the door mirrors once to fold or unfold the mirrors.*

Reverse Dip Function

This function gives a better view to the rear of the vehicle while reversing.

When reverse gear is selected:

Automatic Mode: When reverse gear is selected the door mirrors automatically move to the first preset dip position. If the mirror requires further lowering, press down and release the mirror joystick (A) again. If the mirror is lowered too far, press the mirror joystick up and release.

Manual Mode: Press down and release the mirror joystick (A). This will lower the door mirrors to preset position 1 dip. If the mirror requires further lowering, press down and release the joystick again. If the mirror is lowered too far, press the mirror joystick up and release.

In manual or automatic mode the mirrors return to driving view when reverse gear is de-selected or when either mirror button (B) is pressed.

Electric Windows

Reverse Mirror Dip Settings

1. Press **MENU** on the console.
2. Navigate to <SYSTEM SETTINGS> **ENTER** <Mirror settings> **ENTER** <Reverse mirror dip>.
3. Select <Passenger and driver>, <Passenger only> or <Off>.
If set to <Passenger and driver>: Both door mirrors dip automatically when reverse gear is selected.
If set to <Passenger only>: Only the passenger door mirror dips when reverse gear is selected.
If set to <Off>: The door mirrors stay in manual mode.
4. Then press and hold **BACK** to accept and return to the main screen.

⚠ Warning: Misuse of the window switches, especially by children, can result in injury due to entrapment in the window closure. Drivers must advise all passengers of the possible danger and make sure that all obstructions are clear before raising the window.

 The windows can be operated up to one minute after the vehicle key is removed from the ignition control.

Each vehicle door has its own window switch. The drivers door window switch can operate all windows and, for safety, can lock both rear door window switches.

To raise and lower the windows the vehicle key must be at ignition position 'I' or 'II'.

Lightly press and hold a window switch (A) for the drivers door or (B) for the other doors to lower the window in one movement. Lightly press and release the window switch to lower the window in stages.



Firmly press and release to lower the window with one touch.

Lightly pull back and hold to raise the window in one movement. Lightly pull back and release, to raise the window in stages. Firmly pull back and release to raise the window in one movement (only when the door is closed).¹

If a rear door window is lowered the front door window (on the same side) will also lower a few millimetres (still maintaining a water tight seal). As the rear window is raised the front window will raise.

If power to the electric windows has been interrupted for any reason, they will fail to operate correctly until reset (Refer to 'Door Window Reset', page 12.27).



¹. One movement operation will not work if the anti-trap is faulty

Window Anti-Trap

The anti-trap sensor detects an obstruction between the window glass and the door seal during window closing. The window will continue to close until the obstruction is sensed by the door seal sensor, closing then stops and the window backs off. This is a safety feature designed to prevent inadvertent closing of a window on vulnerable parts of the body or other obstructions. Remove any obstruction and then close the window.

If, for any reason it is required to override the anti-trap mechanism, lift and hold the relevant window switch until the window has closed.

Rear Door Window Lock

The rear door windows can be locked so that rear passengers can not operate them. Open or close the windows as required then press and release the rear door window lock button (C) to lock. Press and release again to unlock.



Operation with Vehicle Key

When locking or unlocking the vehicle with the vehicle key, press to lock or unlock and hold until the windows start to move, then release. The door windows will fully raise (when locking) or lower (when unlocking).

Door Sealing

⚠ Warning: Make sure that all passengers are clear when the window mechanism is operating.

To minimise wind noise and to make sure that the window seal is watertight a door sealing system is used to provide a tight fit of the door glass to the seals around the top of the door opening.

When a door is opened, the windows in both doors, on the same side, automatically lower a small distance to clear the door seal. As the door is closed, both door windows automatically, after a pause, lift against the body frame rubber seals (rear door lifts first). As the vehicle speed reaches 7 km/h the front door windows will lift a small amount again to make sure of a good water tight seal.

Restraints System

The restraints system gives protection to the driver and all passengers in a variety of impact conditions. The system consists of:

- Driver and passenger safety belts with pre-tensioners and load limiting systems
- Driver and front passenger dual-stage airbags
- Driver and passengers head airbags (door mounted)
- Driver and front passenger seat side airbags
- Front Passenger Airbag Deactivation (PAD) switch

All of these systems are controlled by a Restraints Control Module (RCM). In a collision the RCM will analyse information from various sensors, including crash and seat occupancy conditions. Based on this information the RCM will deploy the appropriate safety devices. During a crash, the RCM may or may not operate the safety belt pre-tensioner(s) and none, one, or both stages of the dual-stage airbag supplemental restraints.

If the pre-tensioners or airbags do not operate in a collision it does not mean that something is wrong with the system. Rather, it means the system determined the accident conditions (crash severity, belt usage, etc.) were not appropriate to operate these safety devices.

Front airbags are designed to operate only in frontal and near-frontal collisions, not rollovers, side-impacts, or rear-impacts unless the collision causes sufficient longitudinal deceleration.

Determining if the System is Operational

A warning symbol in the instrument cluster  shows the condition of the system. A difficulty with the system is shown by one or more of the following:

- The warning symbol will flash or stay ON.
- The warning symbol does not come ON immediately after the ignition is set to ON.

If either of these conditions occur, even intermittently, have the restraint system serviced at your Aston Martin Dealer immediately. Unless serviced, the system may not operate correctly in the event of a collision.

Seat Belts

Aston Martin strongly recommend the use of seat belts.

⚠ Warning: Seat belts should not be worn with straps twisted.

⚠ Warning: Each belt assembly must only be used by one occupant; it is dangerous to put a belt around a child being carried on the passengers lap. Do not put an adult seat belt around two children.

⚠ Warning: When installed, the seat belt webbing must not contact any sharp edges which could abrade or cut the webbing during normal use or in an accident. If necessary, the webbing must be protected.

⚠ Warning: Care should be taken to avoid contamination of the webbing with polishes, oils and chemicals, and particularly battery acid. Cleaning may safely be carried out using mild soap and water. The belt should be replaced if webbing becomes frayed, contaminated or damaged.

⚠ Warning: Wearing your seat belt is crucial to your safety. Not wearing a seat belt increases chance of serious injury or death in the event of an accident.

⚠ Warning: Be sure that you and your passengers always fasten their seat belts and use them correctly even though airbags are provided.

⚠ Warning: Reclining the seat back decreases protection provided by the seat belt in the event of a crash. Adjust the seat back to an upright position. Make sure that the seat back is locked in place. Otherwise it could move forward in the event of a sudden stop or crash and cause injury.

⚠ Warning: Seat belts are designed to bear upon the bony structure of the body, and should be worn low across the front of the pelvis, chest and shoulders; wearing the lap section of the belt across the abdominal area must be avoided.

⚠ Warning: Never place the shoulder portion of belt under your arm or behind your back.

⚠ Warning: Always remove rigid or breakable objects i.e. spectacles or a mobile phone, from your pockets. These items could be trapped under seat belts, possibly causing injury in the event of an accident.

⚠ Warning: Expectant mothers should seek medical advice on the most appropriate way to wear the seat belt.

⚠ Warning: Seat belts must be kept clean so that the retractor works correctly. Make sure that belt webbing is not twisted, looped, frayed or obstructed in any way. If in doubt about condition or operation of seat belt installation, have it checked by your Aston Martin Dealer.

⚠ Warning: No modifications or additions should be made by the user which will either prevent seat belt adjusting devices from operating, or prevent seat belt assembly from being adjusted to remove slack. Never install accessories on your seat belts.

⚠ Warning: Seat belts should be adjusted as firmly as possible, consistent with comfort, to provide the protection for which they have been designed. A slack belt will greatly reduce the protection afforded to the wearer.

⚠ Warning: It is essential to replace the entire seat belt assembly after it has been worn in a severe impact even if damage to the seat belt assembly is not obvious.

Pre-tensioner and Load Limiting

All seat belts are equipped with pre-tensioner and load limiting systems.

In most moderate frontal or near frontal accidents, the front airbag and all pre-tensioner systems will deploy simultaneously.

The pre-tensioners take up slack in the seat belts as the airbags are expanding. The load limiting system releases belt webbing in a controlled manner to reduce belt force on the passenger's chest.

 In some moderate frontal or near frontal accidents, only the pre-tensioner system will deploy.

Seat Belt Reminder

Front Passengers



A warning symbol in the instrument cluster will come ON and warning sound will be heard for six seconds (approximately) when the ignition is set to ON if the driver or front passenger¹ seat belt is not fastened. (Market area dependent.)

If the driver seat belt is not fastened after 60 seconds or if the vehicle has reached a speed of 25 km/h, a warning sound will be heard for 30 seconds, after which the warning sound will go ON and OFF and the warning symbol will continue to show until the seat belt is fastened.

Rear Passengers

If a rear door has been opened and closed the message centre will show the rear seatbelts status. The message will go OFF after 10 seconds once the vehicle has reach a speed of 7 km/h or press the **READ** button to clear the message immediately.

¹. If a passenger is sitting in the front passenger seat.

If a seat belt is unfastened during a journey the warning symbol and a message will show. The warning will stop once the seat belt is fastened or manually cleared by pressing the **READ** button.

To Disable or Enable the Rear Seat Belt Reminder

- Make sure that the ignition is set to OFF (ignition position '0') and that both rear seat belts are unfastened.
- Set the ignition to ON (ignition position 'II') and within 60 seconds fasten and unfasten a rear seat belt nine times. Finish with the belt unfastened.
- The message ENABLE/DISABLE REAR SEAT BELT REMINDER? will show in the message centre. Within five seconds fasten and unfasten the rear seat belt once more.
- The conformation message REAR SEAT BELT REMINDER ENABLED/DISABLED will show for 30 seconds.

The warning messages are always available, press the **READ** button to view stored messages.

Seat Belt Fastening



When parked on an incline, the seat belt may lock as it is withdrawn. This is not a fault. If the mechanism locks, release the belt tension and then pull the belt very gently to avoid operation of the inertia lock.

Each seat has three point, inertia reel seat belts installed. Items (1), (2) and (3) show the three points of the seat belt. Item (3) is also the location of the belt buckle.

The inertia belt reels will automatically tension the belts to provide security with comfort. In the event of a collision or during severe braking, the belt reels will lock.

Pull out the seat belt, drawing the tongue over the shoulder and across the chest.



Push the tongue into the belt buckle until a positive click is heard. Pull upwards on the diagonal belt to make sure that the latching is secure and to remove all slack from the belt.

Finally, double check that the lap belt is installed snugly, low down across the hips, and that there are no twists.

If it is necessary for a passenger to adjust their seat or seating position during a journey, the belt tension might be disturbed.

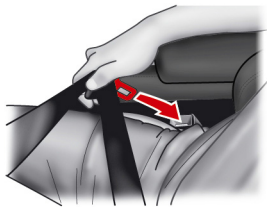

The passenger should therefore (as soon as it is safe to do so) gently pull down the shoulder run of the seat belt to create some slack and then immediately release it to re-tension the belt for the new seating position.

Seat Belt Unfastening

Push the button on the buckle. While holding the seat belt tongue allow the belt to slowly retract to its stored position.



Child Seat Belt Fastening

⚠ Warning: An infant or child that is not correctly restrained can be seriously injured or killed in a crash. Seat belts are designed for adults and larger children; infants and smaller children must be restrained in an approved child safety seat.

Make sure that there is no slack in the webbing and that the restraint installs correctly across the child's rib cage and hips. These are the parts of the body most able to take the force of impact.

The lap strap should pass across the top of the child's thighs, bearing on the pelvis, not on the abdominal area.

Airbags

Supplemental Restraints System

The vehicle is equipped with driver and passenger airbags. The airbags and seat belt pre-tensioners are electrically controlled by the restraints system.



The front airbags (A) only deploy in a serious front collision. The side airbags, located in the front seats (B) and the door top panels (C) only deploy according to which side has been impacted in a serious side collision. The airbags mounted in the door top panels on each door are designed to protect the heads of the driver and passengers during certain side impacts.



The purpose of the airbags is to provide **additional** protection for the driver and passengers in the event of a serious impact (front or side impacts). The airbags are supplementary to the seat belts.

Important airbag safety labels are located on the sun visors and on the end of the instrument panel (passenger side). Make sure that the instructions on these labels are read and complied with before driving the vehicle.

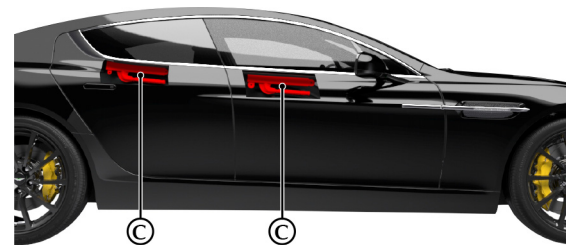

Airbag Deployment

⚠ Warning: *The use of accessory seat covers may prevent the deployment of the side airbags and increase the risk of injury in an accident. Do not use accessory seat covers.*

⚠ Warning: *All passengers, including the driver, should always wear seat belts, whether or not an airbag is provided, to decrease the risk of injury or death in the event of a crash.*

⚠ Warning: *No objects whatsoever should be attached to the centre cover of the steering wheel or the front passenger fascia panel. Such objects could cause harm if the vehicle is in a collision severe enough to cause the airbags to deploy.*

Airbags inflate rapidly and with considerable force; there is therefore a risk of death or serious injury such as fractures, facial and eye injuries or internal injuries, particularly to passengers who are not correctly restrained by seat belts or are not sitting correctly when the airbags deploy. The risk of injury from a deploying airbag is greatest close to the trim panel covering the airbag.

The whole sequence of events from sensing the impact to full inflation of the airbag takes place in a fraction of a second. The noise and gas associated with the deployment of the airbags is not injurious to health.

Do not change, modify or tamper with the steering wheel, passenger side fascia or any other part of the airbag system. Such actions could disable the system or cause inadvertent airbag deployment.

The system will not deploy in the event of minor frontal or side impacts, such as contacts when parking.

The airbag system is not designed to protect against rear impacts.

All work on the airbag system must only be carried out by an Aston Martin Dealer.

[A] : Front airbag deployment

[B] : Front seats side airbag deployment

[C] : Door airbag deployment

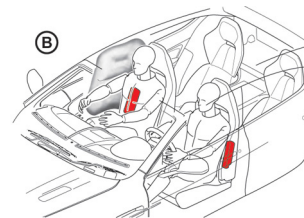
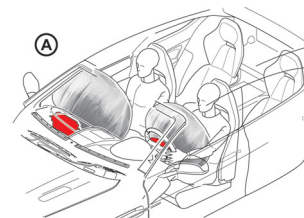

Child Safety

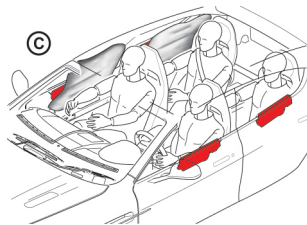

Aston Martin strongly recommends:

- Not to install any child seat on the front passenger seat of this vehicle.
- That all children are seated in the rear passenger seats.
- Always use ISOFIX anchors where available.
- A child, regardless of age, should always be restrained when travelling in a vehicle.

⚠ Warning: Accident statistics show that children are generally safer when correctly restrained in the rear seat than in the front seat. A suitable child restraint, correctly installed and used, provides the highest degree of protection for infants and small children in most accident situations.

⚠ Warning: Do not allow children to travel in a vehicle without being correctly restrained. An appropriate child seat or harness should always be used.

⚠ Warning: Each seat belt assembly must be used by only one passenger. It is dangerous to put a seat belt around a child being carried on the passengers lap.

⚠ Warning: Make sure that an installed child seat does not rest against the door, that the child sits correctly in the seat and does not lean close to, or against, the door or window.

Your vehicle has the following devices for the installation of child restraints:

- Passenger Airbag Deactivation (PAD) switch
- ISOFIX anchors (Rear passenger seats only)¹
- Passenger seats Automatic Locking Retractor (ALR) seat belts
- Tether anchor points (Rear passenger seats only)

¹. Standard for installing child seats into cars and is intended to make the installation of child seats quick and simple.

Child Seats and Front Passenger Airbag

⚠ Warning: Do not place a child restraint on a seat with an active airbag.

⚠ Warning: With the exception of installing a child seat on the front passenger seat, do not set the PAD switch to OFF, as the front passenger will not receive the added protection of the airbag. Serious injuries or even death could occur.

If a child seat is to be used in the front passenger seat, the front passenger airbag **must** be set to OFF. Make sure that the child seat manufacturer's installation instructions are followed correctly.

In the event of a serious frontal or side collision the vehicle airbag system is designed to deploy, to provide additional protection for the front seat occupants.

 The PAD switch does not set the front passenger side impact airbags or the seat belt pre-tensioners to OFF.

Warning Labels

⚠ Warning: Extreme Hazard: NEVER use a rearward facing child restraint on a seat protected by an ACTIVE AIRBAG in front of it. DEATH or SERIOUS INJURY to the Child can occur.

The following warning labels (market area dependent) are located on both sides of the sun visor and on the end of the instrument panel (passenger side).



Child Safety Locks

When the child locks are ON the rear doors can not be opened from the inside.

Press the **MENU** button on the console and select <Child lock enabled>. Press **ENTER** to toggle between child locks ON and OFF.

 In the event of a vehicle accident the rear doors will automatically unlock.

Passenger Airbag Deactivation

⚠ Warning: Before installing a child seat on the front passenger seat, the front passenger airbag must be set to OFF.

⚠ Warning: Before driving always confirm that the PAD switch is in the appropriate position according to your requirements.

⚠ Warning: With the exception of installing a child seat on the front passenger seat, do not set the PAD switch to OFF, as the front passenger will not receive the added protection of the airbag. Serious injuries or even death could occur.

 The PAD switch does not set the front passenger seat side impact airbags or the seat belt pre-tensioners to OFF.

The Passenger Airbag Deactivation (PAD) switch lets the airbag protecting the front passenger be set to OFF. When the PAD is set to OFF a child seat may be installed on the front passenger seat. At ignition ON, if the front passenger airbag is set to OFF, PASS AIRBAG OFF will show in the message centre.

The PAD switch is located on the passenger end of the instrument panel and is accessible when the front passenger door is open.



The PAD switch should be inspected by an Aston Martin Dealer if any of the following conditions occur:

- The PAD warning symbol does not come ON (for six seconds) when the ignition is set to ON and the passenger airbag is set to ON.
- The PAD warning symbol does not stay ON when the ignition is set to ON and the passenger airbag set to OFF.
- The PAD warning symbol stays ON when the ignition is set to ON and the passenger airbag is set to ON.

Set the Airbag to ON or OFF

Insert the emergency vehicle key into the PAD switch and turn clockwise for the OFF position (airbag OFF) or counterclockwise for the ON position (airbag ON). Remove the key.

Airbag ON

When the ignition is set to ON make sure that the PASS AIRBAG OFF symbol (A) comes ON for six seconds then goes OFF. Failure to follow the advice given above can endanger the life of the child.

Airbag OFF

Make sure that the PASS AIRBAG OFF symbol stays ON when the ignition is ON.



ISOFIX Anchors

⚠ Warning: An unsecured child seat is dangerous. In a sudden stop or a collision it could move, causing serious injury or death to the child or other passengers. Make sure the child seat is correctly secured in place according to the manufacturer's instructions.

⚠ Warning: When installing the child seat, make sure that there are no seat belts or foreign objects near or around the ISOFIX anchors. If seat belts or a foreign object prevents the child seat from being securely attached to the ISOFIX anchors, the child seat could move in a sudden stop or collision causing serious injury or death to the child or other passengers.

This vehicle is equipped with ISOFIX (International Standards Organisation FIX) anchors for the installation of child seats on the passenger seat. The anchors are located between the seat base and the seat back.

 Move the seat rearwards, to allow clearance for installing the child seat.

Secure the child seat using the ISOFIX anchors, following the child seat manufacturer's instructions.

⚠ Warning: An unsecured child seat is dangerous. In a sudden stop or a collision it could move, causing serious injury or death to the child or other passengers. Make sure the child seat is correctly secured in place according to the manufacturer's instructions.

⚠ Warning: When installing the child seat, make sure that there are no seat belts or foreign objects near or around the ISOFIX anchors. If seat belts or a foreign object prevents the child seat from being securely attached to the ISOFIX anchors, the child seat could move in a sudden stop or collision causing serious injury or death to the child or other passengers.

This vehicle is equipped with ISOFIX (International Standards Organisation FIX) anchors for the installation of child seats on the rear passenger seats. The anchors are located between the seat base and the seat back. The position of the anchors is shown by two tags at the base of each rear seat.



Remove the lower seat back panel (A). Place the panel in its storage area in boot.

 The seat back trim panels are left and right handed.

Secure the child seat using the ISOFIX anchors (B), following the child seat manufacturer's instructions.

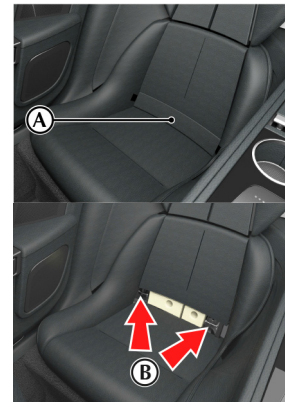

Tether Anchors

⚠ Warning: An infant or child that is not properly restrained can be seriously injured or killed in a crash. Seat belts are designed for adults and larger children; infants and smaller children must be restrained in an approved child safety seat.

⚠ Warning: Make sure that the child seat tether strap is always used when installing a child seat with ISOFIX anchors.

⚠ Warning: Child restraint anchorages are designed to withstand only those loads imposed by correctly installed child restraints. Under no circumstances are they to be used for adult seatbelts, harnesses or for attaching other items or equipment to the vehicle.

⚠ Warning: Always follow the child seat manufacturer's instructions. Not following the child seat manufacturer's instructions when installing the child seat is dangerous.

⚠ Warning: Make sure the child seat tether strap is free from obstructions above and below. Do not place any items on the tether strap between the child seat and the tether anchor point. Do not place tether strap over any items between the child seat and the tether anchor point.

A tether is a strap that connects the top of a child seat to a tether anchor point on the vehicle to reduce excessive movement of the child seat in the event of a collision. The purpose of a tether strap is to provide additional protection for the child seat occupant in the event of a serious impact. The tether strap is supplementary to the seat belts.

Your vehicle has a tether anchor point for each rear passenger seat.

Correct Assembly of Tether Anchorages

The tether anchor point is located at the rear of the boot area (A). The boot space area must be configured as configuration two (Refer to 'Boot Storage', page 3.26).

Route the tether strap through the seat back as shown. Engage the tether clip to the anchor point as shown and make sure that the locking spring has fully closed to prevent accidental disengagement.

Always make sure that the tether strap length is adjusted to remove any slack.

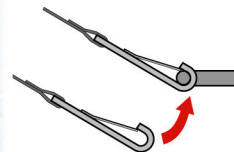
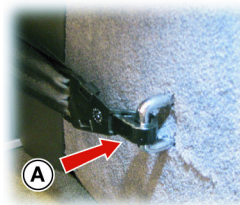

Automatic Locking Retractors

⚠ Warning: Always follow the child seat manufacturer's instructions. Not following the child seat manufacturer's instructions when installing the child seat is dangerous.

Aston Martin does not recommend any specific child seat for this vehicle **which requires the use of the vehicle seat belt for installation.**

The Automatic Locking Retractor (ALR) system is designed to securely hold child seats. The ALR system temporarily locks the seat belt that is securing a child seat.

ALR Operation

Gently pull out the seat belt until fully extended. The ALR system will only engage at the maximum extension point of the seat belt.

Thread the belt tongue through the child seat as instructed by the child seat manufacturer. Engage the tongue into the belt buckle.

Adjust the tongue position on the belt, if necessary, to make sure that the lower belt run is tight and then allow the upper run of the seat belt to fully retract until the child seat is securely held. The ALR system will be heard 'clicking' as the seat belt retracts.

When fully retracted, pull down on the upper run of the belt to check that the ALR lock has engaged.

 *When parked on an incline, the seat belt may lock as it is withdrawn. This is not a fault. If the mechanism locks, release the seat belt tension and then pull the seat belt very gently to avoid operation of the inertia lock.*

The ALR system will disengage when the seat belt is fully retracted. The seat belt may then be worn when required as a normal seat belt. Once the ALR is disengaged, the seat belt must be fully extended to re-engage the system on the next occasion that a child seat is installed.

Child Seats

⚠ Warning: Always follow the child seat manufacturer's instructions. Not following the instructions when installing the child seat is dangerous.

⚠ Warning: Do not seat a child aged 12 or younger, or weighing 36 kg or less in the car without an appropriate child seat or booster cushion.

Aston Martin strongly recommends not to install any child seat on the front passenger seat of this vehicle.

Aston Martin recommends the installation of Aston Martin child seats, which use ISOFIX. Contact your Aston Martin Dealer for more information on Aston Martin child seats.

Use of Child Seats

When installing child seats on the rear seat(s) make sure that there is sufficient room between the front seat back and the child seat, if required move the front seat forward. When installing the BabySafe Plus and ISOFIX base make sure that there is at least a 5 cm gap between the child restraint and the front seat (A).

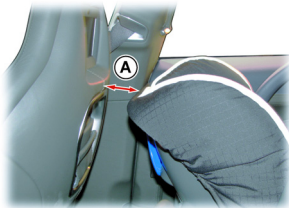

Look for the following when selecting a child seat:

- It should have a label certifying that it meets the applicable Safety Standards.
- Carefully read the instructions supplied with the child seat. Make sure you understand them and can install and use the device correctly and safely in the vehicle.
- Make sure that the child seat is appropriate for the child's weight and development. The label required by the standard or regulations, or instructions for infant seats, usually provide this information.

An infant or child that is not correctly restrained can be seriously injured or killed in a crash. Seat belts are designed for adults and larger children; infants and smaller children must be restrained in an approved child seat.

Children can be seriously injured in a crash if their child seat is not correctly secured in the vehicle.

Never hold a baby or child on your lap while riding in the vehicle.

Consult with local manufacturers of forward facing restraint and booster cushions. These manufacturers can supply you with advice on the safety of their particular child restraints.

Check the seat manufacturer's instructions for correct use and installation – use the correct size seat and correctly secure the seat in the vehicle in accordance with the manufacturer's instructions. Be sure to read and follow the 'Installation and Use Instructions' provided with the child seat.

Child Seats - ISOFIX Installation

Always follow the child seat manufacturer's instructions. Not following the child seat manufacturer's instructions when installing the child seat is dangerous.

Mass Group ₁	Size Class	Fixture	ISOFIX Positions	
			Front Passenger	Rear Outboard
Carry Cot	F	ISO/L1	X	X
	G	ISO/L2	X	X
'0'	Up to 10 kg (0-9 months)	E	ISO/R1	X
'0+'	Up to 13 kg (0-18 months)	E	ISO/R1	X
		D	ISO/R2	X
		C	ISO/R3	X

¹. As shown on the child safety seat packaging

². Aston Martin branded Britax Baby - Safe Plus II

Mass Group ₁	Size Class	Fixture	ISOFIX Positions	
			Front Passenger	Rear Outboard
'I'	9 to 18 kg (9 months to 4 years)	D	ISO/R2	X
		C	ISO/R3	X
		B	ISO/F2	X
		B1	ISO/F2X	X
		A	ISO/F3	X
'II'	15 to 25 kg (4 to 12 years)		X	X
'III'	22 to 36 kg (4 to 12 years)		X	X

¹. As shown on the child safety seat packaging

². Aston Martin branded Britax Baby - Safefix Plus

Table Key

IUF: Suitable for 'ISOFIX' forward child restraints systems of universal category approved for use in the mass group.

IL: Suitable for particular ISOFIX Child Restraint Systems (CRS). These ISOFIX CRS are those of the 'specific vehicle', 'restricted', or 'semi-universal' categories.

X: ISOFIX position not suitable for ISOFIX child restraint systems in this mass group or this size class.

Supplied under ECE Regulation 16.

Child Seats - Seat Belt Installation

Consult with local manufacturers of forward facing restraint and booster cushions. These manufacturers can supply you with advice on the safety of their particular child restraints and also advice on installation instructions.

Mass Group ¹		Seating Position	
		Front Passenger	Rear Outboard
'0'	Up to 10 kg (0-9 months)	U ₂	U
'0+'	Up to 13 kg (0-18 months)	U ₂ .	U
'1'	9 to 18 kg (9 months to 4 years)	U ₂ .	U
'II'	15 to 25 kg (4 to 12 years)	U ₂ .	L ₃
'III'	22 to 36 kg (4 to 12 years)	U ₂ .	U

- As shown on the child safety seat packaging
- Move the passenger seat to its rearmost and highest position.
- Mass Group II - Aston Martin branded Britax Kidfix ISOFIT (Refer to 'Britax Kidfix ISOFIT Child Seat', page 3.26)

Table Key

L: Suitable for particular child restraint systems. These restraints may be of the 'specific vehicle', 'restricted' or 'semi-universal' categories.

U: Suitable for 'universal' category restraints approved for this mass group.

X: Seat position not suitable for children in the mass group.

*****: Unsuitable for use with many child restraints due to limited space.

Supplied under ECE Regulation 16.

Britax Kidfix ISOFIT Child Seat

Aston Martin branded.

⚠ Warning: *The lap or diagonal seat belt is only to be used to restrain the child in the child seat. Do not use the lap or diagonal seat belt to install the child seat. Always use the Britax Kidfix ISOFIT child seat ISOFIT latches.*

Rear Seat Install

Install the Britax Kidfix ISOFIT child seat to the rear seat ISOFIX anchors as per the manufacturer's instructions and make sure that there is sufficient room between the front seat back and the child seat, if required move the front seat forward. Adjust the height of the child seat headrest as required according to the manufacturer's instructions. **Make sure that the headrest does not come into contact with the rear door top trim panel.**

Boot Storage

The boot area can be configured to let various small or large items be placed in the boot.

Configuration (1)

Lift the boot divide panel up.

With the boot divide panel raised and the parcel shelf in place items placed in the boot are hidden from view.



Configuration (2)

Lay the boot divide panel down to give more space for larger items.

 *The rear seats can also be lowered to increase the load area¹. (Refer to 'Rear Folding Seats', page 3.4)*



¹. Rear folding seat option only.

Parcel Shelf

The parcel shelf has two lugs which locate into the boot lid and two magnets which hold the shelf in place.

To remove the parcel shelf, pull the base away from the glass by two or three centimetres (A) to release it from the magnets. Gently lower the shelf away from the boot lid to release the two lugs (B). To install the shelf insert the two lugs into the boot lid and bring the top of the shelf up to the boot lid until the magnets hold the shelf in place.

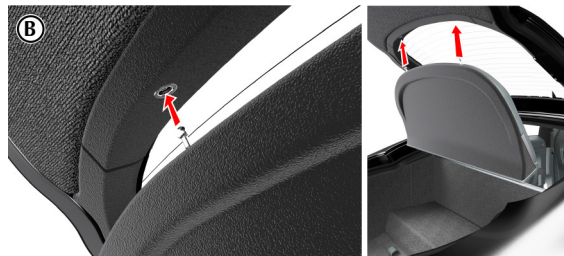

When not in use, the parcel shelf locates in the boot floor space with the two leather straps facing down, and the two lugs facing the boot rear, as shown (C).



Cabin Storage

Glove Box

Press the glove box button (A) to open. Push up to close.



Cup Holders

⚠ Warning: Only use the cup holder when safe to do so.

⚠ Warning: Do not place hot drinks in the cup holder while the vehicle is in motion. There is a risk of scalding if spilled.

⚠ Warning: Use soft cups only. Hard cups or objects can cause personal injury in a collision.

⚠ Do not put open top drinks containers in the cup holders. There is a risk of spillage under heavy braking or steering which can damage electrical components.

Cup holders are located in the front and rear centre consoles.



Front Armrest Storage Box

The front armrest storage box has two USB ports, a 3.5mm auxiliary socket and a 12V accessory socket.



Rear Armrest Storage Box

Including 12V accessory socket.



Door Pockets

All doors have storage pockets.



Coat Hooks

(Optional)

Coat hooks are located in the grab handles, one above each rear passenger door (A).



Umbrella

(Optional)

An umbrella complete with holder is located in the boot storage area.

Accessory Sockets

⚠ Warning: Damage to electrical circuits will result if more than 10 amps is drawn from the accessory socket. Only connect accessories which are designed for use in a motor vehicle.

⚠ Foreign items can get into the socket and cause damage - always place the cover on the accessory socket when not in use.

⚠ Extended use of an accessory socket when vehicle engine is set to OFF will discharge the battery.

Read the manufacturer's instructions and make sure that you do not connect any device which would exceed current rating of the accessory socket.

Accessory sockets are mounted in the front and rear armrest storage boxes, and the right boot side wall and may be used to power any 12 volt vehicle accessory requiring a current of less than 10 amps.

Ashtray and Cigar Lighter

Optional

⚠ Warning: The cigar lighter is heated to 'red heat' when in use. Take care to avoid burns. Do not allow children to play with the cigar lighter.

The cigar lighter can be used in any in cabin accessory socket when the vehicle key is in ignition position 'I' or 'II'.

Push the lighter down until it clicks. The lighter will pop up when ready for use.

⚠ Foreign items can get into the socket and cause damage - always place the lighter back into the accessory socket when not in use.

The ashtray installs into any of the cup holders.

Reading Lamps

Reading lamps are located in the front and rear environments. To operate the lamps (ON or OFF) press the individual switches mounted on the front and rear centre console (A) and (B).

Unless set to OFF or ON they will continue to operate up to six minutes after the ignition is set to OFF.





ASTON MARTIN



ASTON MARTIN



ASTON MARTIN

Controls

Controls Overview	4.2
Instrument Cluster	4.3
Information and Warning Symbols.....	4.6
Centre Stack Controls.....	4.9
Ignition Control.....	4.11
Stalk Controls	4.12
Vehicle Horn.....	4.14
Master Lamp Switch	4.14
Trip Computer	4.15
Tyre Pressure Monitoring.....	4.17
Cruise Control.....	4.19
Ambient Temperature	4.20

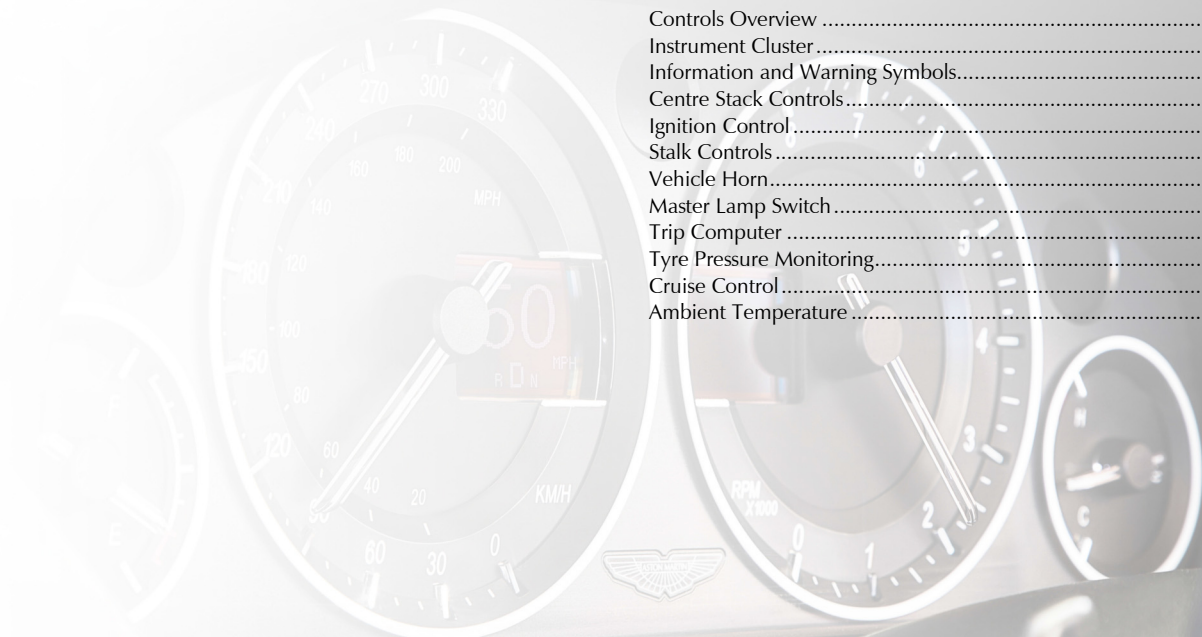



[1] FUEL FLAP RELEASE: Press to open the fuel flap. Close the fuel flap by pressing down on the flap until the lock engages.

Filler Flap Emergency Release: (Refer to 'Fuel Filler Flap Emergency Release', page 5.15)

[2] MASTER LAMP SWITCH: Four position master lamp switch, which controls the vehicle external lamps (OFF, side lamps, main lamps and AUTO) (Refer to 'Master Lamp Switch', page 4.14).

[3] INSTRUMENT CLUSTER: (Refer to 'Instrument Cluster', page 4.3).

[4] CENTRE STACK: (Refer to 'Centre Stack Controls', page 4.9).

[5] JOYSTICK/ENTER: Rotate to navigate through screens and lists. Press to select an item or option (referred to as *ENTER* throughout this chapter)



Instrument Cluster

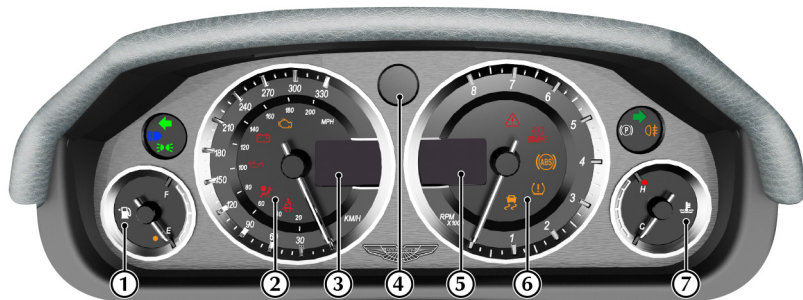

[1] **FUEL GAUGE:** Shows how much fuel is in the fuel tank. Refuel as soon as possible when the low fuel symbol comes ON.

[2] **SPEEDOMETER:** Shows vehicle road speed.

[3] **MESSAGE CENTRE (LEFT):** Shows the following:

- **Vehicle Speed:** Shows the vehicle road speed in a digital format.
- **Gear Range:** Shows the transmission position and current gear selection. Possible transmission positions and gear selection are in bold.

[4] **GEAR POSITION INDICATOR :** Shows the current transmission position when in **Auto Transmission** mode and the current gear selection when in **Touchtronic** mode (Refer to 'Automatic Transmission', page 5.4).

[5] **MESSAGE CENTRE (RIGHT):** Shows the following:

- **Trip Meter (A):** Shows distances travelled since last reset of trip meters T1 and T2. Toggle between T1 and T2 by pressing **T1/T2** (E) for less than three seconds. Press **T1/T2** for more than three seconds to reset the trip meter on show.
- **Sport Mode Status (B):** Shows SPORT when sport mode is ON.
- **Cruise Status (C):** Shows CRUISE when cruise control is ON (Refer to 'Cruise Control', page 4.19).
- **Odometer (D):** Shows the total distance covered by the vehicle.

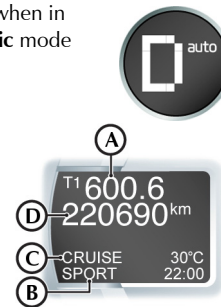

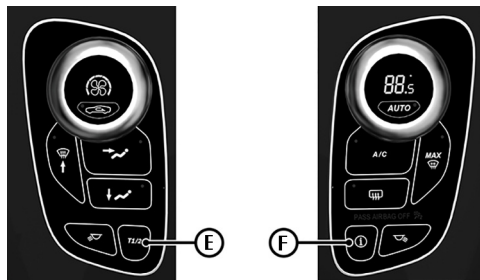

- **Driver Information and Warnings**

Messages show if an unsatisfactory condition is detected. Message priority is shown by a red or amber triangle above the message display.

Red: Potential personal danger or danger of damage to the vehicle.

Amber: Advisory, shows possible degraded vehicle performance.

Warning messages will show when the ignition is ON and will cycle automatically.

View and acknowledge messages at any time by pressing the **READ** button (F).

- **Service Intervals**

TIME FOR REGULAR SERVICE will be shown when a regular vehicle service is due. This message will show at ignition ON (for two minutes) until the regular service has taken place.

- **Trip Computer**

The message centre (right) defaults to the trip computer when there are no messages to show.

[6] TACHOMETER: Shows the engine speed in revolutions per minute x 1000.

[7] ENGINE COOLANT TEMPERATURE GAUGE: Shows the temperature of the engine coolant.

Digital Speedometer Location

The digital speedometer can be displayed in either the left or right message centre depending on preference. All information in the opposing message centre moves to the other message centre side accordingly. To change the digital speedometer location, do the following:

Press **MENU** and navigate to <Car Settings...> **ENTER** <Digital Speedometer...> **ENTER** and select *Left* or *Right* to select the relevant message centre and press **ENTER** to confirm.

Message Centre Clock

The message centre clock is shown in the opposite message centre to the digital speedometer. The clock is shown in either 24 hour or 12 hour display. To change the time format, do the following:

Press **MENU** and navigate to <Car Settings...> **ENTER** <Clock Format> **ENTER** and select 24 or 12 to select the relevant time format for the clock and press **ENTER** to confirm.

Warning Symbols

As the ignition is set to ON, the electronic control units complete a self check. During these checks the following symbols will come ON for five seconds and SYSTEM CHECK will show in the message centre.



Under normal circumstances most warning symbols will go OFF at the end of the individual system check if system checks are satisfactory.

Information and Warning Symbols

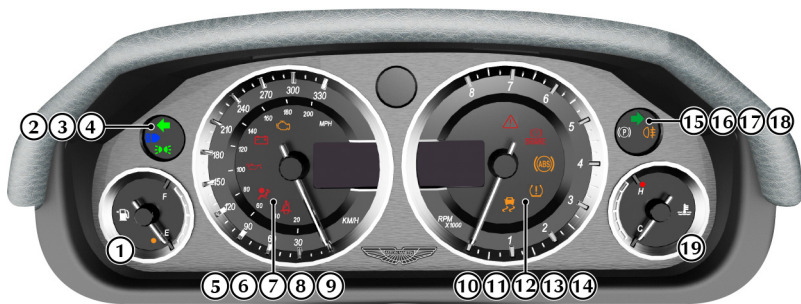

[1] **LOW FUEL WARNING:** Comes ON when only approximately 13 ltr of fuel or 80 km distance is available. At 13 ltr / 80 km and 7 ltr / 40 km an audible 'beep' will sound and the 'estimated distance' message will show (for 20 seconds) in the message centre. The arrow head shows which side of the vehicle the fuel flap is.

[2] **LEFT TURN INDICATORS:** Flashes with the indicator or hazard warning lamps (Ignition ON).

[3] **HEADLAMPS:** Shows that the main beam of the headlamps is in use.

[4] **SIDE LAMPS:** Shows that the side lamps, dip or main beams are ON.

[5] **CHECK ENGINE:** Steady amber shows a fault in the engine management system. Continue driving only if there are no audible, visible or physical signs of degraded engine performance. Consult your Aston Martin Dealer as soon as possible. Flashing amber shows a major fault in the engine management system. Stop immediately. Contact your Aston Martin Dealer.

[6] **IGNITION WARNING:** Comes ON when the ignition is set to ON and goes OFF when the engine is started and battery charging commences. Comes ON if battery charging fails whilst driving.

[7] **OIL PRESSURE WARNING:** Comes ON when the engine oil pressure falls below minimum. Do not continue driving if this symbol stays ON. Contact your Aston Martin Dealer immediately.

Warning: Do not drive the vehicle if the Supplementary Restraint System (SRS) warning symbol stays ON. Have the system checked by an Aston Martin Dealer.

[8] **SUPPLEMENTARY RESTRAINT SYSTEM:** At vehicle key position 'I' and 'II' or on vehicle start up, this symbol comes ON for a few seconds as a readiness sign. If it does not come ON, or if it does not go OFF after a few seconds, or if it comes ON whilst driving, the airbag self diagnostic system has detected a fault.



⚠ Warning: Do not drive the vehicle if the seat belt warning symbol stays ON. Have the system checked by an Aston Martin Dealer.

[9] SEAT BELT WARNING: This warning symbol will come ON and a chime will sound for six seconds if the driver's seat belt is not fastened when the ignition is set to ON. The chime will continue to operate at different vehicle speeds until the seat belt is fastened (market dependant).



[10] DYNAMIC STABILITY CONTROL: When Dynamic Stability Control (DSC) is ON this symbol will flash when the DSC system is operating. If, while DSC is ON, the DSC symbol stays ON or it comes ON whilst driving, the DSC system has detected a fault. A DSC fault message will show in the message centre. Consult your Aston Martin Dealer as soon as possible.



[11] TYRE PRESSURE: If this symbol stays ON or comes ON while driving, a tyre(s) air pressure is below specification.



⚠ Warning: If the ABS warning symbol stays ON, do not drive the vehicle. Have the system checked by an Aston Martin Dealer.

[12] ABS WARNING: If this symbol stays ON or comes ON while driving there is a fault in the ABS control circuits. Continue driving only if there are no audible, visible or physical signs of degraded brake performance. Consult your Aston Martin Dealer as soon as possible if this symbol stays ON.



⚠ Warning: If the brake warning symbol stays ON, after fully releasing the park brake do not drive the vehicle. Have the system checked by an Aston Martin Dealer.

[13] BRAKE WARNING: At ignition ON this symbol comes ON when the park brake is applied and goes OFF when the park brake is fully released. If the symbol stays ON, after fully releasing the park brake, it shows that either the brake fluid level is low or that the brake pads require regular maintenance.



[14] WARNING TRIANGLE: Shows red or amber depending on the warning or information message priority.



[15] ELECTRONIC PARK BRAKE: This symbol shows if there is a fault with the electronic park brake. A warning message will also show in the message centre along with the amber warning triangle. Consult your Aston Martin Dealer as soon as possible.



[16] REAR FOG LAMP: Shows if the rear fog lamps are ON.



[17] RIGHT TURN INDICATORS: Flashes with the indicator or hazard warning lamps (Ignition ON).



[18] IMMOBILISER STATUS: When the immobiliser is on, this symbol flashes continuously (Refer to 'Immobiliser', page 2.14).



[19] HIGH COOLANT TEMPERATURE: Shows when the engine coolant temperature exceeds 120°C.



Engine Oil Level Sensing

! *The electronic engine oil level sensing system does not replace the need for the owner to regularly check their engine oil using the dipstick. Check the engine oil level every fourth fuel tank fill or weekly - which ever is the soonest.*

This vehicle has an electronic engine Oil Level Sensing (OLS) system which records the engine oil level every vehicle start if the vehicle has been left for 4 or more hours, if the vehicle is on level ground, and if it is within a pre-set oil temperature range.

! *Running the engine with engine oil below the minimum mark on the dipstick can cause serious engine damage.*

 *The system may not record an oil level if the engine oil temperature is low or if the time to refuel is not sufficient for a consistent oil level to be recorded.*

For the correct engine oil refer to Fluids and Capacities (Refer to 'Fluids and Capacities', page 13.3).

If the engine oil level is approaching the minimum mark the message OIL LEVEL WARNING CHECK AND TOP UP will show in the message centre along with an amber warning triangle and a chime sound. A code will also be stored in the engine management system. The engine oil level is low and should be checked and filled to the required level engine oil as soon as possible. (Refer to 'Fluid Levels', page 12.8)

The message will clear when the oil level is filled with a least 1 litre to the required level **and** the OLS system has performed a valid check of the oil level.

Low Outside Temperature

! *Warning: Even if the ICE WARNING message does not show, there is no guarantee that at low temperatures the road is free from ice.*

At temperatures below 4°C the message ICE WARNING is shown in the message centre, this shows to the driver that frost or ice is likely to form on road surfaces.

The amber warning triangle  will also come ON.

The message and warning triangle will continue to show until the outside temperature rises to a safer level.

Centre Stack Controls



[1] INFOTAINMENT SCREEN: Opens when the infotainment system is set to ON.

[2] IGNITION CONTROL: Insert the vehicle key for ignition positions '0', '1', 'II' and engine start (Refer to 'Ignition Control', page 4.11).

[3] TRANSMISSION CONTROLS: Park (P), reverse (R), neutral (N) and drive (D) transmission controls (Refer to 'Automatic Transmission', page 5.4).

[4] PHONE AND SATELLITE NAVIGATION: Select phone and satellite navigation functions and move back in the menus.

[5] PASSENGER AIRBAG STATUS: (Market Specific)
Shows the passenger airbag status (Refer to 'Passenger Airbag Deactivation', page 3.19).

[6] CLIMATE CONTROLS: Sets the required vehicle temperatures (Refer to 'Climate Controls', page 7.2).

[7] MAIN MENU AND AUDIO SETTINGS: Select radio, audio sources and menu options.

[8] JOYSTICK/ENTER: Rotate to navigate through screens and list. Press to select an item or option (referred to as **ENTER** throughout this chapter).

[9] ON/OFF/VOLUME: Press to switch the Infotainment system ON and OFF. Rotate to adjust the volume control.

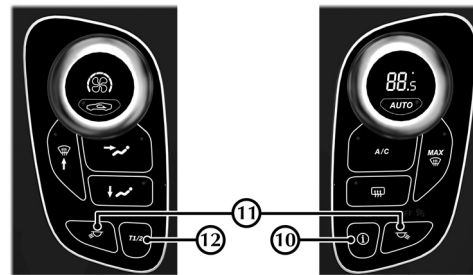

[10] (I) / READ: Press to view and acknowledge messages in the message centre (Refer to 'Instrument Cluster', page 4.3).

[11] READING LAMPS: Driver and passenger reading lamps.

[12] T1/T2: Select between the two trip meters in the message centre (Refer to 'Instrument Cluster', page 4.3).



[13] HAZARD WARNING LAMP: Press to set the hazard warning lamps to ON or OFF.

[14] DYNAMIC STABILITY CONTROL: The Dynamic Stability Control (DSC) system defaults to ON at each ignition ON. Press and hold for four seconds for track mode. Press and hold again for four seconds to set DSC to OFF. Press and release to set DSC ON again (Refer to 'Dynamic Stability Control with Track Mode', page 5.12).

[15] SPORT MODE: Press the sport button once to enter transmission sport mode and press again to exit (Refer to 'Sport Mode', page 5.7).

[16] MULTI-STAGE ADAPTIVE DAMPING: (Optional)

The Adaptive Damping System (ADS) defaults to the last selected damper mode at each ignition ON (Refer to 'Adaptive Damping', page 5.14).

[17] PARK BRAKE: Pull the park brake switch up and release to apply the park brake. To release the park brake the ignition control must be at position 'II', then apply pressure to the foot brake and press down on the park brake switch and release (Refer to 'Park Brake', page 5.10).

[18] REAR FOG LAMPS: Used with the dipped beam when fog or mist is causing restricted visibility. They **must** be set to OFF when visibility clears to reduce glare to the drivers of following vehicles.

[19] PARKING ASSIST: Defaults to OFF at each ignition ON. Park assist comes ON when reverse gear is selected. Press and release to set parking assist to OFF (Refer to 'Parking Assist', page 5.16).

[20] SEAT TEMPERATURE CONTROL: Press and release to select the left or right seat. Turn the dial to set seat temperature (Refer to 'Temperature Controlled Seats', page 3.4).

[21] MASTER VEHICLE LOCK: Press to lock all doors and disable the boot lock switch. Press again to unlock (Refer to 'Master Locks', page 2.8).

[22] REAR A/C: Press and release to set the rear climate from the front controls (Refer to 'Rear Environment', page 7.7).

Ignition Control

To access vehicle functions and to start the engine the vehicle key must be inserted in to the ignition control.



⚠ Warning: Only use the vehicle key in the ignition control. Do not place any objects, including fingers, into the ignition control other than the vehicle key. Objects other than the vehicle key may cause the ignition control to fail.

⚠ The vehicle key must only be inserted into the ignition control with the two indents first, as shown. Attempting to insert the larger end of the key first may damage the ignition control.



Position '0' (Ignition OFF)

Auxiliaries OFF (rear seat entertainment system and infotainment centre consisting of audio, satellite navigation and hands-free phone not available), steering lock ON. Seats can be adjusted.

Gently insert the vehicle key, indents first, into the ignition control. Press in until the key clicks into place, approximately 20 mm (A) then release. The key is docked at this point.

Remove by pulling the vehicle key from the ignition control.

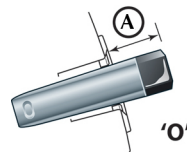

Position '1' (Ignition OFF and Accessories ON)

Auxiliaries OFF (rear seat entertainment system and infotainment centre consisting of audio, satellite navigation and hands-free phone available), steering lock ON. Seats can be adjusted.

- If already in position '0' gently press the key until the infotainment centre and the instrument cluster lamps come ON, a further 10 mm (B) and release for position '1'.
- Or insert the key into the ignition control and move straight to position '1'. Press in until the infotainment centre and the instrument cluster lamps come ON.

Remove by pulling the vehicle key from the ignition control.

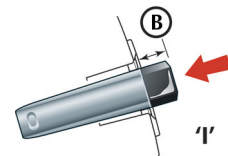

Position 'II' (Ignition ON)

Ignition and all other electrical systems ON, steering lock OFF.

⚠ Do not press the brake pedal down unless intending to start the engine.

 Insert the key to position 'II' by using the flat of a finger, as shown.

- If the key is already in position '0' or '1' gently press the key until it is flush with the ignition control bezel and release.
- Or insert the key into the ignition control and move straight to position 'II'. Gently press the key until it is flush with the ignition control bezel and release.

The Instrument cluster lamps will come ON, the vehicle systems will wake up and the steering lock will release.

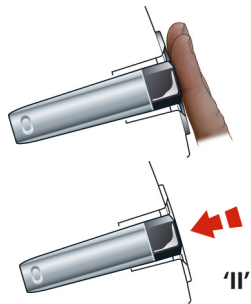

To start the engine from this position fully press the brake pedal down and press the key fully in (Refer to 'Starting the Engine', page 5.3).

To remove the vehicle key from position 'II' press the key fully in **twice** (do not apply the brake pedal) and release. The key will gently return to position '1'. Pull the key from the ignition control. Once in position '1' after 10 seconds the steering lock will engage.

 If the vehicle key is pressed **fully** into the ignition control and released for position 'II', the key must be returned to position '1' to start the engine.

Preventing Unnecessary Battery Drain

If the vehicle key is left in the ignition control (position '0'), some vehicle circuits will stay ON and unnecessary current will be drawn from the battery.

Always remove the vehicle key from the ignition control whenever the ignition is set to OFF.

Stalk Controls

Left Side Stalk

Turn Signals: Press up for a right turn, press down for a left turn. Returns to the centre position on completion of a manoeuvre. Hold against spring pressure to show a lane change.



Main and Dipped Beam: Pull forwards and latch for main beam. Pull forwards again and latch to return to dipped beam. Pull forwards and release without latching, at any time while the vehicle key is in the ignition control, to flash main beam ON and OFF.



Pull forwards and release without latching, when the vehicle key is removed, to start Homesafe (Refer to 'Homesafe', page 2.12).

Trip Computer: Repeated pressing of the trip function button (A) moves through the trip computer displays (Refer to 'Trip Computer', page 4.15).



Right Side Stalk

Windscreen Wiper Control:

[1] : OFF.

[2] : Automatic Wipe.

[3] : Normal Speed Wipe.

[4] : Fast Wipe.

Demand Wipe: Pull the stalk forwards.

 The windscreen wipers will return to their park position if the ignition is set to OFF or the bonnet is unlatched, regardless of the right stalk position.

Speed Sensitive Wipe: If the wipers are at fast wipe, when the vehicle slows down (below 11 km/h) the wipers will go to normal wipe speed.

If the wipers are at normal speed when the vehicle slows down (below 11 km/h) the wipers will go to automatic wipe (position 2).

As soon as the vehicle speeds up (above 15 km/h) the wipers will return to their original setting.



Automatic Rain Sensor Wiper Control:

Automatic rain sensor wiper control increases or decreases the sensitivity in six steps (B). Sixth position (where the arrow is set to the bottom marker) gives the least sensitivity.

Switching from OFF to automatic wiper results in a single wipe to acknowledge that the wiper control is now automatic.

 If the automatic rain sensor wiper control is not functioning correctly, check that the sensor located at the top of the windscreen is clean and clear of debris or dirt.

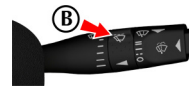

Windscreen Washer Control: Press the button (C) for more than one second to operate the windscreen washers.

Operation continues until the button is released. When released the washers stop immediately but the wipers continue for a few strokes, ending with a pause and then a final wipe.

If used during normal wiper operation, the wipers operate continually irrespective of the washer operation.

Headlamp Washers: Headlamp washers will operate automatically, once per journey (each ignition ON), if the windscreen washers are operated and the headlamps are ON.



Vehicle Horn

To sound the horn press the centre pad of the steering wheel at any of the positions shown (A).



Master Lamp Switch

[1] : All external lamps OFF.

[2] : Side, side marker, rear and registration plate lamps ON.

[3] : With the vehicle key at position 'II' in the ignition control, Headlamps ON, in addition to the side, side marker, rear and registration plate lamps.

[4] : With the vehicle key at position 'II' in the ignition control, if ambient light fades the side, side marker, rear and registration plate lamps and headlamps will switch ON automatically. If ambient light then increases, the side, side marker, rear and registration plate lamps and headlamps automatically go OFF. Automatic lamps are market specific.

 A light sensor at the top of the windscreen monitors ambient light levels for automatic lamps operation. Keep the windscreen clean and make sure that the sensor is not obscured. Obstructing the light in this area may lead to unwanted operation of the automatic lamps.

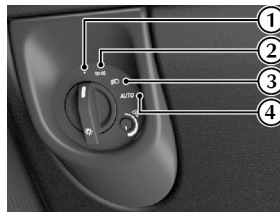

Lamps ON Warning

If the vehicle side lamps are ON, and the driver's door is opened after the vehicle key has been removed from the ignition control, an audible warning will sound for a period of five minutes. To stop the audible warning set the lamps to OFF. The audible warning will also stop when the driver's door is shut - the lamps will stay ON.

Day Time Running Lamps

(Denmark, Norway and Sweden only)

The dipped beams and side lamps are permanently ON.

Trip Computer

Instrument Brightness

During darker hours, a twilight sensor, located at the top of the windscreen, automatically reduces the brightness of the instrument cluster to a preset level.

 During the daylight hours the level of instrument brightness defaults to maximum brightness. If the twilight sensor is covered then the level of brightness will stay low as if in night time mode.

 If the master lamp switch is OFF then the instrument brightness will always be in daylight mode, unless altered manually.

Use the rotary control (B) to adjust the brightness. Push the rotary control in and release to enable the control. Push back in and release to lock the control.



Press the **TRIP** button (A) for less than three seconds to cycle through the trip computer functions one at a time. Trip computer information is viewed in the message centre.

 If an information message shows, after reading and acting on the information provided press the **READ** button (B) to return to the trip display.



Range: Shows the estimated travel distance with fuel available (no reset). When there is no available fuel, then '-----' is shown.



Average Fuel and Instantaneous Fuel:

Shows the fuel consumption over the last three seconds of travel (no reset).

Also shows the average fuel consumption since the last reset. This is indicated by the \emptyset average symbol.



Press the **TRIP** button (A) for four seconds to reset the average fuel consumption. Press the **TRIP** button (A) for five seconds or more to reset both the average fuel consumption and average speed. **INFO CENTER IS RESET** is then shown in the message centre. This message disappears after a few seconds. If not, press the **READ** button to acknowledge the message.

Average Speed: Shows the average speed since last reset. This is indicated by the \emptyset average symbol.

Press the **TRIP** button (A) for approximately four seconds to reset. Press the **TRIP** button (A) for five seconds or more to reset both the average speed and average fuel consumption.

INFO CENTER IS RESET is then shown in the message centre. This message disappears after a few seconds. If not, press the **READ** button to acknowledge the message.

Tyre Pressure Monitor: Shows the current tyre pressure for all tyres (Refer to 'Tyre Pressure Monitoring', page 4.17).



Display Units

Distance

To change the display units to show miles or kilometres:

From the **MAIN MENU**, select **<SYSTEM SETTINGS> ENTER <Units> ENTER <Distance units>**.

Select the *Miles* or *Kilometres* check box and press **ENTER** to confirm.

Temperature

To change the display units to show Celsius (°C) or Fahrenheit (°F):

From the **MAIN MENU**, select **<SYSTEM SETTINGS> ENTER <Units> ENTER <Temperature units>**.

Select the **°C** or **°F** check box and press **ENTER**.

Power Meter

To change the units shown on the power meter:

Power

From the **MAIN MENU**, select **<SYSTEM SETTINGS> ENTER <Units> ENTER <Power Units>**.

Select the *BHP*, *PS* or *Kw* check box and press **ENTER** to confirm.

Torque

From the **MAIN MENU**, select **<SYSTEM SETTINGS> ENTER <Units> ENTER <Torque Units>**.

Select the *LbFt* or *Nm* check box and press **ENTER** to confirm.

 When the units are changed, the ranges on the power meter will also update to suit the new units.

Tyre Pressure Monitoring

⚠ Warning: Driving on a significantly under-inflated tyre causes the tyre to overheat and can lead to tyre failure. Over-inflation and under-inflation also reduces fuel efficiency and tyre tread life, and may affect the vehicle's handling and stopping ability.

Each tyre should be checked at least once every two weeks when cold, and inflated to the pressure recommended by the vehicle manufacturer on the Tyre and Loading Information placard or the tyre pressure label. If your vehicle has tyres of a different size than the size indicated on the Tyre and Loading Information placard or the tyre pressure label, you should determine the proper tyre pressure for those tyres.

Tyre Status Screen

A tyre status screen can also be viewed in the infotainment system which gives a larger display showing tyre pressure and tyre temperature. The tyre status screen will also show the same warnings as the TPMS system in the message centre. However, the tyre status screen will not automatically be displayed in the event of a tyre warning. (Refer to 'Tyre Status', page 6.6)

Tyre Pressure Indicator

As an added safety feature, your vehicle has been equipped with a Tyre Pressure Monitoring System (TPMS). If an over or under-inflated tyre is detected by the system, the TPMS indicator (A) is solidly illuminated. At the same time, the vehicle message centre will display the text **CHECK TYRES**. Once the message has been acknowledged an image of the vehicle will be displayed in the message centre showing which tyre(s) have low or high air pressure and the current tyre pressure. When the tyre pressure indicator comes ON, stop and check your tyres as soon as possible, and inflate or deflate them to the correct pressure.

📖 *The TPMS is not a substitute for correct tyre maintenance, and it is the driver's responsibility to maintain correct tyre pressures, even if under-inflation has not reached the level to set the TPMS tyre pressure indicator symbol to ON.*

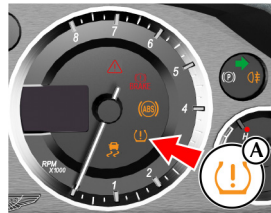

Malfunction Indicator

Your vehicle has also been equipped with a TPMS malfunction indicator to show when the system is not operating correctly. The TPMS malfunction indicator is combined with the tyre pressure indicator.

When the malfunction indicator is illuminated, the system may not be able to detect or signal low tyre pressure as intended. TPMS malfunctions may occur for a variety of reasons, including the installation of incompatible replacement or alternate tyres or wheels on the vehicle that prevent the TPMS from functioning properly.

Always check the TPMS malfunction indicator after replacing one or more tyres or wheels on the vehicle to make sure that the replacement or alternate tyres and wheels allow the TPMS to continue to function correctly.

When the system detects a malfunction, the indicator will flash for approximately 80 seconds and then stay ON. At the same time the vehicle message centre will display the text **TYRE SYSTEM FAULT**. Once the message has been acknowledged an image of the vehicle will be displayed in the message centre showing which tyre(s) have a fault. This sequence will continue upon subsequent vehicle start-ups as long as the malfunction exists.

Operation

⚠ When a tyre pressure warning is detected reduce the vehicle speed to an appropriate safe level and stop at the first safe and convenient place to inspect the tyre(s).

At each ignition ON there is a short delay before tyre pressures are received from the wheel and tyre transmitters, and being shown in the message centre and infotainment screen (if selected).

If the TPMS indicator symbol comes ON while driving, reduce speed to 30mph / 48 km/h and stop in a safe place as soon as possible.

Check the status of the tyre(s) in the message centre:

Warning One

TPMS Indicator Symbol

Constantly on.

Message Centre

CHECK TYRES (for four seconds) followed by an image that shows which tyre(s) is affected and the current tyre pressures.

Fault

Tyre pressure below or above specification.

Action

Check the tyre pressure of the affected tyre(s). Set the tyre pressure to the manufacturer's recommended pressure, as shown on the tyre label located on the edge of the driver's door or the B-Pillar.



Warning Two

TPMS Indicator Symbol

Flashing for 80 seconds then constantly on.

Message Centre

TYRE SYSTEM FAULT (for four seconds) followed by an image that shows the current tyre pressures and which transmitter is at fault.

Fault

System failure or tyre transmitter fault.

Possible Cause

- The TPMS sensors have become defective.
- Wheels and tyres have been installed which do not have TPMS sensors.
- An unapproved accessory is interfering with the TPMS.
- A general fault has been detected in the TPMS.

Action

Continue at a reduced speed of 30mph / 48 km/h maximum. Check the control unit and the tyre transmitters at the earliest opportunity. Consult your Aston Martin Dealer.



Cruise Control

Cruise control can be used to maintain a selected vehicle speed (between 30 - 250 km/h) without having to use the accelerator.



[1] **RES:** Resume the set speed retained in memory.

[2] **SET:** Sets cruise control to ON and sets the speed. Press either + or - to increase or decrease the set speed.

[3] **CAN:** Cancels cruise control but keeps the set speed in memory.

Operation

⚠ Warning: Only use cruise control when conditions are favourable, for example, straight, dry, open roads with light traffic.

Press and hold the **SET** (+ or -) button to switch cruise control ON. When cruise control mode is ON, 'CRUISE' will show in the message centre.

When travelling at the desired speed, which must be above 30 km/h, press the **SET** (+ or -) button. Cruise control will then engage and maintain that speed without the need to use the accelerator pedal. 'CRUISE - SET' will show in the message centre.

📖 Under certain conditions cruise control will automatically set to OFF (Refer to 'Cruise Control Automatic OFF', page 4.20).

📖 Cruise control will automatically disengage when the brake pedal is pressed or when the vehicle speed falls below 30 km/h.

Changing the Set Speed

There are three ways to change the set speed:

- Accelerate or decelerate to the desired speed then press the **SET** (+ or -) button.
- Accelerate or decelerate to the desired speed by pressing and holding the **SET** (+ or -) button until the desired speed is obtained, then release.
- Accelerate or decelerate to the desired speed in steps of 2 km/h by briefly pressing and releasing the **SET** (+ or -) button until the desired speed is obtained.

Resuming the Set Speed

! *RES should only be used if the driver is aware of the set speed and intends to return to it.*

! *It is not recommended to resume set speed when a low gear is selected as excessive engine speeds will occur.*

 *Cruise control will not resume at speeds below 30 km/h. RES will not operate if the ignition has been set to OFF.*

If the vehicle is accelerated above the set speed, then the set speed will be resumed when the accelerator pedal is released.

If the **CAN** button is pressed, or the brake pedal is pressed, cruise control will disengage but the set speed memory will be kept. Press the **RES** button and the vehicle will return to the set speed.

Cruise Control Automatic OFF

Cruise control will automatically set to OFF and clear the memory when:

- The ignition is set to OFF.
- The **CAN** button is pressed and held for a few seconds.
- A fault occurs. The cruise control system will set to OFF and cannot be used until the fault is cleared.

Cruise control will automatically set to OFF but the set speed will stay in the memory when:

- The **CAN** button is pressed once briefly.
- The park brake is applied.
- The brake pedal is pressed.
- Vehicle speed falls below 30 km/h.
- If DSC is active.
- Neutral, Park or Reverse gear positions are selected.

Ambient Temperature

The ambient temperature (outside temperature) is shown in the top right corner of the Infotainment centre display.

 *If the vehicle has been travelling and then is stopped in a shaded or enclosed area the ambient temperature may rise, this is due to the heat from the engine bay. The ambient temperature display will show the true ambient temperature once the vehicle is moving again or the engine bay cools down.*

 *If required the display units can be changed from °C to °F or °F to °C (Refer to 'Display Units', page 4.16).*

Driving

Driving Safety.....	5.2	Footbrake.....	5.8
Driving Techniques	5.2	Anti-lock Braking System	5.9
Starting the Engine	5.3	Park Brake.....	5.10
Automatic Transmission.....	5.4	Dynamic Stability Control with Track Mode.....	5.12
PRND Buttons.....	5.5	Adaptive Damping	5.14
Touchtronic Controls.....	5.6	Fuel Filling.....	5.14
Sport Mode.....	5.7	Catalytic Converters	5.15
Fault Conditions.....	5.8	Parking Assist.....	5.16
		Reversing Camera	5.17



Driving Safety

- Always wear your seat belt.
- Never drive under the influence of alcohol or drugs.
- Always obey all speed and traffic laws and regulations. Never drive faster than the posted speed limit or than conditions allow.
- Be particularly careful driving on slippery or wet surfaces.
- This vehicle is a high performance vehicle and has handling characteristics you may not be accustomed to. Familiarise yourself with the vehicle and always drive prudently, being aware of your own limitations and the limitations of the vehicle. As with other vehicles of this type, failure to operate the vehicle correctly can result in accident and injury.
- Follow the maintenance schedule approved in this guide.
- Never allow the vehicle to be driven by inexperienced drivers.

 *Make sure that you are wearing appropriate footwear to efficiently operate the control pedals. Make sure that pedal movement is not restricted by floor mats or other objects trapped beneath pedals.*

Driving Techniques

Procedures for driving this vehicle may be unfamiliar to many new owners. To make sure that you have a safe and enjoyable entry into this new phase of Aston Martin motoring, please take time to safely acquire the necessary new driving skills. Practise in safe, lower speed conditions before investigating the high performance potential of the vehicle.

Performance driving courses are available to enable you to fully understand the control functions of your vehicle and also the basic principles of performance driving. Contact your Aston Martin Dealer for further information.

Running-In

This vehicle is fully hot tested during manufacture and no special running-in procedures are necessary. Nevertheless it is recommended to limit engine loads (e.g. by accelerating gently and by using lower gears on steep hills or when negotiating tight turns) during the first 1500 km/900miles.

Track Days

Before using this vehicle on track days contact your Aston Martin Dealer for vehicle set up, service parts and recommendations.

Wet Conditions

When driving in wet conditions, water can build up under your tyres so that they ride on a layer of water. This is called aquaplaning or hydroplaning. When this happens, you have little or no control. Aquaplaning is more prone to happening at higher road speeds if there is a lot of water on the road and particularly if the tyres are also under inflated or approaching minimum tread depth.

It is important to take bends or curves at a safe, reasonable speed, particularly when driving on wet or slippery road surfaces.

Slow down when it is raining.

Starting the Engine

Driving Through Deep Water

If in any doubt whether to drive through deep water, always take the side of caution to avoid potentially costly damage to the vehicle's engine or other essential systems.

! *Never drive in water deeper than the lower edge of the front bumper. Water can be splashed up into the engine air intakes located in the front upper grille and cause extensive damage to the engine or the vehicle may stall. Always proceed with extreme caution, especially when the depth is not known.*

When driving through water, traction or brake capability may be limited. Once through the water, always dry the brakes by driving slowly while applying light pressure on the brake pedal.

 Waves caused by other vehicles or natural causes can also splash water in the engine air intakes.

! *Warning: Only use the vehicle key in the ignition control. Do not place any objects, including fingers, into the ignition control other than the vehicle key. Objects other than the vehicle key may cause the ignition control unit to fail.*

! *In extreme low temperatures (-20°C and below) do not allow the engine to 'rev' above 4000 rpm, while at standstill or when moving off, until the coolant temperature gauge reaches normal operating temperature. Revving the engine before fully warmed up may cause severe engine and transaxle damage.*

! *Do not press the vehicle key while driving. If the key is pressed in and released the engine will stop. If the key is removed from the ignition control while driving the engine will stop but the steering lock will not engage until the vehicle has come to a complete stop.*

! *The vehicle key must only be inserted into the ignition control with the two indents first, as shown. Attempting to insert the larger end of the key first may damage the ignition control.*



Ignition Sequence

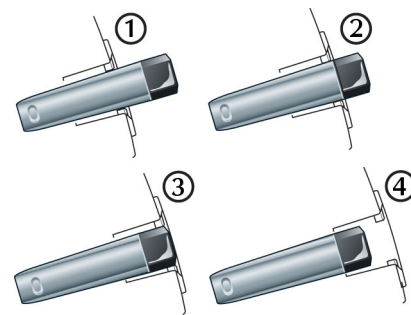

[1] : Position '0' (Ignition OFF)

[2] : Position 'I' (Ignition OFF and Accessories ON)

[3] : Position 'II' (Ignition ON)

[4] : Engine start

Engine Start

Check that the park brake is applied.

Fully press the brake pedal down.

Insert the vehicle key into the ignition control and press the key fully in and release.

The vehicle key will sit flush with the ignition control bezel while the engine is running. The ignition control will show a white light when the engine is running, and then fade out.

 When starting the engine the vehicle system will take a short time (approximately one second) to complete a system check and release the steering lock before allowing the engine to crank.

If the engine fails to start, remove the key, then press the key fully in again **without the brake pedal pressed down** and release. The key will gently return to position '1'. Start the engine start procedure again.

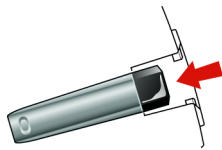

Starting From Cold

The Engine Control Module (ECM) automatically compensates for cold or warm start conditions and makes appropriate adjustments to the fuel and air mixture and ignition timing.

Stopping the Engine

Press the vehicle key fully in and release. The engine will stop as the key returns to position '1'. Withdraw the vehicle key from the ignition control.

Maximum Engine Speed

The maximum safe engine speed is 7,000 rpm. If this speed is exceeded, fuel supply to the engine is reduced. As the engine speed reduces back to a safe level, fuel supply is progressively restored.



Automatic Transmission

The automatic transmission has two drive modes.

Auto Transmission Mode

In auto transmission mode, gearshifts are made using the Park, Reverse, Neutral and Drive (PRND) buttons mounted on the centre stack. While driving forward, gearshifts are made automatically according to various driving parameters, i.e. road speed, current selected gear and accelerator demands. When the vehicle is stationary, the transmission will select first gear, ready to move off immediately when the accelerator is pressed.

While in auto transmission mode, move to touchtronic mode at any time by pulling back on either the upshift or downshift paddles, mounted behind the steering wheel. As a paddle is pulled back a gearshift will occur, which will be an upshift or downshift according to which paddle is pulled.

Kick-Down

In auto transmission mode, kick-down is used in circumstances where rapid acceleration is required, i.e. when overtaking. Kick-down operates when the accelerator pedal is quickly and fully depressed, causing the transmission to change down to the lowest gear possible to achieve maximum acceleration. The gear engaged depends on the road speed at the time of kick-down.

PRND Buttons

Touchtronic Mode

In touchtronic mode, forward gears and Neutral are selected by using the paddles located behind the steering wheel. Reverse and Park are selected by using the PRND buttons.

While in touchtronic mode, move to auto transmission mode at any time by pressing the **D** button, or by pulling and holding the upshift (+) paddle until drive mode is selected.

Select Neutral by pulling on both the upshift and downshift paddles at the same time.

 *Neutral can also be selected by pressing the **N** button.*



[1] PARK: Press and release to select park once the vehicle is stationary. The transmission will mechanically lock. If the vehicle key is moved to position '0' or removed from the ignition control while the vehicle is at a standstill, the transmission will automatically select park.

 **Always make sure that the park brake is ON.**

 *It is not possible to select Park above 2 km/h.*

[2] REVERSE: When stationary and with the footbrake applied, press and release to select Reverse. When reverse is selected, **R** will show red in the Gear Position Indicator Display (GPID) (B) and a warning will be heard.

[3] NEUTRAL: When stationary and with the footbrake applied, press and release to select Neutral.

[4] DRIVE: When stationary and with the footbrake applied, press and release to select forward gears.

 *If the brake pedal is not pressed the message centre will show **PRESS BRAKE PEDAL** and a warning will be heard.*

The left message centre (A) shows the current gear selection R, D1, D2, etc., while the Gear Position Indicator Display (GPID) (B) shows D (Drive), R (Reverse) or P (Park) according to current gear position. While in auto drive mode the GPID will show 'auto'.

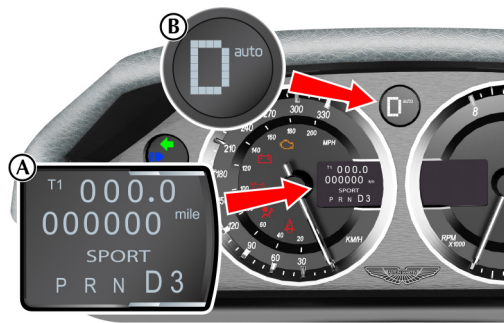

Vehicle Rocking Motion

If the vehicle speed is less than 4 km/h, reverse may be selected from drive, without pressing the brake pedal, to create a vehicle 'rocking' motion i.e. to enable vehicle movement out of mud, snow, etc. If 4 km/h is exceeded then the transmission will automatically select Neutral.

Touchtronic Controls

Forward gearshifts are selected by pulling back and releasing the gearshift paddles mounted on the steering column. Neutral is selected by pulling back both paddles together and releasing.

Park and Reverse are selected by using the centre stack mounted PRND buttons.

[1] : Downshift paddle.

[2] : Upshift paddle.

 Neutral can also be selected by pressing **N**.

From Park, Reverse or Neutral, and with the footbrake applied, pull back on either the upshift or downshift paddle to enter touchtronic mode. As the vehicle speed increases and decreases, make upshifts and downshifts by pulling and releasing the upshift or downshift paddle.



If no gearshift has been requested by pulling back on a paddle, upshifts and downshifts will occur automatically if the engine speed rises or lowers to its maximum or minimum operating limits. This does not occur if the transmission is in sport mode (Refer to 'Sport Mode', page 5.7).

If driving in a high gear, pull and hold the downshift paddle to select the lowest available gear. For example, if in sixth gear then second gear is selected.

When stationary, select Neutral by pulling back on both paddles simultaneously. When selecting Neutral from Park, the brake pedal must be depressed.

When in touchtronic mode, pull back on the upshift paddle for more than two seconds to move to auto drive mode.

The message centre shows the actual gear currently selected R, D1, D2, etc. The GPID also shows the current gear selected but may show the target gear when a gearshift is in progress (either 1, 2, 3, 4, 5, 6, 7, 8, R or P). The GPID will show 'touch'.



Sport Mode

Gear Shift Indicator

The message centre also shows the current gear selected with an up or down arrow and shows the next gear when it needs selecting to obtain better fuel economy. For example, when in third gear and fourth gear needs selecting 3 ^ 4 is shown in the message centre.

Sport mode can be selected while in auto drive or touchtronic modes. Press and release the Sport button (A) to enter or exit sport mode. The Sport button LED will come ON and SPORT will show in the message centre when sport mode is ON.

Auto Mode: Upshifts and downshifts occur at higher engine speeds to provide a sportier drive.



Touchtronic Mode: Automatic upshifts are prevented, the upshift paddle must be pulled back and released to make an upshift (downshifts will occur automatically if the engine speed lowers to its minimum operating limits).

To maintain speed and smoothness while driving in touchtronic sport mode, the current gear, shown in the GPID, will flash red at the optimum time to make an upshift.



Automatic upshift from first to second gear occurs in auto mode and touchtronic mode.

Keep Sport Mode

When the ignition is set to OFF, sport mode will reset to OFF. This is the default setting.

If you would like sport mode to be ON when the ignition is set to ON, complete the following procedure: Press **MENU**. Navigate to <SYSTEM SETTINGS> and press **ENTER**. Navigate to <Keep sport mode> and press **ENTER** to set <Keep sport mode> to ON.

Fault Conditions

Limp-home Mode

If a fault is detected the vehicle will go into one of three limp home modes:

Electrical: GEARBOX FAULT REDUCED FUNCTION will show in the message centre. Touchtronic and sport modes will be disabled. Gearshifts will still be possible but shift quality will be degraded.

 In certain circumstances forward drive will be restricted to a fixed gear.

Contact your Aston Martin Dealer.

Reduced Engine Performance: REDUCED ENGINE PERFORMANCE will show in the message centre. Engine performance will be restricted. Contact your Aston Martin Dealer.

Mechanical: LIMPHOME NO GEAR CHANGE POSSIBLE will show in the message centre and a warning sound will be heard. If travelling forwards in auto drive or touchtronic mode the vehicle will go into sixth gear.

 **Do not attempt to change gear position while in mechanical limp home mode. If a gearshift request is detected at a speed below 20 km/h the engine will stop and the parklock will come ON.**

 **At a speed above 20 km/h the request and any other transmission request will be rejected and the vehicle will continue in third or fifth gear.**

If entering mechanical limp home mode in any position other than auto drive or touchtronic mode the parklock will come ON. Contact your Aston Martin Dealer.

Footbrake

The footbrake operates through a vacuum boosted, dual (diagonal split) circuit, hydraulic system incorporating an Anti-lock Brake System (ABS).

 **Warning: In the event of a brake failure bring the vehicle to a halt as soon as it is safe to do so. Do not continue to drive.**

 **If vacuum boost fails or one circuit fails the footbrake will still operate but with greater pedal pressure, increased pedal travel and longer stopping distances.**

 **After a long drive over salted or gritted roads or if driving in heavy rain, through water or a vehicle wash, the braking action may be delayed and increased braking pressure may be required.**

 Vacuum boost is only available while the engine is running.

 The high performance brake system used on this vehicle is designed to provide optimal braking under all operating conditions. However, an inherent characteristic of this braking system is some brake noise. Certain combinations of speed, braking forces and ambient conditions may also cause the brakes to squeal.

Brake Throttle Override

If the throttle and brake pedals are both pressed at the same time for over 3 seconds, the engine will restrict available torque. Normal functionality will return when the throttle pedal is pressed without the brake pedal.

Brake Warnings

⚠ Warning: If the brake warning symbol comes ON, you should immediately be prepared for possible increased stopping distances and possible partial failure of the braking system.

While driving, if the brake warning symbol  comes ON, it shows either that:

- The park brake is not fully released.
- The brake pads require regular maintenance.
- The brake fluid level has fallen below an acceptable level.
- The Electronic Brake Distribution (EBD) system has stopped working.

 A warning message will show in the message centre.

Stop as soon as possible in a safe and convenient place. Apply the footbrake and make sure that the park brake is fully released. If the park brake is fully released and the warning symbol stays ON, **do not drive** the vehicle. Contact the nearest Aston Martin Dealer. It is essential that the brake system is checked immediately, preferably by an Aston Martin Dealer.

Anti-lock Braking System

The Anti-lock Braking System (ABS) helps prevent the road wheels from locking and skidding during emergency braking. This also assists the driver in maintaining steering and directional stability.

If, in an emergency braking situation, the braking force applied begins to exceed the tyre to road adhesion, the ABS operates to prevent the road wheels locking. When this happens a pulsating effect is felt through the brake pedal. This is a normal ABS effect.

Safety

In all cases it is always the drivers responsibility to drive safely according to the law and with due regard to prevailing conditions. The fact that a vehicle is equipped with ABS must never let the driver to be tempted into taking risks which could affect his or her safety or that of other road users.

The addition of ABS cannot overcome the consequences of trying to stop in too short a distance, cornering at too high a speed, or the risk of aquaplaning (where the tyres are prevented from contacting the road surface by a layer of water).

The driver should always take road conditions into account. A slippery road surface always requires more braking distance for a given speed, even with ABS. Possible extensions of stopping distance compared to locked wheels may occur during ABS operation on slushy snow, gravel, sand or certain heavily corrugated or ridged warning sections of road surfaces.

If any braking system malfunction occurs, immediately have the braking and ABS systems checked by your Aston Martin Dealer.

ABS Warning

⚠ Warning: If the ABS warning symbol comes ON, you should be aware that wheels could lock during extreme braking or when braking on slippery surfaces.

ABS is monitored for correct operation while the ignition is ON. If a fault is detected, the ABS warning symbol  will come ON and the ABS will be partly or fully OFF. Normal braking will continue to function without ABS.

In the event of an ABS fault, consult your Aston Martin Dealer immediately.

Park Brake

Apply and Release the Park Brake

⚠ Warning: Do not rely on the park brake to hold the vehicle stationary if the brake system warning symbol is ON or flashing. Contact your Aston Martin Dealer.

With the vehicle stationary, pull the park brake switch (A) up and release. The red park brake warning symbol in the instrument cluster

will come ON  BRAKE (if the ignition is ON) when the park brake is fully applied. The stop lamps will not come ON.

⚠ The park brake operates on the rear wheels of the vehicle. Secure parking of the vehicle is dependent on being on a hard and stable surface.

To release the park brake the ignition control must be at position 'II'. First apply pressure to the foot brake then press down on the park brake switch and release.



Drive Away Release

! *Do not exit the vehicle with the engine operating and the transmission in D (drive) or R (reverse). Always select P (park) before exiting the vehicle. If the transmission is left in D or R the vehicle could overcome the park brake and start to move.*

When parked with the park brake applied, select a forward or reverse gear, press the throttle pedal and the park brake will release as the vehicle moves forwards or backwards.

The park brake will not release when moving from a standstill if a vehicle door or the boot is open - in this case the park brake must be released with the park brake switch.

Park Brake Operation While Moving

! *Driving the vehicle with the park brake applied or repeated use of the park brake to slow the vehicle can cause serious damage to the brake system.*

In an emergency, with the vehicle travelling at more than 6 km/h, pull up on the park brake lever and hold to give a gradual reduction in speed. The brake warning symbol will come ON, a warning sound will be heard and CAUTION PARK BRAKE APPLIED will show in the message centre.

Release the switch to cancel the park brake application.

Park Brake Faults

Low Battery Voltage

If the battery voltage is too low, the park brake cannot be put ON or OFF. Connect an auxiliary battery if the battery voltage is too low.

System Faults

If a fault in the system is detected, PARK BRAKE FAULT or CANNOT APPLY PARK BRAKE will show in the message centre. Contact your nearest Aston Martin Dealer.

If the battery has been discharged or disconnected, APPLY FOOT AND PARK BRAKE will show in the message centre when the ignition is next ON. Press the foot brake down and pull the park brake lever up to put the park brake ON, this will reset the park brake system.

Dynamic Stability Control with Track Mode

⚠ Warning: *It is the driver's responsibility to drive safely according to the law and with due regard to prevailing conditions.*

⚠ Warning: *Dynamic Stability Control (DSC) must never let the driver be tempted into taking risks which could affect his or her safety or that of other road users. DSC cannot overcome consequences of applying too much engine power for prevailing conditions.*

Dynamic Stability Control (DSC) is a system designed to enhance driving safety by improving the vehicle handling when the tyres are at the limits of their grip capabilities. This is achieved through the reduction of engine torque and strategic application of the brakes at individual wheels.

Driver Interface and Control

⚠ *If repair or replacement of the steering or other surrounding equipment is necessary, always refer to your Aston Martin Dealer. There is a sensor in the steering system which detects steering angle. If the centre position of the steering deviates, the DSC system may not operate correctly.*

⚠ *The DSC system may not operate correctly when using tyre chains or a temporary spare tyre.*

⚠ *Use tyres of the same manufacturer, brand, type, tread pattern and correct size specified for this vehicle on all four road wheels. Do not mix new and worn tyres on the same axle.*

DSC has three modes of operation:

ON: The DSC system sets to ON each time the engine is started. DSC is controlling engine torque and applying strategic application of the brakes at individual wheels.

While the DSC system operates to correct the vehicle stability the



DSC symbol on the instrument cluster, will flash.

TRACK MODE: Press and hold the DSC button (A) for four seconds and release. DSC TRACK MODE SELECTED will show in the message centre. This raises the thresholds at which the DSC system operates. While the DSC system operates to correct the vehicle stability the DSC symbol will flash.



OFF: From Track mode, press and hold the DSC button for four seconds and release to set the DSC to OFF. DSC OFF can not be selected from DSC ON. DSC FUNCTION OFF will show in the message centre. DSC is no longer controlling engine torque and applying strategic application of the brakes at individual wheels.

At any time while in track or off mode, press and release the DSC button to start DSC.

 In Track mode or OFF, the DSC button LED will come ON and the amber warning triangle will be shown in the instrument cluster.

Fault Signs

A malfunction in the DSC control system will be shown by the following:

- The DSC symbol in the instrument cluster will come ON.
- A warning message will show in the message centre depending on the fault detected.

Traction Control

 **Warning: It is always the drivers responsibility to drive safely according to the law and with due regard to prevailing conditions.**

 **Warning: Traction control must never let the driver be tempted into taking risks which could affect his or her safety or that of other road users.**

 **Warning: Traction control cannot overcome consequences of applying too much engine power for prevailing conditions.**

Traction control is a function of DSC, and is operated in association with the DSC system. Traction control prevents excessive wheel spin at standing starts, or during acceleration. Wheel spin is usually caused by excessive use of the accelerator pedal, or slippery, loose or bumpy road surfaces.

To prevent excessive wheel spin and maintain vehicle stability in such situations the traction control system will:

- Brake either of the driven wheels when they start to slip
- Adapt the engine torque to a level corresponding to the traction available on the road surface.

 These symptoms are normal and will clear as wheel spin is eliminated and normal engine power is restored.

 If cruise control is on it will automatically go OFF when DSC is operating.

During operation, the DSC warning symbol will flash. The driver may experience a loss in power or temporary 'misfire' as engine power is reduced.

If traction control cuts in when driving on extended icy or slippery surfaces, reduce engine power as necessary until the DSC warning symbol goes OFF.

Traction control is always ON when DSC is ON.

Adaptive Damping

The Adaptive Damping System (ADS) is continuously ON, adjusting the damping characteristics at all four corners, according to vehicle body movement and monitored driver inputs. Sensors on the vehicle constantly measure the vehicle body movement and driver inputs – braking, steering, vehicle speed and throttle displacement. This information is then supplied to the ADS control unit which calculates the optimal damper characteristic at each corner at any given moment.

 ADS is independent of the Dynamic Stability Control (DSC) system.

Multi-Stage Adaptive Damping

(Optional)

ADS has three modes of operation:

Normal Mode: This mode gives damping characteristics for everyday driving (button LED OFF).

Sport Mode: Press the ADS button (A) to start sport mode, which gives damping characteristics for a firmer ride.

To move back to normal mode (button LED OFF), press and release the ADS button. A message on the console confirms the damper mode has been switched.

Track Mode: Press and hold the ADS button (A) for more than 1 second to start track mode (button LED FLASHES) which provides damping characteristics suitable for track driving.

To move back to normal mode (button LED OFF), press and hold the ADS button for more than 1 second. To move back to sport mode (button LED ON), press and release the ADS button. A message on the console confirms the damper mode has been switched.

 When the ignition is switched off, the system latches to the last selected damper mode upon restarting.



Fuel Filling

 The fuel tank filler neck has a restricted opening which will only accept the fuel supply nozzle of unleaded fuel pumps.

Open the fuel flap by pressing the fuel flap release button (A) located in the driver's footwell to open the capless fuel filler flap (B). If the filler flap will not open when the release button is pressed, use the fuel filler flap emergency release.

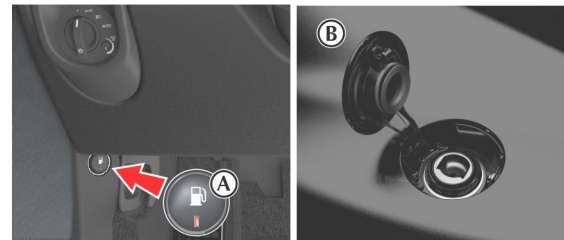

The fuel system will not let the fuel tank overfill but there will be times when the fuel nozzle will shut OFF prematurely. If this happens only try to fill the fuel tank one more time, continued attempts will result in fuel spillage. Wait 10 seconds before removing the refuelling nozzle.

Emergency Fuel Fill

An emergency fuel fill funnel is located in the boot tool kit. It can be used to fill the fuel tank from a fuel can.

Fuel Filler Bowl

The fuel filler bowl has a pipe to let the water drain from the bowl. During fuel filling, check and make sure that any debris which may block the pipe is removed.

Fuel Filler Flap Emergency Release

Remove the left side boot trim panel (C) to access the manual fuel filler flap release. Push the lever (D) towards the front of the vehicle to open the filler flap.

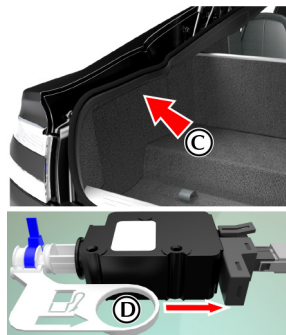

Fuel Cut-OFF

In the event of a vehicle accident the vehicle electronics will enter crash mode. Power to the fuel pumps will stop, thereby reducing fire risk.

Engine Oil Level

⚠ It is important to check the engine oil level regularly. Running the engine with engine oil below the lower mark or above the upper mark can cause serious engine damage.

Check the engine oil level every fourth fuel tank fill or weekly - whichever is the sooner.

Catalytic Converters

⚠ Warning: Do not park over dry grass, leaves or other combustible material. Significant fire risk exists because of residual heat in the catalytic converters.

⚠ Warning: Do not drive through deep water. Rapid cooling of catalysts may cause them to break up.

Catalytic converters convert harmful exhaust gasses into less noxious substances and so reduce environmental pollution. They operate at high temperatures and continue to radiate a considerable amount of heat after the ignition has been set to OFF.

Parking Assist

⚠ Warning: Parking assist does not replace need for total vigilance and caution when parking or reversing.

⚠ It is always the driver's responsibility to detect obstacles and estimate the vehicle's distance from them. Some overhanging objects, barriers, thin obstructions or painted surfaces which could possibly cause damage to the vehicle may not be detected by the system. Always be vigilant when using parking assist.

⚠ Do not turn and hold the steering on full lock for any more than 10 seconds. If the steering is held on full lock for more than 10 seconds the power steering pump can fail.

⚠ The rear sensors are not ON when neutral is selected, therefore care should be taken if moving the vehicle as the warning sound will not be heard.

⚠ Do not clean the sensors with abrasive or sharp objects.

📖 For reliable operation, the sensors in the front and rear bumpers should be kept free from ice, frost and grime.

📖 When using a high pressure spray the sensors should only be sprayed briefly and not from a distance of less than 200 mm. Do not clean the sensors with abrasive materials.

When activated, a warning will be heard when driving forwards or rearwards, if objects are detected within range of the vehicle.

Operation

⚠ If you are driving in a confined space, such as a home garage, the outer sensors will detect the side walls and after three seconds the tone will stop. However, as movement continues, the inner sensors will eventually detect the rear wall and will start the tone again.

⚠ In heavy rain or similar adverse conditions, the rear parking assist sensors may not always be able to accurately measure distance to close objects. A fully laden vehicle or irregular obstacles may also cause inaccurate measurements.

The parking assist system defaults to OFF when the ignition is set to ON. The system comes ON when reverse gear is selected, or if the parking assist button (A) is pressed at speeds below 17 km/h (10 mph). The system will set to OFF when the vehicle moves forwards above 17 km/h (10 mph). The parking assist button LED will come ON when the system is set to ON.



If an obstacle is detected at the front or rear of the vehicle, a series of beeps will be heard from the front or rear speaker respectively, which increases in rate as the vehicle nears the obstacle.

The beep becomes a continuous tone when an obstacle is detected at or within approximately 300 mm from the rear or 250 mm from the front of the vehicle.

The LED will flash if a fault is detected in the system and a single three second tone will be heard (only once per ignition cycle). The system is automatically disabled when a fault is detected.

 *Parking assist may sound spurious tones if it detects an ultrasonic frequency using the same band as the sensors.*

 *The system consists of inner and outer sensors. When manoeuvring forward into a garage, the front outer sensors will cease detection if they detect a stationary or receding object for three seconds or more, this allows detection directly at the front of the vehicle in this type of manoeuvre.*

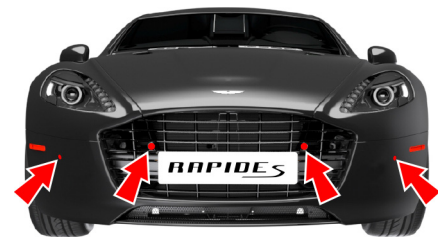

Reversing Camera

 **Warning:** *The parking camera does not replace the need for total vigilance and caution when parking or reversing.*

 **It is always the driver's responsibility to detect obstacles and estimate the vehicle's distance from them. When parking or reversing make full use of rearward and forward vision and all mirrors to be aware of persons or objects in the vicinity of the vehicle. Take appropriate measures to protect them from danger.**

 *For reliable operation, the parking camera lens in the rear bumper should be kept free from ice, frost and grime.*

 *When using a high pressure spray the parking camera lens should only be sprayed briefly and not from a distance of less than 600 mm. Do not clean the camera lens with abrasive materials.*

In addition to the parking assist system, a rear parking camera, located above the rear registration number plate (A), gives a view from the rear of the vehicle as the vehicle is moved backwards while parking or reversing. When reverse gear is selected the camera view is shown on the infotainment screen.



If the infotainment screen is ON when reverse gear is selected the screen will show the camera view until reverse gear is deselected. When reverse gear is deselected the screen will continue to show the camera view for approximately ten seconds or when the vehicle reaches a speed of 16 km/h (whichever is sooner), then return to the infotainment screen.

Press the **BACK** button to move between the parking camera and infotainment screens, at any time, while reverse is selected. If the infotainment screen is OFF the screen will raise when reverse gear is selected and lower when reverse gear is deselected.

The screen can be set to not raise when reverse gear is selected if the infotainment screen is OFF. Press **MENU** and navigate to <SYSTEM SETTINGS> **ENTER** <Disable rear camera if display off>. Press **ENTER** to set the camera ON or OFF, and then press **BACK** to return to the previous screen(s).

Camera Operation

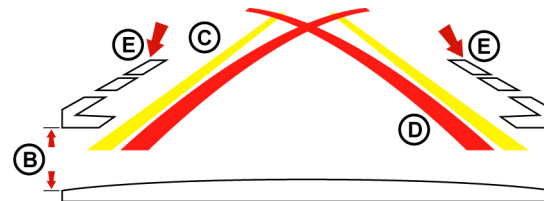

The camera overlay shows the fixed movement angle of the rear of the vehicle with the road wheels on full lock (D) red lines and the actual movement of the vehicle road wheels (C) yellow lines. As the steering wheel is turned the yellow lines will show the predicted vehicle movement.

The outer edge of the two markers (E) show the width of the vehicle including the mirrors.

The distance from the beginning edge of the two markers (E) to the rear of the vehicle is 300 mm (B).



Infotainment

Infotainment Controls.....	6.2
Infotainment System.....	6.2
Infotainment Personalisation.....	6.4
Bluetooth Pairing.....	6.5
Vehicle Status.....	6.6
Media Screen.....	6.8
Apple CarPlay.....	6.8

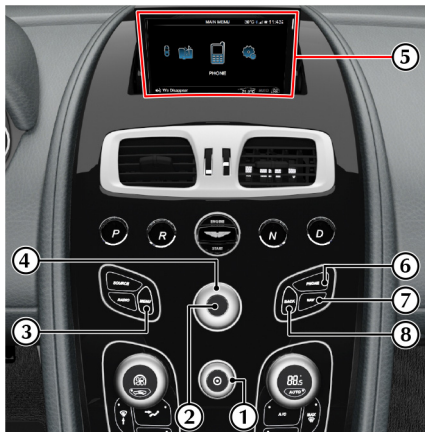

[1] **VOLUME/ON/OFF:** Volume control. Press to mute the audio system. Press and hold to turn the infotainment screen on or off.

[2] **ENTER:** Press to confirm selection of an item or option.

[3] **MENU:** Opens the main menu.

[4] **JOYSTICK:** Use to navigate in menus.

[5] **DISPLAY:** Shows options, menus and information.

[6] **PHONE:** Press to open the phone menu.

[7] **NAV:** Press to open the navigation menu.

[8] **BACK:** Move back in the menu or cancel a selection.

The infotainment system provides control over a number of systems in the vehicle. These systems include:

- Parking Cameras
- Satellite Navigation
- Audio Media
- Hands-free Phone
- Tyre Pressure Monitoring
- Vehicle Power Output Displays

Menu Paths

Menu paths are shown for each operation in the following format:

<item to select> **BUTTON TO PRESS**

For example: <Sound settings...>**ENTER**

Several menu options require a tick in a box to select an option. Once the menu item is highlighted press **ENTER** to either check or uncheck the box. Then press and hold **BACK** to accept and return to the main screen.

 In this chapter when asked to 'Press' a button, this means 'Press and release'. When this is not the case it will be clear in the text.

When asked to press **ENTER**, this means press the centre of the joystick.

Using the Controls

The console has touch sensitive glass surface buttons. The button area vibrates (haptic feedback) to acknowledge that the system recognises that the button has been pressed. To turn the haptic touch feedback on or off when pressing the buttons, access the *SYSTEM SETTINGS* menu and select <Centre Stack>.

Turn the joystick to access different menus. Press the joystick to confirm a menu selection (this is also referred to as **ENTER**).

Infotainment On and Off

The infotainment system is available with the vehicle key at least in position 'I' and is available until the vehicle key is removed from the ignition control.

 Pressing the **RADIO** or **SOURCE** buttons changes the current infotainment source.

ON/OFF: Short Press and Release

If an audio source is ON and playing, one short press will switch the audio playback to OFF and any media playback will be paused if applicable. The screen will show the main menu.

If there is no working media application, one short press will start playback of the previous media source. If the navigation application is OFF, the 'Now Playing' screen of the media source is shown. If the navigation application is ON, the current screen stays shown and the audio source works in the background.

ON/OFF: Long Press and Release

One long-press and release sets the screen to ON / OFF and raises or lowers the screen accordingly.

Operation

When the infotainment system is switched ON, the screen rises from the console to display the Aston Martin Welcome screen and model name.

The welcome screen fades to display the main menu. At any time while the infotainment system is ON press **MENU** to view the Main Menu screen.

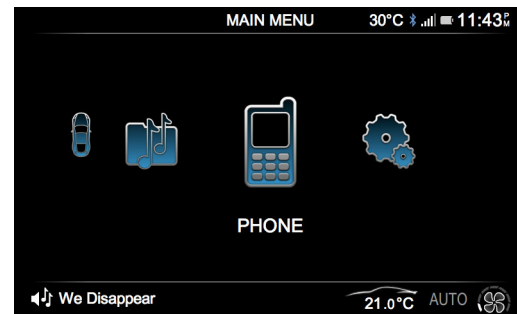

Use the **JOYSTICK** to navigate the menu system. Select from:

- REVERSE CAMERA
- VEHICLE STATUS
- NAVIGATION
- AUDIO
- PHONE
- APPLE CARPLAY
- SYSTEM SETTINGS

Infotainment Personalisation

The infotainment screen can be personalised with a choice of display languages, background images and text colours.

Colour Settings

To change the display colours, access the *SYSTEM SETTINGS* menu.

Press **ENTER** <Appearance> **ENTER** <Colour Settings>. Select from:

- Flugplatz Blue
- Volcano Red
- Cinnabar Orange
- Sunshine Yellow
- Appletree Green
- Lightning Silver
- Transparent

Image Settings

To change the display back ground, access the *SYSTEM SETTINGS* menu. Press **ENTER** <Appearance> **ENTER** <Image Settings>. Select from:

- Carbon Fibre
- None
- Highlight
- Water Droplets
- Leather
- Cedar
- Sand

Language

 Setting an infotainment language will also set the navigation voice language if one is available. The navigation voice language can be set independently from the infotainment in the navigation settings menu.

To change the language in the infotainment, access the *SYSTEM SETTINGS* menu. Press **ENTER** <Language>. Select from:

- English (UK)
- English (US)
- French
- Spanish
- German
- Italian
- Japanese
- Russian
- Swedish
- Czech
- Polish
- Chinese (Simplified)
- Chinese (Traditional)
- Greek

Bluetooth Pairing

A mobile phone, tablet or other device¹ can be connected using Bluetooth®² wireless technology for hands-free call functions and to stream music to the infotainment system.

 *Mobile phones must support A2DP Bluetooth® wireless technology. All streaming features are mobile phone and network dependent.*

¹. Bluetooth® devices will be referred to as 'phone' or 'mobile phone' in this manual.
². The Bluetooth® word mark and logos are registered trademarks owned by Bluetooth SIG, Inc., and any use of such marks by Aston Martin is under license. Other trademarks and trade names are those of their respective owners.

Device Pairing

Use this procedure when pairing the first mobile phone to the infotainment system.

Press **PHONE** and select **ADD A NEW HANDSET**. Press **BACK** to cancel. Press **ENTER**.



The infotainment system will ask if Bluetooth® wireless technology is in discoverable mode (refer to the mobile phone manufacturer's instructions). If yes, press **ENTER**.

Follow the mobile phone manufacturer's instructions to search and connect to a new Bluetooth® wireless technology device. The phone will search for discoverable Bluetooth® wireless technology devices in its range.

Select *Rapide S* from the device list.

 *If Rapide S does not show then check that the infotainment system is ON and search again*

Follow the instructions shown on the phone and the display to pair the phone.

Once synchronising has completed the mobile phone is ready for use with the vehicle audio and hands-free system. The vehicle will also request access to call history and messages.³

³. Dependant on phone model and software.

Vehicle Status

To add more devices when a device is already connected, press **PHONE** and then navigate to *BT Devices* to open the device manager. Select *ADD A NEW HANDSET* and follow the above steps to add an additional device.

⚠ Warning: Failure to avoid potentially hazardous situations could result in an accident or collision resulting in death or serious injury.

⚠ Warning: The vehicle status screens are intended for track only. It is the driver's responsibility to use these features in a responsible manner. Always use your best judgement, and operate the vehicle in a safe manner. Minimise the amount of time spent viewing the screen while driving and always be fully aware of all driving conditions.

⚠ Warning: Do not allow yourself to become distracted and minimise the amount of time spent viewing the screen while driving and always be fully aware of all driving conditions.

Display Units

To change the units shown on the vehicle status screens (Refer to 'Display Units', page 4.16).

Tyre Status

The infotainment display can show a tyres status screen which shows tyre pressure and temperature on a larger display. To show the tyre status screen, navigate to *<VEHICLE STATUS>* **ENTER** *<Tyre Status>*.

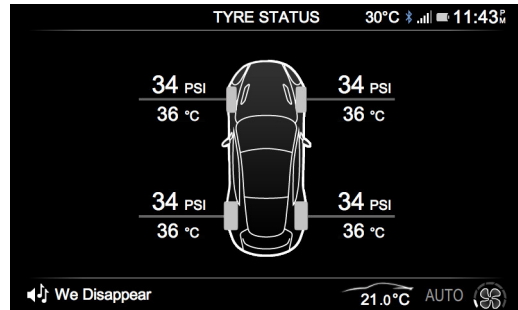

 The tyre status screen is to be used as a visual support for the TPMS indicator in the message centre. If the tyre status screen is not selected in the infotainment screen and a tyre fault does occur, warnings will **only** appear in the message centre.

 Tyre temperatures are indicative only and can vary with driving conditions and should not be used to assess the condition of a tyre. Always use the tyre pressure to check for correct inflation and visual inspection for tyre condition.

Power Meter

 **The power meter is intended for track use only.**

The infotainment system is able to show vehicle's engine power and torque as a live updated display. To show the display, navigate to <VEHICLE STATUS> **ENTER** <POWER METER>.

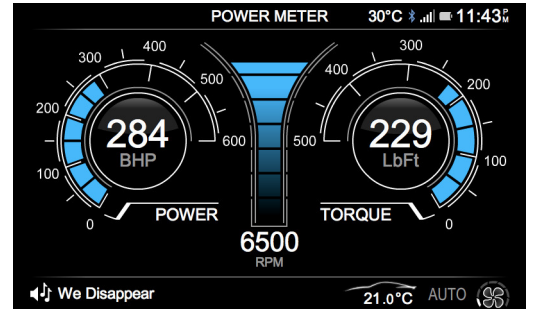

The screen will show both power and torque along with engine speed. On the power and torque dials there will be two readings:

[1] LIVE VALUE: Instant values as read from the vehicle. Shown in selected infotainment display colour (Refer to 'Infotainment Personalisation', page 6.4)

[2] PEAK VALUE: Peak values are shown in grey. These values are removed:

- After 8 Seconds.
- When value is exceeded and a new peak value is reached.

 Indicated values may differ from quoted manufacturer figures due to a number of driving environment differences such as, but not limited to, temperature, altitude, air density and engine load and, as a result, accuracy of data is not warranted. Any differences in values should not be taken as an indication of an engine not performing correctly.

Media Screen

(RSE Option only)

The infotainment screen can be used while the vehicle is parked as an auxiliary display for the Rear Seat Entertainment (RSE) system. From the AUDIO menu, select the <CD/RSE> option. Push the **JOYSTICK** up to show the media display.

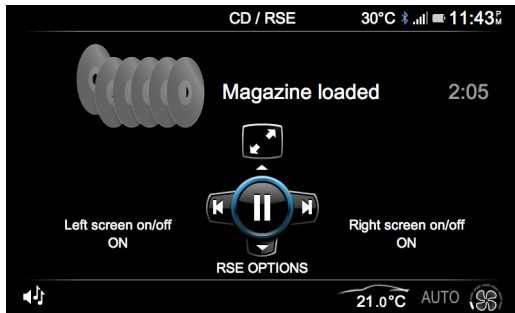

 The media display feature is automatically deactivated when the vehicle speed exceeds 5 Mph

Controls

DVD Menu

The **JOYSTICK** is used to control the DVD menu control. Push the **JOYSTICK** left, right, up, or down to navigate the menu. Press **ENTER** to confirm selection.

Media Playback

During media playback, push the **JOYSTICK** left to go back a chapter or right to skip to the next chapter. Press and hold left or right to rewind or fast forward. To rotate the **JOYSTICK** to change the disc.

Apple CarPlay

Apple CarPlay is a smarter, safer way to use your iPhone or other compatible Apple device in your vehicle by using the vehicle infotainment screen. When connected, the infotainment system can be used to make calls, send and receive messages, view navigation and listen to music.

 By using Apple CarPlay, you acknowledge the following: Apple CarPlay is a service provided by Apple Inc. under its terms and conditions. Aston Martin Lagonda is not responsible for Apple CarPlay or its applications. When using Apple CarPlay, certain information from your vehicle (such as its position) is transferred to your iPhone.

Initial Connection

1. Connect the iPhone to the CarPlay USB port (A) with a suitable cable.

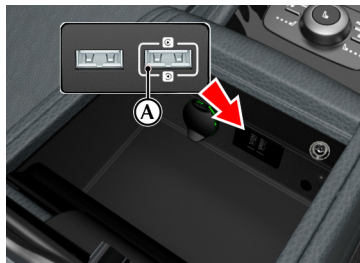

2. Navigate to the **CARPLAY** icon from the main menu and press **ENTER**.
3. The Apple CarPlay menu will now open.



To begin Apple CarPlay, select the **CARPLAY** icon from the *Infotainment* menu and press **ENTER**. The Apple CarPlay menu will then open.

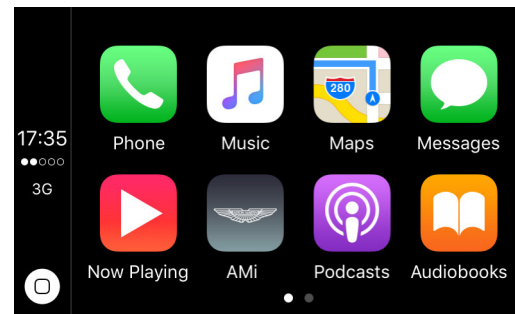

Apple CarPlay Controls

Whilst in the Apple CarPlay system, use the **JOYSTICK** to navigate the menus and **ENTER** to select items.

 Information about which apps are supported and which phones are compatible is available on Apple's Website www.apple.com/ios/carplay.

To exit CarPlay and return to the vehicle menu press the **AMi** app in the CarPlay menu. The **MENU**, **NAV** and **RADIO** buttons will also function as normal and will open menus outside of CarPlay.

 The **PHONE** function, **PHONE** button and second **USB** port are all disabled when Apple CarPlay is in use. Devices connected to the vehicle with Bluetooth or USB will not be available when Apple CarPlay is active.

When CarPlay is connected, **SOURCE** is used to return to the main CarPlay screen. **SOURCE** will not change between audio sources whilst CarPlay is connected.

SIRI

Apple CarPlay apps can be voice operated using SIRI. To activate SIRI press and hold the **CALL** button.



ASTON MARTIN



ASTON MARTIN

Climate Control

Operating Tips	7.2
Climate Controls	7.2
Airflow Modes.....	7.4
Automatic Operation	7.5
Manual Operation.....	7.6
Rear Environment.....	7.7



Operating Tips

- A solar sensor is installed on top of the instrument panel, this should not be covered when driving.
- The intake grille of the in-vehicle temperature sensor is located in the driver's knee bolster, close to the centre console. To maintain the optimum temperature this grille should not be obstructed.
- Moisture which forms on the evaporator in the air conditioning unit is discharged via a drain tube onto the road. After stopping, small puddles of water may form underneath the vehicle. This is normal and does not show a system malfunction.
- Operate the climate control system with the engine operating.
- Clear all obstructions like leaves, snow and ice from the bonnet and the air inlet in the front grille to improve the system efficiency.
- Windows can fog up easily in humid weather. Use the climate control system to demist the windows.
- To help demist the windows, operate the air conditioner to dehumidify the air.
- Use the 'outside air' position in normal conditions. The 'recirculated air' position should be used temporarily when driving on dusty roads or for quick cooling or heating of the interior.

- If the vehicle has been parked in direct sunlight during hot weather, open the windows to let warm air escape, then close the windows and operate the climate control system.
- Operate the climate control system at least once a month to keep internal parts lubricated.
- Have the climate control system checked before the weather gets hot. If the climate control system is low on refrigerant or has a malfunction, consult your Aston Martin Dealer.
- This vehicle is equipped with a pollen filter. It is necessary to change the filter periodically as shown in the scheduled maintenance. Consult your Aston Martin Dealer.
- Air conditioning may not function when the outside temperature approaches 0°C (indicator stays ON even when system is OFF).

Climate Controls

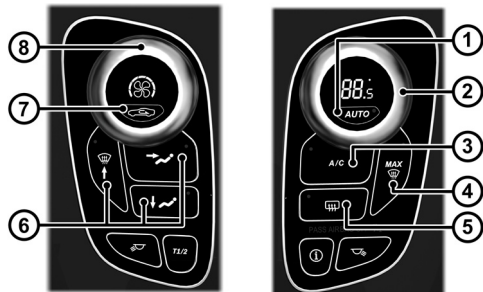

[1] AUTO: Press for automatic climate control operation (Refer to 'Automatic Operation', page 7.5).

[2] TEMPERATURE: Set the required in vehicle temperature. Turn clockwise for hot and counter-clockwise for cold. The selected temperature is shown on the dial display.

[3] A/C: When in manual mode press and release to set the air conditioning ON or OFF.

[4] MAX : Press for maximum defrost or demist ON or OFF. Outside air intake is automatically selected and air conditioning is automatically started.



[5] HEATED REAR WINDOW: Press to operate the rear window heater. Goes OFF after 20 minutes if not manually set to OFF. When the heated rear window is ON the door mirror heaters will work for 6 minutes, then go OFF.

[6] AIRFLOW MODES: Press and release to select an airflow mode. (Refer to 'Airflow Modes', page 7.4)

⚠ Warning: Do not select recirculated air in cold or rainy weather, it can cause the interior glass to mist up.

[7] AIR CIRCULATION: Controls the source of air entering the vehicle. Press to select recirculated air (button LED ON). Press again to select outside air as source.

Use the recirculated air position when going through tunnels, driving in congested traffic (high engine exhaust areas) or when maximum cooling is required. On start up the default position is outside air as source. Use this position for normal conditions and demisting.

[8] FAN SPEED: Turn to set the required fan speed (clockwise for fast speed and counter-clockwise for low speed). The fan speed is shown on the display.

Display Units

To change the display units to show Celsius (°C) or Fahrenheit (°F) (Refer to 'Display Units', page 4.16)

Solar and Temperature Sensors

The automatic air conditioner function measures inside and outside temperatures, and sunlight. It then sets the interior temperature accordingly. To maintain effective operation do not obscure the following sensors:

[1] : Solar sensor.

[2] : In-vehicle temperature sensor.

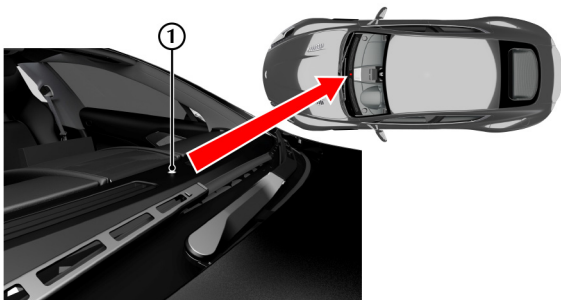

Airflow Modes

Press and release each button for an airflow mode. By pressing one or more buttons at a time, five airflow modes are available. Selected airflow modes are also shown on the infotainment screen.

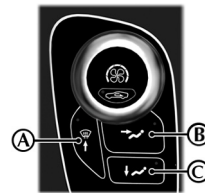

Mode	Button(s)
Windscreen and Door Windows <i>In addition a small bleed of air is directed into the face vents.</i>	(A)
Face Only	(B)
Feet Only <i>In addition a small bleed of air is directed to the face vents, the windscreen and door windows.</i>	(C)
Windscreen, Door Windows and Feet <i>In addition a small bleed of air is directed into the face vents.</i>	(A)+(C)
Face and Feet	(B)+(C)



Adjusting the Vents

To adjust the air flow vents:





Automatic Operation

Press **AUTO**. Using the **TEMPERATURE** dial set the required in-vehicle temperature (read the actual temperature setting in the top left of the display). The **A/C** button LED will come ON.

Adjustments to fan speed, air flow and air re circulation will be made automatically according to the set temperature, interior and exterior conditions.

 *Maximum fan speed will not be available to heat the cabin until the engine has reach its normal operating temperature.*

 *When using the air conditioner, mist may come out from the vents. This is not a sign of trouble but a result of humid air being suddenly cooled.*

 *If resetting climate control functions other than the fan speed, the fan speed will stay set as in automatic mode. Adjustments to the fan speed will cancel Auto Mode.*

Defrost and Demist

! *To defrost or demist the windscreen on vehicle start up in extreme cold weather conditions, operate the engine at 1500 rpm. Always make sure that the transmission is in P (park) and the park brake is applied.*

Press **MAX** . The outside air intake is automatically selected, the temperature is set to maximum and air conditioning is started.

 *If the cabin temperature is cold the air conditioner will not start up until the engine has started to warm up.*

To cancel automatic defrost or demist either:

- Press **MAX**  again.

or

- Press **AUTO**.

or

- Press any of the airflow mode buttons.

 *The automatic defrost setting times out after 6 minutes.*

Manual Operation

Set the required:

- Fan speed
- Temperature
- Air flow.

 *The fan speed and temperature setting will show on the display.*

 *When using the air conditioner, mist may come out from the vents. This is not a sign of trouble but a result of humid air being suddenly cooled.*

 *Setting the temperature to maximum high or low will not provide the required temperature at a faster rate. To prevent cool air blowing from the vents when heating immediately after starting a cold engine, the amount of airflow is reduced until the air warms up.*

 *The vehicle heater will continue to produce the selected temperature regardless of in-vehicle conditions.*

If dehumidifying is required, press the **A/C** button (LED ON). To stop dehumidifying press **A/C** button again (LED OFF).

When maximum cooling is required, set the **TEMPERATURE** dial to the extreme cold position and press the **AIR CIRCULATION** button to the re circulated air position ( will show in the display), then set a fast fan speed.

Defrost and Demist

! *To defrost or demist the windscreen on vehicle start up in extreme cold weather conditions, operate the engine at 1500 rpm. Always make sure that the transmission is in P (park) and the park brake is applied.*

Press **A/C**. Press the   airflow button.

Set the required:

- Temperature
- Fan speed.

 *If the engine is cold the air conditioning will not start up until the engine has started to warm up.*

 *For maximum defrost or demist set the temperature and fan speed dials to maximum.*

Control of the Rear Climate

Press and release **REAR A/C** to set the rear climate from the front controls. Once pressed set the fan speed, temperature, airflow mode¹ and A/C for the rear environment. If no buttons are pressed, after seven seconds the control returns to the front.

Press **REAR A/C** and hold for two seconds and release to lock or unlock the rear controls. When the rear climate controls are locked the **REAR A/C** LED will show. When locked the rear controls can not be used and the interior climate is set only by the front controls.

¹. Not shown on screen.

Rear Environment

Controls



[1] DISPLAY: Shows the fan speed or temperature when selected.

[2] DIAL: When temperature, fan speed or seat climate control buttons are selected, turn to set temperature or fan speed.

[3] MODE: Press and release to select temperature or fan speed. Defaults to fan speed.

[4] A/C: Press and release to set the rear air conditioning to ON or OFF.

[5] AIRFLOW: Select the required airflow.

Operation

When the rear climate system is unlocked at the front controls, set the fan speed, temperature, air flow and A/C for the rear environment from the rear controls.

 The **DISPLAY** will not show when control is from the front.

 Rear air conditioning is only available when the front air conditioning is set to ON.

 Maximum fan speed will not be available until the engine has reached its normal operating temperature.

Press **MODE** to select fan speed or temperature. Turn the **DIAL** to set the required fan speed (clockwise for faster and counter-clockwise for slower) or temperature (clockwise for warmer and counter-clockwise for cooler).

Press and release each **AIRFLOW** button to select an airflow mode. By pressing one or more buttons at a time, three airflow modes are available. When no airflow mode is selected the rear climate system sets to OFF.

 When no airflow mode button is selected there is a small time delay before the rear system sets to OFF.

To assist the front climate control when the interior is either too warm or too cold, when the front climate system is set to either **AUTO** and maximum high or **AUTO** and maximum low temperature the rear system follows as detailed, regardless of it's current state:

 The front climate controls must be set to maximum high or maximum low temperature.

Auto High: The rear system will set to ON at maximum high temperature and fan speed, the airflow mode will be foot mode.

Auto Low: The rear system will set to ON at maximum low temperature and fan speed, the airflow mode will be face mode.

Any adjustment, during this time, to the rear climate controls will override these conditions. When front auto high or low is stopped the rear system will return its previous state.

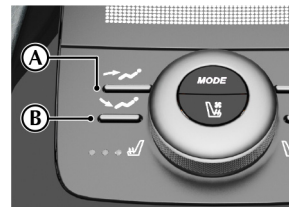

Mode	Button(s)
Face Only	(A)
Feet Only	(B)
Face and Feet	(A)+(B)

Press **A/C** if air conditioning is required.

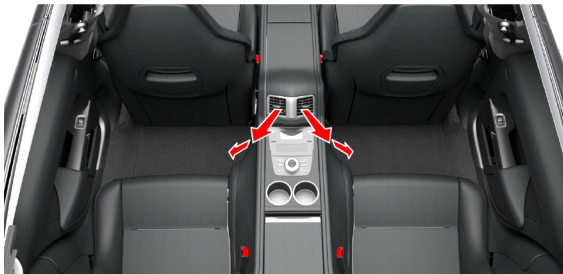

Adjusting the Vents

To adjust the air flow vents:

 *The rear vents can not be set to OFF.*





ASTON MARTIN



ASTON MARTIN



ASTON MARTIN

Audio

Audio Essentials.....	8.2
Audio Controls.....	8.4
Radio Functions.....	8.6
Traffic Announcements.....	8.8
Automatic Frequency Updating.....	8.9
Radio Data System.....	8.9
DAB Radio Functions.....	8.9
iPod and USB Functions.....	8.11
Auxiliary Functions.....	8.13
Bluetooth Streaming.....	8.14
CD Player Magazine.....	8.14
CD Player Functions.....	8.15



Audio Essentials

Aston Martin Premium Audio

Radio:

- Digital Audio Broadcasting (DAB) radio.
- AM and FM radio.

Audio Inputs

- USB Device
 - 2 x Connection port in cubby box.
 - iPod / iPhone / iPad Compatible.¹
- Auxiliary Input
 - 1 x 3.5mm Connection port in cubby box
- Bluetooth® Wireless Technology
Audio and hands-free phone.

Rear Entertainment System (Option): Six DVD autochanger with two seat mounted screens.

Power Output: 600W.

Speakers

[1] : Two 25 mm tweeters.

[2] : Centre: Two speakers: One 90 mm mid-range in closed cabinet and one 19 mm (soft dome) tweeter.

[3] : Footwell: Two 140 mm woofers in closed cabinets.

[4] : One 90 mm mid-range speaker, in closed cabinet, in each front door.

[5] : One 200 mm subwoofer housed in closed cabinet in the left side boot wall.

[6] : Two speakers, one 90 mm mid-range and one 19 mm (soft dome) tweeter, in each rear door.

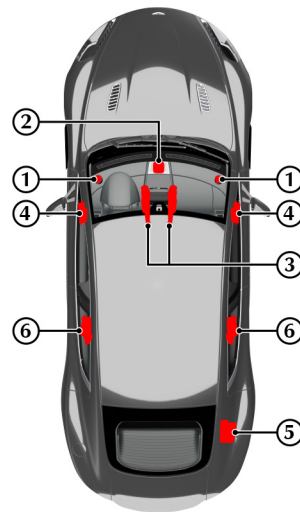

¹ iPod iPhone and iPad are trademarks of Apple Inc.

Bang & Olufsen BeoSound Audio

Optional

Radio:

- Digital Audio Broadcasting (DAB) radio.
- AM and FM radio.

Audio Inputs

- USB Device
 - 2 x Connection port in cubby box.
 - iPod / iPhone / iPad Compatible.¹
- Auxiliary Input
 - 1 x 3.5mm Connection port in cubby box
- Bluetooth® Wireless Technology Audio and hands-free phone.
- Six CD autochanger (optional).

Rear Entertainment System (Option): Six DVD autochanger with two seat mounted screens.

Power Output: 1000W

¹ iPod iPhone and iPad are trademarks of Apple Inc.

Speakers

[1] : Two 19 mm (soft dome) tweeters incorporating Acoustic Lens Technology (ALT).

[2] : Centre: Two speakers: One 90 mm mid-range in closed cabinet and one 19 mm (soft dome) tweeter.

[3] : Footwell: Two 140 mm woofers in closed cabinets.

[4] : One 90 mm mid-range speaker, in closed cabinet, in each front door.

[5] : One 200 mm subwoofer housed in closed cabinet in the right side boot wall.

[6] : Two speakers, one 90 mm mid-range and one 19 mm (soft dome) tweeter, in each rear door.

[7] : One 140 mm woofer in each rear door.

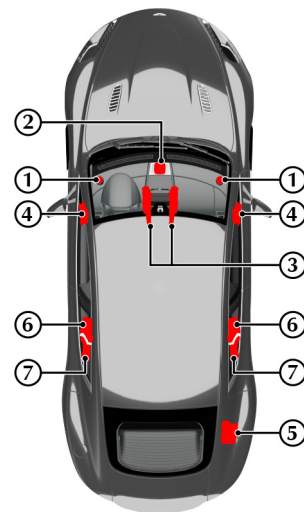

Audio Controls

Acoustic Lens Technology

(Bang and Olufsen audio only)
Acoustic Lens Technology (ALT) gives a wide (180°) horizontal dispersion of high frequencies. This prevents the loss of critical sound and gives listeners an improved sense of space, staging and realism, even when not sitting in the optimal location¹ for listening to two-channel stereo reproductions.



Two motorised acoustic lenses, mounted on either side of the dashboard, rise when the system is set to ON and stay raised until the audio system is set to OFF.

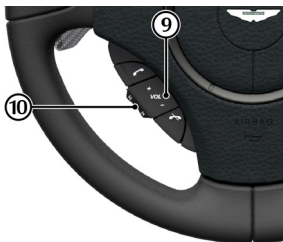
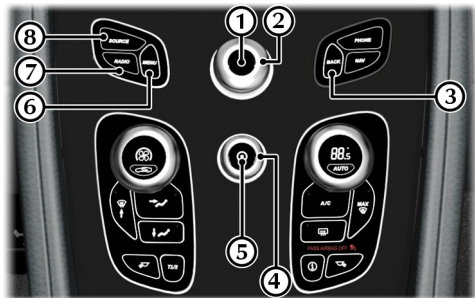

[1] **ENTER:** Push the **JOYSTICK** button (referred to as **ENTER** throughout this chapter) to select items within a menu or to open a selection.

[2] **JOYSTICK:** Navigate in the menus by clicking left, right, up or down. Turn the rotary controller to scroll menu items.

[3] **BACK:** Press to move back one action. Press and hold to move back to the default screen.

[4] **VOLUME:** Volume control.

[5] **ON/OFF:** Press for audio ON and OFF.

[6] **MENU:** Opens the main menu.

[7] **RADIO:** Press to navigate between the radio bands.

[8] **SOURCE:** Press to select other audio sound sources.

[9] **VOLUME:** Volume control.

[10] **SCROLL:**

- **Radio:** Searches up and down the frequency band for the next available radio station.
- **iPod / USB:** Skip forward or backwards through music tracks.

¹ For the optimal location to listen to two-channel stereo reproductions, the listener should be sitting equidistant from both loudspeakers on the apex of an equilateral triangle.

Operation

The audio system is available with the vehicle key at least in position '1' and is available until the vehicle key is removed from the ignition control.

If the audio system is ON when the ignition is set to OFF and the vehicle key removed, it will automatically start the next time the vehicle key is moved to position '1'.

Press **ON/OFF** to set the audio system ON or OFF.

Sound Source

To select radio, at any time while the audio system is ON, press the **RADIO** button repeatedly to navigate between the radio bands.

To select other audio sound sources press the **SOURCE** button to navigate through the audio source choices.

Battery Protection Mode

Using the audio system, with the vehicle key at position '1' (ignition OFF) will drain the battery charge. A warning message will show in the message centre when the battery charge is low (Refer to 'Battery Protection Mode', page 12.20). The audio and USB ports are disabled after a two minute warning to protect the battery.

Menus

Press **MENU** to access the main menu to navigate to the required location.

Aston Martin Audio Sound Settings

To access sound settings, select <SETTINGS> from the <AUDIO> menu. Select <AUDIO SETTINGS> press **ENTER**. Select required features and adjust to desired settings.

Bass: Level for bass.

Treble: Level for treble.

Balance: Balance between the left and right speakers.

Fader: Balance between the front and rear speakers.

Surround: Level for surround sound.

Auto Volume Control: Auto volume control adjusts tone based on the output level to maintain tonal balance at all volume levels.

Select from <Off>, <Low>, <Medium> and <High>.

Sound Field

The focus of the sound from the audio system can be optimised for either the driver, the driver and front passenger, the rear passengers or all front and rear passengers. Select:

 *The audio system detects seat occupancy by seat belt engagement.*

Driver: The focus of the sound is optimised for the driver only.

Front: The focus of the sound is optimised for both the driver and the front passenger.

All: The focus of the sound is optimised both for the front and the rear passenger(s).

Bang & Olufsen Audio Sound Settings

To access sound settings, select <SETTINGS> from the <AUDIO> menu. Select <AUDIO SETTINGS> and press **ENTER**. Select required features and adjust settings using the rotary joystick and press **ENTER** to confirm.

Bass: Level for bass.

Treble: Level for treble.

Balance: Balance between the left and right speakers.

Fader: Balance between the front and rear speakers.

Surround: Level for surround sound.

Auto Volume Control: Auto volume control adjusts tone based on the output level to maintain tonal balance at all volume levels. Select from <Off>, <Low>, <Optimum>, and <High>.

Sound Focus

The focus of the sound from the audio system can be optimised for either the driver, the driver and front passenger, the rear passengers or all front and rear passengers. Select:

 *The audio system detects seat occupancy by seat belt engagement.*

Driver: The focus of the sound is optimised for the driver only.

Front: The focus of the sound is optimised for both the driver and the front passenger.

Rear: The focus of the sound is optimised for both rear seat passengers.

All: The focus of the sound is optimised both for the front and the rear passenger(s).

Radio Functions

Radio Menu

From the AUDIO menu, select the <RADIO> option to display the radio menu.

The RADIO menu allows you to select <AM>, <FM>, <DAB> and <SETTINGS>.

 *In the RADIO menu, a music note icon appears above the current radio frequency image.*

 *DAB is market specific.*

Automatic Tuning

To automatically tune stations:

1. From the RADIO menu, select <AM>, <FM> or <DAB> to display the specific tuner.

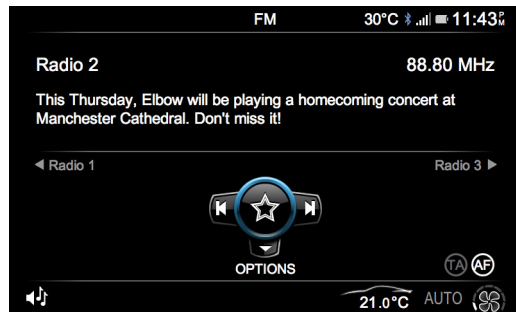

2. Press the **JOYSTICK** left to select the previous available station or right to select the next available station.
3. Rotate the **JOYSTICK** to view the list of available stations
4. Press **ENTER** to view the favourites list.

Manual Tune By Frequency

To tune AM or FM stations manually:

1. From the RADIO screen, push the **JOYSTICK** down to select <SETTINGS>. The SYSTEM SETTINGS screen is shown.
2. Select <Manual Tune> and press **ENTER** to confirm.
3. Rotate the **JOYSTICK** to manually search for stations.
4. Push the **JOYSTICK** up or down to move along the frequency band by 1.0MHz for faster searching.
5. When the desired frequency is reached, press **ENTER** to confirm.

Station List

To view and select from the list of available stations:

1. From the RADIO screen, push the **JOYSTICK** down to select <RADIO OPTIONS>.
2. Select <Station List> from the list and press **ENTER** to confirm.

Or:

1. From the RADIO screen, rotate the **JOYSTICK**. A new window appears displaying the list of available stations.
2. Rotate the **JOYSTICK** or push it up and down to select a specific station.
3. Press **ENTER** to confirm.

The selected station then starts playing.

Favourite Stations

To view and select a favourite station:

1. From the RADIO screen, push the **JOYSTICK** down to select *<OPTIONS>*.
2. Select *<Favourites>* from the list and press **ENTER** to confirm. Only stations saved as a favourite are shown in the list.

Or:

1. From the RADIO screen, press **ENTER**. A new window appears displaying the list of favourite stations.
2. Rotate the **JOYSTICK** or push it up and down to select a specific station.
3. Press **ENTER** to confirm.
The selected favourite station then starts playing.

Adding A Favourite Station

Press and hold **ENTER** to add the current station to your favourites list.

Sort Stations

The list of available or favorite stations can be order either in alphabetical order or in frequency order. To change the sort order of stations:

1. From the RADIO screen, push the **JOYSTICK** down to select *<OPTIONS>*.
2. Select *<Sort>* from the list and choose either *<By Name>* or *<By Frequency>*. Press **ENTER** to confirm.

Traffic Announcements

The Traffic Announcement (TA) function makes sure that all traffic announcements interrupt radio programmes.

To turn the traffic announcement function ON or OFF:

1. From the NOW PLAYING screen, push the **JOYSTICK** down to select *<OPTIONS>*.
2. Select *<Traffic announcements>* from the list.
3. Press **ENTER** to switch between ON and OFF.

When the traffic announcements are ON, 'TA' is shown on the display.¹

¹. AM/FM Radio Only

Automatic Frequency Updating

(AM/FM Radio Only)

The Automatic Frequency (AF) updating function is normally ON and makes sure that the radio tunes to the strongest available transmitter.

To turn the automatic frequency ON or OFF:

1. From the RADIO screen, push the **JOYSTICK** down to select *<Options>*.
2. The RADIO OPTIONS screen is shown. Select *<Options>* from the list.
3. Select *<Tuner AF>*.
4. Press **ENTER** to switch between *<ON>* and *<OFF>*.

When automatic frequency is ON, then 'AF' is shown on the display.

Radio Data System

Radio Data System (RDS) is a system that links together specific network transmitters. It is used, for example, to tune the correct frequency of a station irrespective of the transmitter or the current audio source (e.g. CD). The system can also be used for receiving traffic information (TP) and for finding broadcasts of a specific type. Radio text is also a component of RDS. A radio station can transmit information about the radio programme currently being broadcast.

Messages with a programme code (such as news from RDS stations) will interrupt other audio sources at the volume set for this. As soon as the news broadcast is finished, the audio system returns to the previous audio source and resumes the previous volume setting.

 *Some radio stations do not use RDS or only use a limited range of its features.*

DAB Radio Functions

Digital Audio Broadcasting (DAB) radio broadcasts digitally via a network of transmitters. DAB radio provides more stations, more information and a clearer sound quality. DAB is market specific.

DAB Ensembles

DAB ensembles are groups of DAB broadcasters that transmit multiple digital radio stations on a single radio transmission. There are usually between 6-10 radio stations per ensemble.

 *If the vehicle is in motion and DAB reception is lost, the vehicle may be out of range of the ensemble.*

 *The DAB radio sound quality may be reduced if any auxiliary electrical equipment is connected to the vehicle.*

Learn

Learn scans the DAB radio frequencies and automatically repopulates the station list with all available stations. Learn is automatic and performs this scan in the background each time the audio is switched ON. To perform the learn process at any time, complete the following:

1. From the DAB screen, push the **JOYSTICK** down to select *<Options>*.
2. Select *<LEARN>* from the list. A message is shown in the screen explaining about the function.
3. Press **ENTER** to start the learn function.
4. The screen shows the progress status of the scan and the number of stations found. Once complete the station list is updated. The first station in the list is then played.

Current Station Information

To view current station information:

1. From the DAB screen, push the **JOYSTICK** down to select *<Options>*.
2. Select *<Station Info>* from the list.
3. The station name, ensemble name and frequency block for the current station are then shown.

Station Link

A DAB station link creates a link between the same DAB stations within different ensembles. Therefore if the radio reception on the current station drops below an acceptable level, the DAB system searches other ensembles and if the same station is found and has a better signal, then this station is then used. A 'no signal' message maybe shown whilst the system is searching.

To enable DAB links:

1. From the DAB menu, push the **JOYSTICK** down to select *<Options>*.
2. Select *<DAB link>* from the list.
3. Press **ENTER** to switch between *<ON>* and *<OFF>*.

Comfort Noise

Comfort noise is a low synthetic background noise which is used to fill the silence when using certain DAB functions. This indicates that the DAB system is still working.

To enable the comfort noise:

1. From the DAB menu, push the **JOYSTICK** down to select *<Options>*.
2. Select *<Options>* from the list.
3. Select *<Comfort Noise>*.
4. Press **ENTER** to switch between *<ON>* and *<OFF>*.

Skip AM

When selecting between different radio tuners using the **RADIO** button on the console, the selection can be limited by not showing AM stations. This makes it easier to select between FM and DAB radio tuners.

To skip the AM radio tuner when using the **RADIO** button for selection:

1. From the DAB menu, push the **JOYSTICK** down to select <Options>.
2. Select <Options> from the list.
3. Select <Skip AM>.
4. Press **ENTER** to switch between <ON> and <OFF>.

iPod and USB Connection

 *On initial connection and on every engine start the system will synchronise with the connected device. This will take a short while to complete.*

 *The iPod controls will not operate while connected to the vehicle audio system. All functionality will be from the vehicle audio system.*

 *Aston Martin recommend using a genuine Apple™ cable (available separately) when connecting an iPhone, iPod or iPad. Non-genuine cables can provide limited functionality.*

There are two USB sockets located in the front cubby box. Locate the required socket and connect:

- an iPod player using a suitable iPod USB cable.

 *If a Apple Carplay compliant device is connect to the Carplay USB socket, Apple Carplay will launch (Refer to 'Apple CarPlay', page 6.8).*

- a USB device.

If not already ON, set the audio system to ON. Press the **SOURCE** button to cycle the audio sources until either the required <iPod> or <USB> shows on the display.

The iPod or USB device can now be operated by the audio system and are shown and access in order of connectivity.

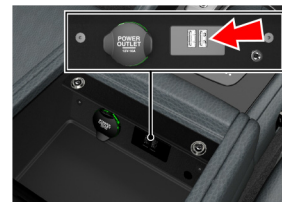

Playing Tracks

Once the mode has been set to either iPod or USB play automatically starts.



Selecting Tracks

Press the **JOYSTICK** down to show the music folder list. Select from <Tracks>, <Albums>, <Artists> and <Playlists> (if using an iPod) to navigate to the required music tracks. Press **ENTER** to open a folder or play a track.

Pause Mode

Press **ENTER** to pause a track whilst playing. Press **ENTER** again to start play.

When the volume is at zero, play will pause. Start play by turning the volume up.

Fast Forward and Rewind

Press and hold the **JOYSTICK** (left or right) to search within a track or the whole music folder. The search continues as long as the **JOYSTICK** is held.

Album Search

Press the **JOYSTICK** up to show available music albums. Any album art that has been previously synchronised will also be shown (Refer to 'Album Art', page 8.13). Rotate the joystick to search through available albums or quickly rotate the joystick to start a quick search. Press **ENTER** to select an album and begin audio playback.

Changing Tracks

Press the **JOYSTICK** (left or right) to play the next or previous track.

RDS Radio Stations

Traffic Announcements (TA) are also available when in USB or iPod mode. (Refer to page 8.8)

Auxiliary Functions

Album Art

When an iPod, iPhone, iPad or USB device is connected to the vehicle and a music album is played, album art for that music album is synchronised and stored on the vehicle. The album art will then be shown whenever the associated music is played.

To synchronise all available artwork from a device onto the vehicle, press the **JOYSTICK** down to show the music folder list. Select <Sync Artwork> and press **ENTER** to synchronise all available album art. A progress bar will be shown with the number of synchronised files and total number of files¹. Whilst album artwork is synchronising there will be no audio playback.

Any album art files previously saved will be passed over but included in the number of files to be synchronised. Synchronising can be stopped at any time by pressing **ENTER** again, or navigating away from the <Sync Artwork> screen. For example, pressing the **RADIO** button.

A maximum of 1000 album art files can be saved to the vehicle. Any further art that is added will replace the oldest unused files.

¹. The time taken will depend on number of files to be synchronised.

Audio Device Connection

The auxiliary input socket is provided to connect audio devices which can not be connected using the iPod or USB connections.

 *Only volume control will be available from the vehicle audio system. All other functionality will be from the audio device.*

Locate the auxiliary socket in the front armrest cubby box. Connect the audio device to the auxiliary socket using a suitable cable.

If not already ON, set the audio system to ON. Press the **SOURCE** button until AUX is highlighted on the display.

The media device now plays through the Infotainment system.



Audio Device Volume

The vehicle audio system volume can be set at a higher or lower starting volume for the audio device.

From the AUDIO menu, select <AUXILIARY INPUT> **ENTER** <AUXILIARY GAIN>. Rotate the **JOYSTICK** to set the auxiliary gain level.

Press **BACK** to return to the main display.

Bluetooth Streaming

 Bluetooth audio streaming is not available when a device is connected to Apple CarPlay.

Connecting a Mobile Phone or MP3 Device

Enable Bluetooth® wireless technology on the required mobile phone or MP3 device. The mobile phone or MP3 device must be paired to the vehicle. If the mobile phone or MP3 device is not yet paired, follow the pairing phones information (Refer to 'Bluetooth Pairing', page 6.5).

Selecting the Mobile Phone or MP3 Device

Select the required Bluetooth® enabled device by using the **SOURCE** button. All connected devices are shown in the Audio menu.

The artist, track name, album and time are then shown in the display.

 Some devices may play erratically if more than one device is connected by Bluetooth®. If such playback issues do occur, disconnect devices that are not in use.

Changing Tracks

Push the **JOYSTICK** (left or right) to play the next or previous track.

Changing tracks is also available from the mobile phone or MP3 device whilst connected via the Bluetooth® wireless technology.

Audio Volume

Upon initial connection, audio playback may be a lower volume than any other media inputs. The volume level of the device can also be increased or decreased independent of the vehicle's audio system. Please check that the device volume is not set too low.

Album Art

Album art is unable to be sent to the vehicle with a Bluetooth® connection. However if a music track is played and the album art associated with that track has previously been saved to the vehicle, then the album art will be shown. (Refer to 'Album Art', page 8.13)

CD Player Magazine

 **Do not leave the CD player door in the open position. If dirt or moisture enters the player this can reduce playback quality, and can result in damage to the player.**

The player is located in the right hand side of the boot.

To load or eject a disc:

1. Slide the player door fully open and press the **EJECT** button.
2. Remove the magazine and put in or eject a disc(s) into, with the label side facing upwards, or out of the magazine.
3. Place the magazine into the player and fully close the sliding door.

Do not place any device or object that emits a magnetic field near to the player.

Do not put in any object other than the recommended discs into the player for any reason.

Make sure that the discs are clean and dust free before inserting into the player.

CD Player Functions

 This product incorporates copyright protection technology that is protected by method claims of certain US patents and other intellectual property rights owned by Macrovision Corporation and other rights owners. Use of this copyright protection technology must be authorised by Macrovision Corporation, and is intended for home and other limited viewing uses only unless otherwise authorised by Macrovision Corporation. Reverse engineering or disassembly is prohibited.

Loading CDs

 **Use only 12 cm CDs. Do not use CDs with adhesive disc labels. The heat from the CD player can cause the label to come loose from the disc. The CD player could be damaged.**

 **Do not use CDs that are warped or look warped (critical measurement for CD warp is 0.7 mm - anything more than this may cause problems). The CD player will not be able to hold the CD correctly (because of the warp), this may cause a jam in the CD player.**

 If the quality of the CD does not comply with the requirements of standard EN60908 or if it has been recorded using poor equipment, sound quality may be poor or playback interrupted.

The CD changer can hold up to six discs.

Select **CD CHANGER** from the main AUDIO menu. The CD CHANGER screen shows the current disc that is playing.



The current CD that is playing is shown in colour and is positioned above the other CDs. CD and track information that is available is shown, which can include CD title, artist, track name and number.

Selecting a CD

In the CD CHANGER screen, push the **JOYSTICK** up or down to select the required disc to play.

Or rotate the **JOYSTICK** (left or right) to show a DISC LIST. Rotate the **JOYSTICK** in the list or push it up and down to select the required disc. Press the **JOYSTICK** to confirm the selection.

Changing Tracks

Push the **JOYSTICK** left or right to play the next or previous track.

Fast Forward and Rewind

Push and hold the **JOYSTICK** left or right to search forwards or backwards within a track or the whole disc. Searching continues for as long as the button is depressed.

Pause Mode

Press **ENTER** to pause a track whilst playing. Press **ENTER** again to start play.

When the volume is at zero, play will pause. Start play by turning the volume up.



ASTON MARTIN



ASTON MARTIN



Rear Seat Entertainment

Introduction	9.2
Disc Player Magazine	9.2
Supervisory Control	9.4
Rear Passenger Control	9.5
To Set the RSE Screens ON and OFF	9.6
System Settings	9.6
RSE Media Source	9.7
Headphones	9.8
Rear Seat Entertainment	9.9
Troubleshooting	9.10

Introduction

The Rear Seat Entertainment (RSE) system consists of two screens (mounted in the rear of the front seat head restraints) an infotainment menu system, a six DVD or CD player, audio headphones and a remote control. The rear seat passengers can watch or listen to separate programmes or audio on each screen.

The player will play 12 cm DVDs, Video CDs (VCDs) and audio CDs. The player is not compatible with High Definition DVD discs, DVD-ROMs, DVD-RAMs, Photo CDs or MP3.

 *Video CDs will have less options available from their menus.*

Headphones

Audio for the RSE can be delivered to the rear seat passengers via infra red (cordless) headphones. Volume is controlled from the headphones.

Regional Coding

Both the DVD player and DVD discs are coded by region. These regional codes must match in order for the disc to play. If the codes do not match, the disc will not play. Other regional codes cannot be played in this unit. The unit will show REGION CODE VIOLATION.

Safety Information

 **Warning: The screen glass on the LCD display may break when hit with a hard surface. If the glass breaks, do not touch the liquid crystalline material. In case of contact with skin, wash immediately with soap and water.**

- Read all of the safety and operating instructions before operating the RSE.
- Do not expose the LCD screen to direct sunlight or intensive ultraviolet rays for extensive periods of time. Ultraviolet rays deteriorate the liquid crystal.
- Carefully place any cords or cables where they will not be stepped on or interfere with the operation of seats or compartments.
- Do not insert foreign objects into the disc player.
- Do not clean any part of the disc player with solvents.

Disc Player Magazine

 **Do not leave the disc player door in the open position. If dirt or moisture enter the player this can reduce playback quality, and can result in damage to the player.**

The player is located behind the right hand wall trim panel in the boot. To load or eject a disc:

1. Slide the player door fully open and press the **EJECT** button.
2. Remove the magazine and put in or eject a disc(s) into, with the label side facing upwards, or out of the magazine.
3. Place the magazine into the player and fully close the sliding door.

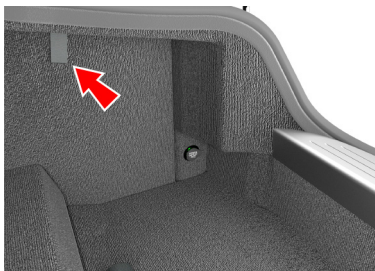

- Do not place any device or object that emits a magnetic field near to the player.
- Do not put in any object other than the recommended discs into the player for any reason.
- Make sure that the discs are clean and dust free before inserting into the player.

 *This product incorporates copyright protection technology that is protected by method claims of certain US patents and other intellectual property rights owned by Macrovision Corporation and other rights owners. Use of this copyright protection technology must be authorised by Macrovision Corporation, and is intended for home and other limited viewing uses only unless otherwise authorised by Macrovision Corporation. Reverse engineering or disassembly is prohibited.*

Federal Communication Commission (FCC) Compliance

Changes or modifications not approved by Aston Martin could void user's authority to operate the equipment. This equipment has been tested and found to comply with the limits for a Class B digital device, pursuant to Part 15 of the FCC Rules. These limits are designed to provide reasonable protection against harmful interference in a residential installation. This equipment generates, uses and can radiate radio frequency energy and, if not installed and used in accordance with the instructions, may cause harmful interference and radio communications.

However, there is no guarantee that interference will not occur in a particular installation. If this equipment does cause harmful interference to radio or television reception, which can be determined by turning the equipment off and on, the user is encouraged to consult the dealer or an experienced radio / TV technician for help.

Supervisory Control

⚠ The driver should make adjustments only when it is safe to do so. Driver distraction can lead to accidents causing serious injury or death.

Supervisory control of the RSE system is from the infotainment menu system. The RSE system, remote control and each rear screen can be set to ON or OFF using the infotainment menu system. Each screen is set and controlled independently.

When the RSE menu is selected in the infotainment centre audio menu the remote control is locked. The rear screen system settings are adjusted using the remote control.

From the AUDIO menu, select the <CD/RSE> option. Push the **JOYSTICK** down to access the RSE menu.



The following can be set to ON or OFF:

Left Screen on/off: Press **ENTER** to turn the left screen ON or OFF.

Right Screen on/off: Press **ENTER** to turn the right screen ON or OFF.

Remote Control Lock: Select from <Never Disabled>, <Disabled when in DVD Menu> or <Always disabled>.

Front DVD Audio: Press **ENTER** to select if DVD audio is played through the front speakers..

DVD Selection: Select a disc to play.

📖 Only one DVD can be viewed at a time on any screens.

Audio

When the audio source is selected, the rear passengers can listen to the vehicle audio system through the headphones. The rear passengers can not change any settings and only have control over the volume level using the headphones.

Any change to the audio source settings, for example changing tracks, must be completed through the infotainment centre. When the driver or front passenger has made changes to the audio source selected for the RSE they can return to their audio choice through the infotainment centre.

Rear Passenger Control

The rear seat passengers can operate the RSE system by using the remote control. Separate display modes and media sources for each screen can be selected using the switch on the rear of the remote control to select left and right screens. All screen settings are adjusted with the remote control.

 Check that the remote is not disabled before use (Refer to 'Supervisory Control', page 9.4).

Remote Control

[1] SCREEN SWITCH: On the rear of the remote control. In the centre position the remote control is locked. Press to the left or right and press the **ON/OFF** button to set the left or right system to ON or OFF. Press down to set the screen OFF or ON.

 Only the screen is set to OFF, the audio signal continues unless another source is selected.



[2] ON/OFF: Press and release to for ON / OFF.

[3] ■: Press and release to pause. Press again to stop play.

[4] DISP.: Press cycle through the setup menus (Refer to 'System Settings', page 9.6).

[5] LEVEL SET: Press to raise or lower the set level

[6] DVD MENU: Shows the DVD menu.

[7] JOYSTICK: DVD menu control. Move left, right, up, or down to navigate the menu. Press to confirm selection.

[8] RTN: Press to return to the previous CD or DVD menu.

[9] AUXILIARY PLAY CONTROLS: Not used.

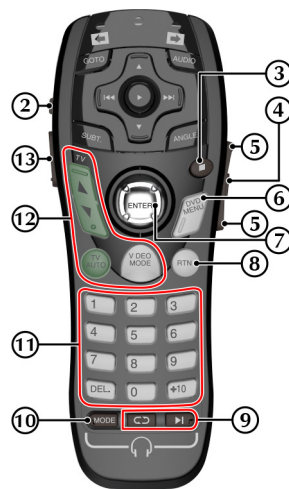

[10] MODE: DVD, CD, RSE audio selector.

[11] KEYPAD: Press to select DVD chapters or CD tracks.

[12] TV FUNCTIONS: Not used.

[13] LIGHT: Press to illuminate the controls.

[14] GOTO: Chapter selection and DVD status.

[15] ▲: Next disc up.

[16] AUDIO: DVD audio options.

[17] ►►: Seek forward and fast forward.

[18] ANGLE: DVD viewing angle options.

[19] ▼: Next disc down.

[20] ►: Play and pause.

[21] SUBT.: DVD subtitle options.

[22] ◀◀: Seek backward and fast backward.

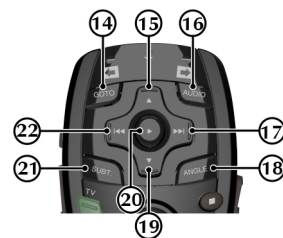

Remote Control Batteries

⚠ Warning: Used batteries must be disposed of correctly as they contain a number of harmful substances. Seek advice on disposal from your Aston Martin Dealer or your local authority.

To replace the batteries:.

1. Slide the battery cover off.
2. Remove the old batteries if required.
3. Install two 'AAA' batteries the correct way round (+ or -).
4. Slide the battery cover on.

 If the remote are not used for an extended period of time, remove the batteries to prevent damage.

To Set the RSE Screens ON and OFF

⚠ Always operate the engine during prolonged use of the RSE system. If the engine is not operating while the RSE is in use the vehicle battery can become discharged.

The RSE screens are only available with the vehicle key in at least in position 'I' and until the vehicle key is removed from the ignition control.

If the screen is set to OFF before the vehicle key is removed from the ignition control, the player will return to the same point in the movie when set to ON again.

 If the ignition is set to OFF but set back to position 'I' within 1 hour, the RSE system will ask if you want to resume from the point it was set to OFF.

When the RSE system and remote control have been set to ON using the front supervisory menu, move the **SCREEN SWITCH** on the back of the remote control to the left or right (left or right screen) and press the **ON/OFF** button to set the left or right screen to ON. Move the switch to the left or right and press the **ON/OFF** button for the second screen if required.

Press the **ON/OFF** button again to set each screen to OFF as required. The RSE screens default to OFF on each ignition OFF.

System Settings

Use the setup screen to configure the system and adjust the picture quality.

1. Press **DISP.** to access the first setting options. Press the button repeatedly to scroll through further options.
2. When the required option is highlighted the level can be adjusted or options can be selected. Use the **LEVEL SET** buttons to adjust the set level up or down or to make a selection.
3. Press the **DISP.** button again to exit the setup menu.

The setup screen will set to OFF after two second if no buttons are pressed.

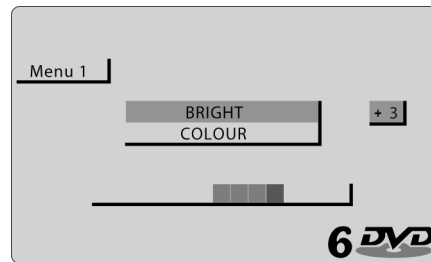

Menu options:

BRIGHT: Screen brightness.

COLOUR: Screen colour.

DIMMER (AUTO, DAY and NIGHT): Day is the brightest setting. Night is the lowest setting.

DIMMER LEVEL: Allows fine tuning of the day and night settings.

DISPLAY MODE: The screen aspect ratio can be adjusted to suit the video media being viewed. Press **ENTER** to confirm your selection.

[A] 16:9: Wide-screen.

[B] 4:3: Commonly used for TV.

[C] CINEMA: Used for films produced for cinema release.

[D] ZOOM: Slightly wider than Cinema setting.

NTSC/PAL: Select video playback format.

[A] AUTO: The system automatically selects the correct video format.

[B] NTSC (NATIONAL TELEVISION SYSTEM COMMITTEE): Format used in North America.

[C] PAL (PHASE ALTERNATING LINE): Format used in other countries around the world.

RESET DISPLAY SETTINGS: All on screen display settings will revert to their default settings.

RSE Media Source

DVD Play

To start DVD play, press **▶**. Press again to pause play (DVD still shows). Press again to resume play.

Press **■** to pre-stop play (DVD not shown). Press again to end play (DVD will start from the beginning).

To seek forward and backwards by chapters press **▶▶|** (forwards) and **◀◀** (backwards). For fast operation at x16 speed, press and hold.

To move to the next or previous disc press **▲** or **▼**.

 Play will start automatically when the next or previous disc is selected.

Press the **DVD MENU** button to access the DVD menu. Use the **JOYSTICK** to select an option and press **ENTER** to select. Press **DVD MENU** again to return to the DVD.

 A no entry symbol will appear in the top right corner of the display screen if a command is entered that is either not available either on the disc currently playing or at that time.

 The features available from the DVD menu will vary for each DVD. Refer to the instructions supplied on screen for more information.

DVD Special Features

Some DVD discs are recorded with additional features that allow subtitles to be displayed, camera angle to be changed and audio choices to be made. If these features are available they can be accessed with **DVD MENU** button. The dedicated feature buttons **GOTO**, **ANGLE**, **SUBT.** and **AUDIO** can be pressed to access the same features.

<GOTO>: Some DVDs offer title, chapter and time information. Press the **GOTO** button to scroll through the available options.

Use **GOTO** to access a point within the DVD programme, e.g. select chapter to show a chapter selection pop up. Use the **KEYPAD** to enter a chapter number (+10 and 6 = chapter 16) then press the **ENTER** button. A long press of the **GOTO** button will show the DVD status information. A second long press will show the previous screen.

<ANGLE>: Some DVDs offer alternative viewing angles in selected scenes. Press the **ANGLE** button to scroll through the available options.

<SUBT.>: Press the **SUBT.** button to scroll through the available options. Subtitles will show along the bottom of the screen. To set subtitles to OFF apply a long press of the **SUBT.** button.

<AUDIO>: Some DVDs have an alternative or extra sound feature such as a commentary. Press the **AUDIO** button to scroll through the available options. The selections appear as AUDIO 1 and AUDIO 2.

Audio CD Play

To start CD play, press ►. Press ■ to stop play.

To select the next track press ►► and to select a previous track press ◀◀◀. To fast forward or backwards press and hold.

To move to the next or previous disc press ▲ or ▼.

Press **DVD MENU** to access the CD menu. Use the **JOYSTICK** to select a track and press **ENTER** to select. Press **DVD MENU** again to return to the CD. If there is more than one page press the **JOYSTICK** left or right. Press **RTN** to view all music folders on the CD.

When playing an audio CD, press **DISPLAY** to show the current track playing, the total playing time of the track, the total playing time of the disc and the elapsed time of the track.

Headphones

⚠ Warning: Always store headphones safely when not in use. Do not leave them unsecured as they can cause injury in the event of sudden braking or an impact.

The RSE system includes a built-in infrared transmitter for use with wireless headphones. Adjust the volume by using the controls on each headset.

The wireless headphones must be used within a line of sight from the transmitter. Refer to the manufacturer's instructions accompanying the wireless headphones.

Using the headphones:

1. Press the **ON/OFF** button. The **POWER** LED will come ON.
2. Adjust the headphones for comfort: Hold an earpiece and pull out the headband with a smooth action. Do not use excessive force.
3. Select the channel to match the left or right screen. CH.1 is for the left screen and CH.2 is for the right screen.
4. Adjust the volume to suit.

 *The earpiece exteriors must remain exposed to the infra red transmitter in rear centre console. Any interference will prevent them from working correctly.*

When not in use set the headphones to OFF to save battery power. The headphones will automatically set to OFF after three minutes if they have not received an infrared audio signal.

Headphone Batteries

 **Warning: Used batteries must be disposed of correctly as they contain a number of harmful substances. Seek advice on disposal from your Aston Martin Dealer or your local authority.**

When the batteries require replacement the sound quality and volume will be compromised.

1. Slide the battery cover off.
2. Remove the old batteries if required.
3. Install two 'AAA' batteries the correct way round (+ or -).
4. Slide the battery cover on.

 *If the headphones are not used for an extended period of time, remove the batteries to prevent damage.*

Operating Tips

- When the engine is not operating, use the system sparingly otherwise it will drain the battery.
- When the ignition is set to OFF, the RSE is also OFF.
- The disc player is only capable of reading the bottom side of a disc. When inserting a single sided disc, ensure that the label is up. For a multi-sided disc, the desired play side should be down when the disc is inserted into the player.
- Disc players are designed to play commercially pressed 12 cm audio compact discs only. Due to technical incompatibility, certain recordable and re-recordable compact discs may not function correctly. Irregular shaped CDs, CDs with a scratch protection film attached, and CDs with home made paper (adhesive) labels should not be inserted into the disc player. The label may peel and cause the disc to become jammed. It is recommended that home made discs be identified with permanent felt tip marker rather than adhesive labels.
- The disc player is only capable of playback of DVD-Video and DVD-VR (DVD-R / DVD-RW) discs.
- Discs which are not finalised (processed to play on playback-only DVD players) cannot be played on this DVD changer.

- Some discs may not play back, depending on the recording device and disc format.
- Discs or files using copy protection, may not be playable. Some recording systems may not correctly format copied files to let correct playback.
- In the following cases, the disc may not play on this unit: discs recorded by certain DVD recorders, certain irregular discs, flawed discs, dirty discs, when the pickup lens of this DVD player is dirty, or when moisture condensation has occurred inside the unit.
- Be sure to follow all cautions included with your DVD-Rs / DVD-RWs / DVD+Rs / DVD+RWs discs.
- Compared to the regular discs, DVD-Rs / DVD-RWs / DVD+Rs / DVD+RWs are more affected by heat, moisture, and direct sunlight. If left in a car then damage may occur and it might not play on this unit.
- The operating temperature range for disc playback is as follows: DVD-R / DVD-RW: -25 ~ +70°C. DVD+R / DVD+RW: +5 ~ +55°C.

Troubleshooting

If it appears that the RSE system is not working correctly, first consult this checklist. Do not attempt to repair the system on your own as it will invalidate the warranty.

Look for the specific symptom(s) below. Only perform the action listed to remedy the specific symptom(s).

Remote Not Working

- Check that the batteries in the remote are working correctly.
- Check that the remote sensor eye is not obstructed.

Disc Will Not Play

- Check that the disc is inserted with the label side facing up.
- Check the type of disc you put into disc magazine.
- Both the unit and the disc are coded by region. If the regional codes don't match, the disc cannot be played.

Play Starts, But Then Stops

- The disc is dirty. Clean it.
- Condensation has formed. Allow the player to dry out.

No Sound or Distorted Sound

- Make sure the infra-red projector area (shown below) is not covered.



- Make sure that your unit is connected correctly. Make sure that all cables are securely inserted into the appropriate jacks.
- If you are using the headphones, make sure that the power to the headphones is ON.

- Make sure that the modulator is ON and the correct frequency has been selected.

Cannot Advance Through a Movie

You cannot advance through the opening credits and warning information that appears at the beginning of movies because the disc is programmed to prohibit that action. The feature or action cannot be completed at this time because:

- The disc's software restricts it.
- The disc's software does not support the feature (e.g., angles).
- The feature is not available at the moment.
- You've requested a title or chapter number that is out of range.

Picture is Distorted

- The disc might be damaged. Try another disc.
- It is normal for some distortion to appear during forward or reverse scan.

Hands-Free Phone

Introduction	10.2
Hands-Free Functions	10.2
Bluetooth Device Management	10.3
Using a Phone	10.4



Introduction

A mobile phone device equipped with Bluetooth® technology can be connected wirelessly to the vehicle's infotainment system, which allows control of a range of the mobile phone's functions. The mobile phone can always be operated by its own keys regardless of whether or not it is connected.

The hands-free system is available when the vehicle key is in ignition position 'I' or 'II'. If the ignition is moved to position '0' or removed, any calls will transfer to the mobile phone after approximately six seconds.

The system microphone is located in the vehicle roof above the drivers head and the speech from an incoming call is from the two door speakers.

 *The hands-free phone system uses the internal antenna of the mobile phone.*

Bluetooth Pairing

Before the hands-free system can be used, a phone must be 'paired' to the infotainment system (Refer to 'Bluetooth Pairing', page 6.5)

The hands-free phone system will not recognise a mobile phone, even if it was previously 'paired', if the mobile phone does not have the Bluetooth® wireless technology switched ON. For more information refer to the user's guide for your mobile phone.

Hands-Free Functions



[1] VOLUME: Volume control.

[2] ENTER: Press to answer or make a call, select in the menu or open a selection.

[3] **MENU:** Opens the main menu.

[4] **JOYSTICK:** Navigate in the menus, move forwards or backwards when entering text and digits.

[5] **DISPLAY:** Shows options, menus and information.

[6] **PHONE:** Press to access the phone menu.

[7] **BACK:** End a call, navigate back in the menu, cancel a selection or erase the previous character when entering text and numbers.

[8] **CALL:** Press to answer a call or press to return to hands-free mode from audio when hands-free mode is ON.

[9] **VOLUME:** Volume control during a call.

[10] **SCROLL:** Navigate in the menus.

[11] **CANCEL:** Press to end a call or press to enter audio mode when hands-free mode is selected.

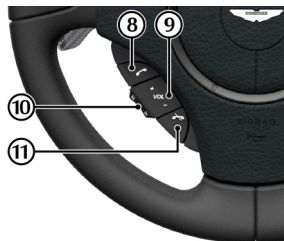

Audio Settings

Call Volume

During a call the call volume can be regulated using the **VOLUME** dial or the volume controls on the steering wheel.

Audio System Volume

All audio sources will be automatically muted for incoming calls

Bluetooth Device Management

Connecting and Disconnecting Devices

Once the infotainment system and a mobile device are paired (Refer to 'Bluetooth Pairing', page 6.5), the infotainment system automatically connects to the last connected mobile device when the ignition is set to ON₁.

To connect or disconnect additional paired mobile devices to or from the infotainment system, press **PHONE**, and navigate to <BT DEVICES>. Scroll through available devices and push the **JOYSTICK** right to access the device connection options. Select *Connect* to set the selected device as the active phone for calls and messages.

Only one device can have an active connection to the infotainment system. Connecting another device disconnects the previously connected device.

 *Disconnected devices are still stored in the infotainment system.*

¹. Bluetooth® wireless technology must be activate on the mobile phone



The vehicle will **automatically** disconnect the connected device when the ignition is switched OFF. Any active calls will be transferred back to the mobile phone.

Deleting a Device

The vehicle infotainment system supports paired links with up to 10 mobile devices. If additional devices are to be connected, one of the existing paired devices must be deleted.

To delete a device, select *Delete handset* from the device connection options.

Using a Phone

Contact List

The mobile phone's contact list is synchronised automatically to the vehicle system at each connection after initial pairing. All lists of calls and any new contacts that have been added since the mobile phone was last used with the vehicle's system are now updated. This may take a few seconds on initial connection.

 *If the mobile phone does not support synchronisation of the contact list then List is empty is shown after the mobile phone has been paired.*

 *Only one mobile device can have an active to the infotainment at any one time. Each contact list is only accessible when using the correct mobile phone.*

Contact Search

Contacts list and call history only apply to the connected mobile phone's phone book.

1.
 - Press **PHONE** or from the <Phone menu> select <PHONE CONTACTS>
 - Press **PHONE** or from the <Phone menu> select <CALL HISTORY>.
A list of relevant phone numbers and contact names is then shown.
2. Press the **JOYSTICK** (up or down) or turn the **JOYSTICK** dial to navigate to the contact.
If you rotate the **JOYSTICK** quickly, a fast scroll feature allows you to search through the phonebook alphabetically.

Making a Call

Check that the hands-free system is paired.

Press **PHONE** on the centre stack, or **CALL** on the steering wheel controls to view the call history list. Press **PHONE** again to view the menu.

- Select a contact to call from the . Press **CALL** or **ENTER** to call.

Or

- Navigate to the keypad. Rotate the **JOYSTICK** to cycle through numbers and **ENTER** to confirm a selection. Press the **JOYSTICK** left to delete a number. Press **CALL** or **ENTER** to call.

Ending Calls

To end a call press **CANCEL**.

Receiving Calls

To answer an incoming call press **CALL** or **ENTER**.

If the phone book contains a caller's contact information, this is shown.

Reject a Call

Press **CANCEL** while the phone is ringing.

Text Messages

The text message in the infotainment system is dependant on the mobile phone being used.

Text messages can be either displayed on the infotainment screen¹ or read aloud by the hands free system. For the vehicle to access phone messages, access must be allowed during initial pairing.²

When a new message is received, there are the following four options:

[A] LISTEN: Hear text message through the vehicle speaker system.

[B] MSG CENTRE: View messages on the infotainment display. New messages will have a red dot in the corner of the envelope symbol. (Not available if the vehicle is moving at more than 5 mph).

[C] CANCEL: Return to the *Phone Menu*.

[D] CONTACTS: View phone contacts.

You can also view any previously received messages. From the *Phone Menu* select *Messages* to view the message menu. Any unread messages are marked with a red dot.



ASTON MARTIN

¹ Messages are only available to read if the vehicle is stopped or travelling below 5 mph.

² iPhone users must manually set notifications to ON during initial pairing with the vehicle. If notifications are set to ON after pairing with the vehicle the phone will need to synchronise with the vehicle again.

Satellite Navigation

Important Safety and Product Information	11.2
Navigation Controls.....	11.2
Navigation Menu.....	11.3
Navigate.....	11.4
Map	11.6
Points of Interest (POI)	11.8
Traffic	11.9
Settings	11.10

Important Safety and Product Information

⚠ Warning: Failure to avoid the following potentially hazardous situations could result in an accident or collision resulting in death or serious injury.

⚠ Warning: Always use your best judgement, and operate the vehicle in a safe manner. Do not become distracted by the navigation system while driving, and always be fully aware of all driving conditions. Minimise the amount of time spent viewing the screen while driving and use voice prompts when possible.

⚠ Warning: Do not input destinations, change settings, or access any functions requiring prolonged use of the navigation system controls while driving. Bring the vehicle to a halt in a safe and legal manner before attempting such operations.

⚠ Warning: When navigating, carefully compare information shown on the screen to all available navigation sources, including road signs, road closures, road conditions, traffic congestion, weather conditions, and other factors that may affect safety while driving. For safety, always resolve any discrepancies before continuing navigation, and defer to posted road signs and road conditions.

⚠ Warning: The navigation software is designed to provide route suggestions. It is not a replacement for driver attentiveness and good judgement. Do not follow route suggestions if they suggest an unsafe or illegal manoeuvre or would place the vehicle in an unsafe situation.

Navigation Controls

Operation

The navigation system is available with the vehicle key in position 'I' or 'II'.

Press **NAV** on the centre stack, or select the Navigation icon and press **ENTER** if already in the Infotainment menu.



Navigation Menu

[1] SCREEN: Shows maps and provides detailed information on route type, distance, etc.

[2] BACK: Press to return to the previous menu or to undo a choice.

[3] NAV: Press to open the *Map* screen (Refer to 'Map', page 11.6).

A second press will open the *Navigation Menu* screen (Refer to 'Navigation Menu', page 11.3).

[4] JOYSTICK: Navigate through different menu options, traffic messages, etc.

Rotate to zoom the map in or out.

[5] ENTER: Press to confirm, select or navigate from one submenu to the next submenu.



The Navigation menu opens with several options available:

[1] DESTINATION COUNTRY: To change the destination country, rotate the **JOYSTICK** to cycle through letters and press **ENTER** to confirm a selection.

To delete a character, push the **JOYSTICK** to the left.

[2] NAVIGATE: (Refer to 'Navigate', page 11.4)

[3] POI: (Refer to 'Points of Interest (POI)', page 11.8)

[4] DISPLAY MAP: (Refer to 'Map', page 11.6)

[5] CANCEL NAVIGATION: Press to cancel the navigation route (if one is set).

[6] GPS: Shows satellite information such as available number of satellites and signal quality

Address Entry

The a destination can be set one of two ways in the **Navigate** menu:

- Address Entry
- Recent Addresses

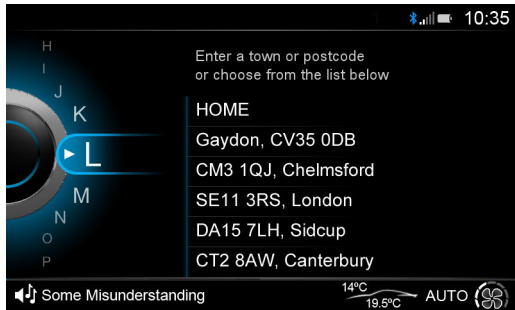

Address Entry

Rotate the **JOYSTICK** to cycle through letters and numbers and press **ENTER** to confirm a selection. The address list will show available addresses from the characters entered.

Once a letter or number has been selected, only the characters that follow in any available matches will be selectable.

To delete a character, push the **JOYSTICK** to the left.



 A street name cannot be selected until a town or city has been set.

 A street name cannot be entered if a 7 character post code is entered.

Push the **JOYSTICK** to the right to access the address list along with a map showing each address location.



Recent Address

To select a HOME, WORK or recent destinations¹, press the **JOYSTICK** right to access the address list along with a map showing each address location. Rotate the **JOYSTICK** to scroll available addresses and press **ENTER** to select an destination.

¹. HOME and WORK addresses are only shown once they have a saved address.

Destination Selection Options

Press **ENTER** on an entry in the address list to open the options below:

- Navigate to here
Opens the map screen and calculates a route.
- Enter Street/Enter Building Number
Opens the address entry screen to further refine the destination location.
- Near to Here
Opens the Destination POI screen with the origin point set to the current selection. (For example, Chelmsford).
- Save as HOME
Saves the selected destination as your *HOME* address.
- Save as WORK
Saves the selected destination as your *WORK* address.



Guidance Start

If *Alternative Routes* has been set to ON in the navigation settings menu, three routes will be calculated in order of quickest time. Each will show total distance and arrival time with an overview of the proposed route.

Rotate the **JOYSTICK** and press **ENTER** to select a route.



Map

Map Controls

Push the **JOYSTICK** up or down to display the map view menu.

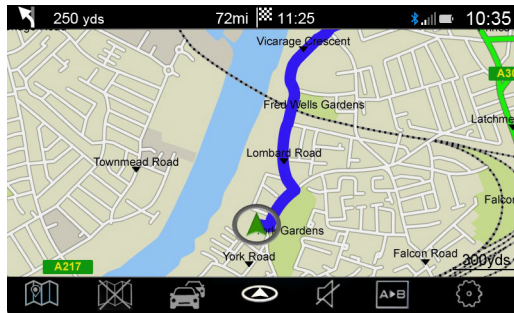

[1] **NAVIGATION:** Opens the **Address Entry** screen.

[2] **CANCEL ROUTE:** Cancel the selected route.

[3] **TRAFFIC:** Open the **Traffic** screen.

[4] **HEADING ORIENTATION:** Press to cycle between:

- 2D North
2 dimensional map with north always at the top of the screen.
- 2D Heading
2 dimensional map with the vehicles direction always at the top of the screen.
- 3D heading
3 dimensional map with the vehicles direction always at the top of the screen.

[5] **VOICE MUTE:** Set voice instructions on or off.

[6] **ROUTE OVERVIEW:** Shows an overview of the navigation route.

[7] **SETTINGS:** Open the Settings menu

Map Zoom

Rotate the **JOYSTICK** clockwise to zoom in and counter-clockwise to zoom out of the map.



Map Browse

Press and hold **ENTER** to enable browse map.

Information Bars

Press **ENTER** to cycle if the upper and lower information bars are shown.

Estimated time of arrival (ETA) will be shown at the top of the screen.

Next Turn

If there is an approaching turn, the distance and street name are shown at the top of the screen.

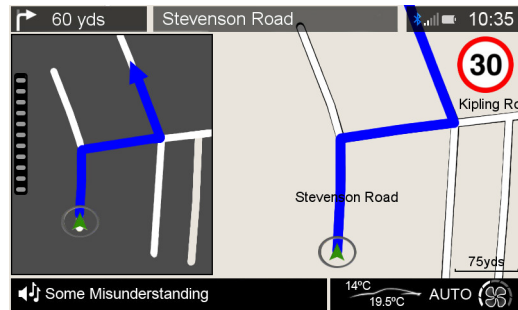

Push the **JOYSTICK** left or right to cycle if the turn information window is shown.

The turn information window will show a view of the next turn or junction and the gauge on the left illuminates as you approach the junction.

Browse Map

Whilst in map browse, press and hold **ENTER** to open the browse map function, and push the **JOYSTICK** up, down, left or right to move the cursor around the map.

Press **ENTER** to place a marker on the cursor position. This will open the POI window and allow you to search for locations in the area chosen.

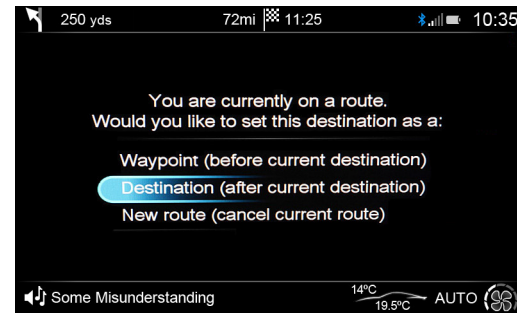

Points of Interest (POI)

Press **BACK** to cancel the set marker window and return to the map browse screen.

Press **BACK** to move the cursor back to the vehicle. Press **BACK** again or press and hold **ENTER** to return to the **Map** screen.

Rotate the **JOYSTICK** to cycle through letters and numbers and press **ENTER** to confirm a selection.

Once a location name or partial name has been entered, push the **JOYSTICK** to the right to access the category list. Scroll and select a category to search.

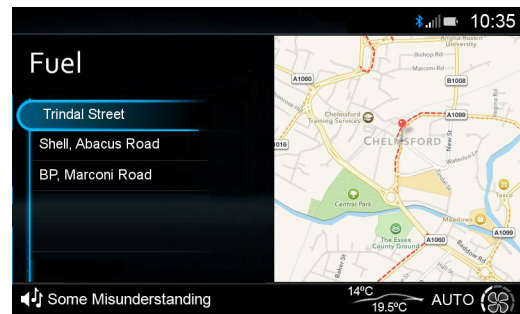
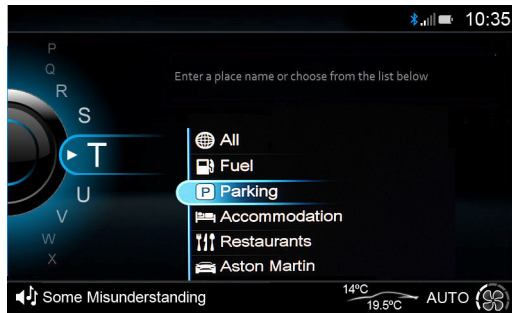

The results list will then show a list of available POIs in distance order within that category and a map to show location. The map will update to centre on the selected result from the results list.

Traffic

POIs on Route

If a route is already set, you will have additional options when opening the POI menu:

- Waypoint
Adds POI into the set route.
- Destination
Adds POI as a destination after the set route.
- New Route
Cancel the set route and set a new destination.

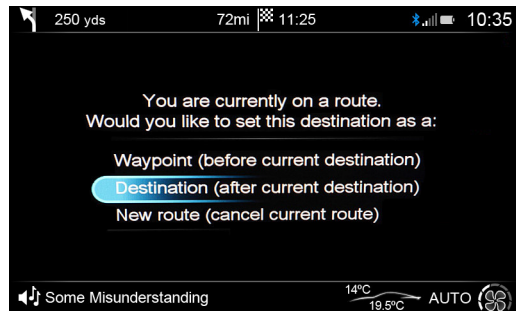

The *Traffic* screen shows delays on a selected navigation route. Any delays will be shown as time delays in hours and minutes.

All Delays On Route

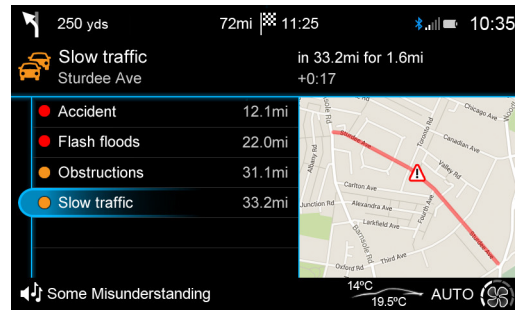

Any delays on the selected route will be shown, along with how far along the route each individual delay is. The top traffic information bar will also describe:

- The type of delay,
- The road the delay is on,
- How far away the delay is,
- How long the delay is in distance,
- The time added to your journey.

Delays are also shown by their severity.

Green: Traffic is moving freely - Low severity

Orange: Traffic is moving but with some congestion - Medium severity

Red: Traffic is not moving or is moving slowly - High severity

Settings

Map Settings

 Navigation settings are also accessed from the vehicle settings menu.

Map Orientation

Select from:

- 2D North
2 dimensional map with north always at the top of the screen.
- 2D Heading
2 dimensional map with the vehicles direction always at the top of the screen.
- 3D Perspective
3 dimensional view of 2D Heading.

Display Mode

Select from:

- Auto
Automatically change between *Day* and *Night* mode.
- Day
Set the display to use brighter colours suitable for daytime driving.
- Night
Set the display to use darker colours to reduce glare from the navigation screen when driving at night.

Show POIs on Map

Set whether to show Points of Interest (POIs) on the map.

Show Landmarks on Map

Set whether to show landmarks on the map.

Show 3D Buildings

Set whether to show buildings on the map.

Satellite Images

Set whether to show satellite images on the map.

Automatic Zoom

Set whether to automatically zoom in and out of the map depending on speed and distance to junctions.

Navigation Options

Voice Prompts

Sets voice announcements ON or OFF.

Voice Language

Sets the language for voice announcements¹ (Final List TBD)

Street Names

Set to add street names on map.

Alternative Routes

Set whether alternative routes are offered when a destination is selected.

¹ Navigation language can be set independently of infotainment system language.

Avoid Options

Select features to avoid when calculating navigation routes. Select the following check-boxes:

- Avoid Motorways
- Avoid Toll Roads
- Avoid Ferries
- Avoid Motorail Trains
- Avoid Tunnels
- Avoid Unpaved Roads
- Avoid Car Pool Lanes

Speed Limits

Show current speed limit on map.

Re-routing

Allow automatic re-routing.

Restore to Default***Clear Recent***

Clear recent address, HOME and WORK history.

Reset All

Restore all navigation settings to default



ASTON MARTIN



ASTON MARTIN



ASTON MARTIN



ASTON MARTIN

Maintenance

Introduction	12.2	Tyres	12.12	Other External Lamps	12.25
Vehicle Jacking	12.3	Winter Tyres	12.14	Boot Lamps	12.25
Servicing Precautions	12.3	Tyre Sealant Kit	12.14	Internal Lamps	12.26
Emergency Items	12.5	Vehicle Recovery	12.16	Tourist Headlamp Adjustment	12.26
Owner Maintenance	12.5	Vehicle Battery	12.18	Door Window Reset	12.27
Bonnet Release	12.7	Vehicle Battery Charge	12.19	Front Seat Reset	12.27
Fluid Levels	12.8	Battery Protection Mode	12.20	Bodywork Maintenance	12.28
Windscreen Blade Replacement	12.11	Fuse Boxes	12.22	Vehicle Cleaning	12.28
Brake Pad Bedding-in	12.12	Headlamp	12.25	Vehicle Storage	12.31



Introduction

Each item in the service schedules must be performed on time as failure to do so may void the new vehicle warranty or other warranties. It is the owner's responsibility to see that the vehicle is maintained correctly and in accordance with the manufacturer's service schedules.

Due to the sophistication of the various systems and the specialised equipment required to maintain this vehicle, owner maintenance should be restricted to the routine procedures described in this owner's guide.

If you think that this vehicle is not functioning correctly, please return it to an Aston Martin Dealer to be checked professionally.

Restraint Systems

Aston Martin recommend that the inflatable (airbags) restraint systems and seat belt components installed to this vehicle are replaced at 10 year intervals from the date of manufacture on the certification label.

Electronic Fuel Injection

⚠ Warning: If the fuel system is allowed to run dry, irreparable damage to the fuel pumps may occur.

⚠ Warning: Any modifications or additions to the fuel system not specifically designed by Aston Martin are prohibited. If carried out, they may cause damage to the fuel system which in some circumstances could result in fire. All Service Action and Safety Recall Campaigns must be undertaken by an Aston Martin Dealer.

The electronic fuel injection system requires special equipment and test facilities to set up and maintain so that the vehicle gives maximum performance coupled with economy, reliability and safe vehicle emissions. You are, therefore, strongly advised to entrust all service work to an Aston Martin Dealer.

Parts and Lubricants

Aston Martin recommends that when performing a servicing task, the recommended lubricants (Refer to 'Fluids and Capacities', page 13.3) and parts are used

⚠ If oils or lubricants are used which do not meet the required specification, vehicle components may experience excessive wear, a build-up of sludge and deposits or cause increased pollution. If it is evident to Aston Martin that use of products other than those which are recommended by the manufacturer has caused damage to the vehicle or engine, Aston Martin may refuse to authorise the repair of such damage under the terms of the manufacturer's warranty.

Vehicle Jacking

⚠ Warning: Make sure that no persons are in the vehicle before jacking commences.

⚠ Warning: Make sure that the park brake is ON and that the vehicle transmission is in Park (P).

⚠ Warning: Make sure that the vehicle is parked on firm and level ground to give a secure base for the jack.

⚠ Do not raise the vehicle by placing a vehicle jack under the suspension arms.

If this vehicle is to be raised using a vehicle jack make sure that the following jacking points are used.

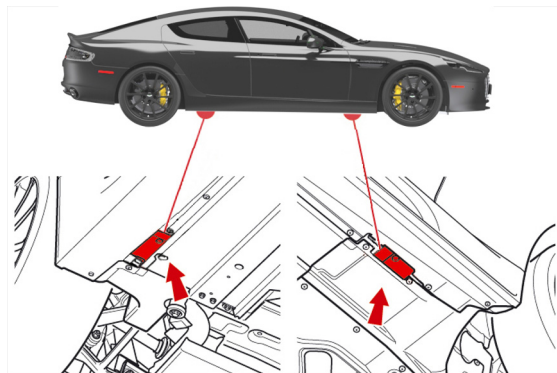

Servicing Precautions

To avoid personal injury, the following safety precautions must be observed when the bonnet is open and the engine is operating or the ignition is ON.

⚠ Warning: Protect yourself against dangerous substances .

⚠ Warning: Keep hands, hair, tools, items of clothing and jewellery clear of all drive belts, pulleys and operating mechanisms. The cooling fans may operate even though the engine is not operating.

⚠ Warning: Avoid skin contact with all exhaust system and engine components, engine fluids and escaping steam. They may be hot and can cause scalding or burns.

⚠ Warning: Do not breathe exhaust fumes. Exhaust fumes contain carbon monoxide. Carbon monoxide is a dangerous gas, which is colourless and odourless and can cause unconsciousness and may be fatal. Never start or leave the engine running in an enclosed, unventilated area.

⚠ Warning: Do not work beneath the vehicle with a vehicle lifting jack as the only support. Place suitable stands under the vehicle.

⚠ Warning: Keep children and pets clear of the vehicle. Do not let anyone inside the vehicle unless specifically working to your instructions.

⚠ Warning: Whenever possible, work in the engine compartment with the engine cool, the ignition OFF and the vehicle battery disconnected.

⚠ Warning: Petrol is highly flammable and, in confined spaces, is also explosive and toxic. In the event of spillage, set the engine to OFF. Do not use a flame or spark near fuel or fuel vapour. Do not smoke near fuel or fuel vapour. Do not inhale fuel vapour or fumes.

Dangerous Substances

⚠ Warning: Dangerous substances should be kept out of reach of children.

⚠ Warning: Many liquids and other substances used in motor vehicles are poisonous and should under no circumstances be consumed and should, so far as possible, be kept from contact with the skin. These substances include battery electrolyte, antifreeze, oil, brake and clutch fluid, petrol, windscreen washer additives, lubricants, refrigerant and various adhesives.

⚠ Warning: Particular care should be taken to avoid unnecessary contact with used engine oil. Always read carefully the instructions printed on labels or stamped on components and follow them carefully. Such instructions are included for reasons of your health and personal safety. Never disregard them.

Engine Oils

⚠ Warning: Prolonged and repeated contact with used engine oils can cause serious skin disorders, including dermatitis and cancer. Avoid excessive contact, wash thoroughly after contact. Keep out of reach of children. When your oil is changed, be sure that it is done by an experienced person. In addition, observe all laws regarding the disposal of waste oil and toxic fluids.

Protect The Environment

⚠ Warning: It is illegal to pollute drains, water courses, or soil. Use authorised waste disposal facilities, including civic amenity sites and garages providing facilities for receipt of used oil. If in doubt, contact your local authority for advice.

Emergency Items

The following emergency items are located in the boot.

[1] : Tyre Sealant Kit (Refer to 'Tyre Sealant Kit', page 12.14).

⚠ Always follow local regulations when placing a warning triangle.

[2] : Warning Triangle.

[3] : Towing eye, located in the vehicle tool kit.

[4] : First Aid Kit, located behind the left side trim panel (optional item).

Owner Maintenance

In the interests of safety and reliability, it is advisable to carry out the following checks at the intervals suggested (more frequently if your vehicle is heavily used or operating in adverse conditions), and always before starting on a long journey. Refer to the following pages for advice and check procedures.

Before Use Check:

- Operation of lamps, horn, indicators, wipers, washers and warning symbols
- Check there is sufficient fuel for the intended journey, particularly at night and before entering motorways
- Operation of the seat belts
- Operation of the brakes
- Check for fluid deposits underneath the vehicle.

Weekly Checks

(daily if covering high mileage or touring)

- Tyres
- Coolant level
- Brake fluid level
- Power steering level
- Operate air conditioning
- Windscreen washer fluid level
- Check operation of windscreen washers.

Fuel Filler Bowl

During fuel filling check that the fuel filler bowl drain pipe is free from debris which may block the pipe. If the pipe is blocked water can not drain from the bowl and can overflow into the fuel tank.

Engine Oil Level

! *It is important to check the engine oil level regularly. Running the engine with engine oil below the lower mark or above the upper mark can cause serious engine damage.*

Check the engine oil level every fourth fuel tank fill or weekly - whichever ever is the sooner.

Tool Kit

A vehicle tool kit is located under the trim panel in the boot floor. Pull up on the left or right side corner of the trim carpet to lift the panel (A).

The tool kit consists of:

- Towing eye (Refer to 'Vehicle Recovery', page 12.16)
- Emergency fuel fill funnel
- Road wheel lock nut socket (optional)

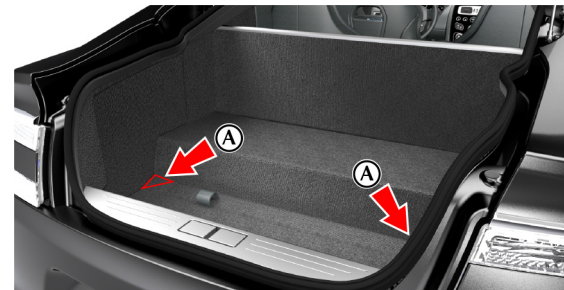

Battery Conditioner

A battery conditioner is located in the boot storage area. This is an optional item.

(Refer to 'Battery Conditioner', page 12.19)

Bonnet Release

⚠ Warning: The two secondary latches on the bonnet are sharp. Take care to avoid personal injury when under the bonnet.

⚠ Do not press down hard on the bonnet if it has not closed correctly. This may damage the bonnet.

⚠ Take care to not unintentionally pull on or catch the bonnet release lever.

⚠ Warning: Do not pull on the bonnet secondary catch to close the bonnet. This may displace the bonnet secondary catch and cause it to not align correctly.

📖 The windscreen wipers will temporarily rest in the park position if the bonnet is unlatched.

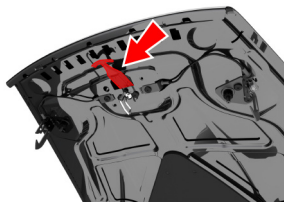
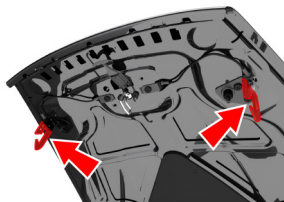

📖 Remove any tools, cleaning cloths, etc. from the engine compartment before closing the bonnet. Make sure that no one is obstructing the 'closing' area and that hands, clothing etc. are clear.

📖 If the bonnet does not fully close or it opens during driving, the message centre will show BONNET OPEN.

Pull the bonnet release lever (A) located in the left front footwell. The bonnet will release, but stay secured by the bonnet secondary catch.

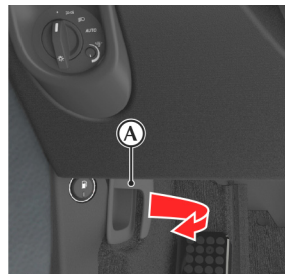

Slightly lift the front edge of the bonnet whilst pulling upward on the bonnet secondary catch (B) to release it. Lift the bonnet until fully open. Lift the bonnet until fully open. The bonnet is held open by two gas struts.

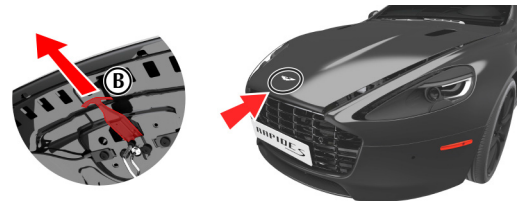

To close the bonnet, lower the bonnet until it starts to fall under its own weight and allow it to close.

If the bonnet does not shut, open and close the bonnet again, but gently push down as the bonnet falls.

Fluid Levels

⚠ Warning: Engine components may be hot and could cause severe burns.

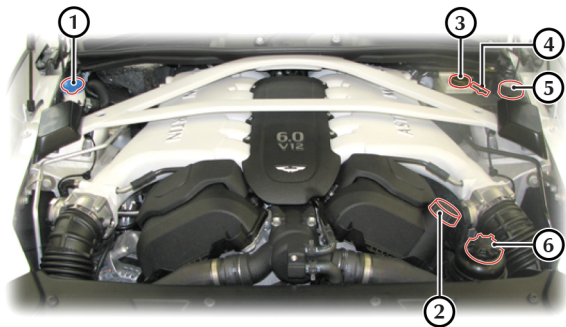

- [1] : Washer fluid reservoir.
- [2] : Engine oil filler cap.
- [3] : Brake fluid reservoir¹.
- [4] : Engine oil dipstick.
- [5] : Engine coolant reservoir.
- [6] : Power steering fluid reservoir.

¹. Changes sides for left and right hand drive.

Windscreen Wash Fluid Level

Top up as required. Increase the fluid concentration in winter to prevent the windscreen wash fluid (refer to the manufacturers recommendations on the windscreen wash fluid container).



When the windscreen wash fluid is low a warning message will show in the message centre and an amber warning symbol will come ON.

Local or state regulations may restrict the use of volatile organic compounds (VOCs), which are commonly used as antifreeze agents in windscreen washer fluid. A windscreen washer fluid with limited VOC content should be used only if it provides adequate freeze resistance for all regions and climates in which the vehicle will be operated.

Windscreen Washer Jets

The washer jets are located on the rear edge of the bonnet.

If adjustment is required, adjust so that the fluid strikes between a third and half way up the windscreen.

Brake Fluid Level

⚠ Warning: Do not drive the vehicle if the brake fluid level is below the minimum mark.

⚠ Make sure that the brake fluid does not contact the paint work during the topping up operation. Serious paint work damage can result. If a spillage does occur, immediately flush any brake fluid from the paint work with clean, fresh water and then wipe with a clean damp cloth.

The brake fluid level should read between the Min. and Max. marks.

1. Remove the reservoir cap. Top up to the Max. level.
2. Install the reservoir cap securely.



Engine Coolant Level

⚠ Warning: Do not remove the filler cap until the coolant system has cooled. Scalding can be caused by escaping steam or coolant.

 Use a cloth or glove to protect hands and protect face and arms adequately.

1. Remove the pressure cap to check the coolant level. The correct coolant level is to the top of the reservoir tank. Top up with the correct antifreeze mix, if required (Refer to 'Fluids and Capacities', page 13.3).
2. Make sure that the filler cap is secure after topping up.

⚠ Do not over tighten.



Power Steering Fluid Level

⚠ Make sure that the power steering fluid does not contact the paint work during topping up. Serious paint work damage can result. If a spillage does occur, immediately flush any power steering fluid from the paint work with clean fresh water, then wipe with a clean damp cloth.

Always check the reservoir level when the engine is cold and with the front road wheels in the straight ahead position.

Wipe the reservoir cap clean before removing to prevent an ingress of contaminants.

1. Remove the reservoir cap and wipe the dipstick clean with a lint free cloth. Replace and remove again. The fluid level should read between the Min. and Max. marks.
2. If required, top up fluid level. **Do not overfill.**



Engine Oil Level

⚠ Warning: Engine oil or components may be hot and could cause severe burns.

! Running the engine with engine oil below the lower mark or above the upper mark can cause serious engine damage.

! This vehicle's warranty may be invalidated if damage is caused by the use of incorrect engine oil. Low quality or obsolete oils do NOT give the protection required by modern, high performance engines.

! Failure to use engine oil that meets the required specification could cause excessive engine wear, a build up of sludge and deposits, and increased pollution. It could also lead to engine failure (Refer to 'Fluids and Capacities', page 13.3).

Engine Oil Level Check:

- The vehicle should be on level ground.
 - Check the engine oil level every fourth fuel tank fill or weekly - whichever ever is the sooner.
 - The engine should be cold
1. If the vehicle has been driven recently, run the engine until it reaches normal operating temperature.
 2. Wait 10 minutes to allow to engine oil level to become stable
 3. Withdraw and wipe the dipstick clean using a lint free cloth.



4. Fully insert the dipstick into the dipstick tube with the Min. and Max. marking on the blade upwards (facing towards the engine). Withdraw the dipstick again.



Windscreen Blade Replacement

- The engine oil level should read between the Min. and Max. marks.

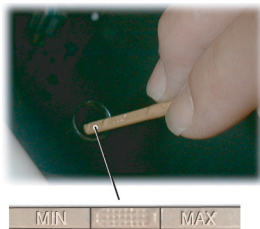

- Put the dipstick back into the dipstick tube.
- If required, remove the engine oil filler cap and top up the engine oil with the recommended engine oil.

 *Approximately two litres are required to bring the oil level from Min. to Max.*

- Wait for approximately two minutes for the engine oil to settle, then repeat steps 3 to 6 . Add engine oil if required. **Do not overfill.**
- Securely refit the engine oil filler cap.

To replace the windscreen wiper blades, the vehicle must be in wiper service mode.

Set the ignition to position 'I' (ignition OFF and accessories ON). From the Infotainment system, select <SYSTEM SETTINGS> **ENTER** <Wiper service> **ENTER**. Pressing **ENTER** then enables the wiper service mode.

Set the ignition to position 'II' (ignition ON). This moves the wiper blade arms to the 90° position. Set the ignition to position '0'.

Lift the wiper arm(s) up, press at point (B) and remove the worn wiper blade(s). Install the new wiper blade(s) and lower the wiper arm(s).

After replacing the wiper blade either:

- Move the vehicle key back through to position 'II' to lower the wiper arms. Return the vehicle key to position '0' or remove.
- Operate the wiper stalk - the wiper arms will complete the request and then park.

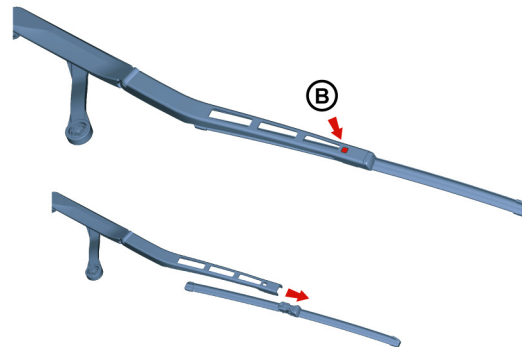

Brake Pad Bedding-in

⚠ Failure to bed-in new brake pads will result in reduced brake performance and possible brake judder or squeal.

After the installation of new brake pads, brake performance will be reduced, as the brake discs and pads need to be 'bedded-in'. For the first few hundred kilometres of new brake pad use, avoid excessive braking (hard stops from high speed, alpine descents, etc.).

Tyres

Tyres of the correct type, manufacturer and dimensions, with correct cold inflation pressures are an integral part of every vehicle's design. Regular maintenance of tyres contributes not only to safety, but to the designed function of the vehicle.

Road holding, steering and braking are especially vulnerable to incorrectly pressurised, badly installed or worn tyres.

Tyres of the correct size and type, but made by different manufacturers can have widely varying characteristics. Only install tyres approved by Aston Martin.

Tyre Pressures

Make sure that correct tyre pressures are carefully maintained. Road holding, steering, braking and tyre wear are especially vulnerable to incorrect tyre pressures.

Check tyre pressures regularly and before starting any journey, and adjust accordingly.

Tyre pressures increase slightly when the tyres are hot. For an accurate reading, tyre pressures should be checked when the tyres are cold. After adjusting the tyre pressures, make sure that the valve caps are securely replaced to provide an additional air seal and to prevent the ingress of dirt.

Tyre Service

 Because of the high performance potential of this vehicle, Aston Martin strongly recommend replacement of any damaged or worn tyre.

The recommended tyres for this vehicle are asymmetrical and must be installed to the wheel with the tyre mark 'OUTSIDE' on the outside of the wheel rim.

The tyres are also of different sizes on the front and rear axles, therefore complete wheels cannot be swapped between axles. Complete wheels can, however, be swapped from side to side on the same axle.

Damage

Tyres should be examined at regular intervals for wear and damage. Inspect the tyre treads and sidewalls for damage, i.e. bulges in the tread or the sidewalls, cracks in the tread groove and separation in the tread or the sidewalls. If damage is observed or suspected have the tyre inspected by a tyre professional.

Stones or other objects which have become lodged in the tyre treads should be carefully removed.

Flat Spots

It is a characteristic of high performance tyres that temporary 'flat spots' may develop if the vehicle is left standing in high or low ambient temperatures for any length of time.

These 'flat spots' will manifest themselves as minor vibrations when the vehicle is first driven from cold. As the tyres warm up to operating temperature, normal tyre shape should be restored and the vibrations cease. If vibrations persist, consult your Aston Martin Dealer.

Age

 *Local regulations on tyre life may apply.*

Tyres degrade over time, even when they are not being used. It is recommended that tyres generally be replaced after six years of normal service. Heat caused by hot climates or frequent high loading conditions can accelerate the aging process.

New Tyres

When new tyres are required consult your Aston Martin Dealer for advice if the rear tyres are also worn. Each wheel and tyre unit must be balanced dynamically and measured for Radial Force Variation (RFV) to make sure of efficient steering, optimum tyre wear and maximum ride comfort. Because of the potentially high speeds, it is essential that wheel balancing is carried out when new tyres are installed. Contact your Aston Martin Dealer for more information.

Running-In New Tyres

When new tyres have been installed, speed should be limited, particularly during the first 80 km or so of driving. Fast cornering, hard braking, and harsh acceleration should also be avoided during this period.

Tread Wear Marks

Tread wear marks (A) are incorporated into the construction of all tyres. These marks are integral moulded ribs spaced at regular intervals around the circumference of the tyre and extend across the full width of the tread, in all primary grooves.

When a tyre has worn causing one or more of the marks to be flush with the outer face of the tread the tyre has reached its wear limit. It then becomes illegal in certain countries and must be replaced.



Winter Tyres

The tyres installed as original equipment are designed with a rubber compound, tread pattern and width specially suited for high speeds in normal road conditions, but they are less suitable during extremes of low temperatures, snow and ice. The use of winter tyres will considerably improve handling during these conditions.

Only use Aston Martin approved winter tyres.

⚠ Warning: When winter tyres are fitted, the maximum speed limit of the vehicle could be reduced. Winter tyre speed limits and information should be provided upon installation of the winter tyres. Please consult your Aston Martin Dealer for more information.

Winter tyres must be used in vehicle sets, that is, installed on all four wheels. Do not exceed the tyre speed rating when using winter tyres.

Snow Traction Devices

⚠ Warning: The maximum speed when using snow traction devices is 48 km/h. Remove the snow traction devices immediately when the roads are clear of snow.

These are for temporary use when driving in heavy snow conditions. Snow traction devices should only be installed to the rear (driven) wheels. For more information regarding the correct snow traction device to fit to your vehicle, contact your Aston Martin Dealer.

Tyre Sealant Kit

⚠ Warning: Do not use the system to seal a tyre that was damaged while driving with insufficient air pressure (e.g. tyre cuts, cracks, bumps or similar damage). Do not use the system to seal tyres with side wall damage. Only punctures in the tread area of tyres may be sealed.

⚠ Warning: Do not stand directly beside the tyre while the compressor is pumping. Watch the side wall of the tyre. If there are any cracks, bumps or similar damage set the compressor to OFF. The journey should not be continued. Contact your nearest Aston Martin Dealer.

⚠ Warning: If a tyre pressure of 1.8 bar (26 Psi) cannot be reached then the tyre can not be sealed. Do not attempt to re-inflate the tyre. Contact your Aston Martin Dealer.

⚠ Warning: If the pressure in the tyre after driving for 3 km is below 1.3 bar (19 PSI) the tyre has not been effectively sealed. The journey should not be continued. Contact your nearest Aston Martin Dealer.

⚠ Warning: After a longer period of rest, the tyre pressure should be rechecked.

! *The tyre sealant kit only provides temporary mobility. Always refer to local laws and regulations on the use and repair of tyres that have been treated with any form of temporary mobility aid. Consult a tyre specialist for advice.*

 *Inform the tyre specialist that the tyre contains sealant.*

Location

The tyre sealant kit is located in the left side of the boot storage area.

Operation

Remove the tyre sealant kit from its location in the boot. Follow the instructions detailed on the lid.

Read the following instructions and warnings carefully before using the tyre sealant kit. Compliance with these instructions is vital to make sure of vehicle and user safety. Non-compliance with these instructions means risking severe tyre damage and hazardous vehicle behaviour which can lead to a road accident involving damage to property or injury to persons.

- Make sure that the vehicle is parked far enough from traffic so that there is no danger from passing vehicles and so that you do not disrupt the traffic. Warn other vehicles using the warning triangle.
 - The system should only be used between temperatures of – 40°C and 70°C.
 - A maximum speed of 80 km/h (50 mph) may not be exceeded at any time after sealing the tyre with the system.
 - The system provides only a **temporary emergency repair** for continuing the journey up to 200 km (125 miles) or to the nearest Aston Martin Dealer.
 - If the nearest Aston Martin Dealer is over 200 km (125 miles) away, arrange for collection with Aston Martin Assistance.
 - The system will effectively seal a tyre that was punctured by an object with a diameter of up to 6 mm. It is possible that a tyre, especially with greater damage, will not be sealed. Do not remove objects that punctured the tyre if they are still lodged in the tyre.
 - The sealant bottle needs to be exchanged before it expires. **Do not** use the system after the expiry date on the sealant bottle or casing has been reached. Contact your nearest Aston Martin Dealer.
 - Do not attempt to inflate other objects without using a system adapter and do not inflate objects with a volume greater than 50 litre (air mattresses, rubber boats, etc.). Do not let the system pump air for more than 10 minutes without stopping it and allowing it to cool down.
- Both the hose and the bottle of sealant need to be replaced after using the system. Sealant deposits in a used hose may cause the system to operate incorrectly. New bottles of sealant can be purchased from your Aston Martin Dealer.
- Dispose of empty sealant bottles together with normal household waste.
- Remains of liquid sealant must be handed over to your dealer or disposed of in compliance with local waste disposal regulations.

Vehicle Recovery

⚠ **When moving the vehicle by transporter make sure that the vehicle is not strapped down to the transporter by the suspension control arms.**

⚠ **Power braking and power steering are not available with the engine OFF. Substantially higher brake pedal pressures and steering effort are required.**

⚠ **If there is a transmission fault, this vehicle must be transported.**

If the park brake was applied and the vehicle has lost power, the park brake will not release. Call Aston Martin Assistance or your local Aston Martin Dealer.

Your vehicle should always be recovered on a vehicle transporter¹ and should only be towed for **short distances**, for example, if it is causing an obstruction or if it requires winching onto a transporter.

If moving the vehicle in such a situation:

1. Remove the towing eye from its storage location in the vehicle tool kit (located in the boot storage area). Insert the towing eye carefully through the grill and install to the exposed female threads (A) until fully engaged against the vehicle body.

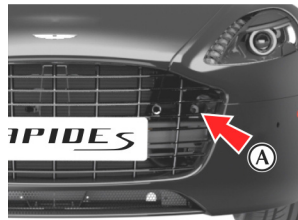

📖 *The towing eye has a left hand thread.*

📖 *Protect vehicle paint work when installing the towing eye.*

2. When being towed use the footbrake very gently when required, to prevent excessive slack in the tow rope.

Parklock

If the vehicle fails to start or has broken down, the automatic transmission will move into P (Park) to prevent unintended vehicle movement. The parklock will not release. Call Aston Martin Assistance.

Jump Start From Another Vehicle

⚠ **Warning: The donor vehicle must have a 12 volt battery and a negative (-) earth terminal to make sure that the correct battery polarity is maintained.**

⚠ **Apart from vehicle recovery, this vehicle must not be driven if the vehicle battery is incapable of starting the engine. In this case the vehicle battery must be replaced.**

⚠ **If the voltage or earth of the donor vehicle is different or not known, do not attempt starting in the way described.**

If this vehicle will not start due to a discharged battery, it may be started, **for vehicle recovery**, by connecting the battery from another vehicle (donor) to this vehicle (recipient).

¹ The recommended method for a recovering vehicle is to have it transported in a purpose built, covered, vehicle transporter.

Jump Start Procedure

⚠ **Remove rings, metal watch bands and any other jewellery.**

⚠ **Set all electrical motors and ancillaries in both vehicles to OFF.**

⚠ **Set all lamps to OFF except those needed to protect vehicles or illuminate the work area.**

📖 *Recharge time will depend on the initial 'state of health' of the discharged battery.*

📖 *If the vehicle still will not start, consult your Aston Martin Dealer.*

1. Position the donor vehicle so that the connecting cables will reach into the recipient engine bay. Apply the park brake and leave the engine running.
 2. Access the jump start terminal in the recipient engine bay.
 3. Connect the positive cable between the positive terminal of the donor battery and the jump start terminal of the recipient vehicle (A).
 4. Connect the negative cable between the negative terminal of the donor battery and a good earth (negative) point in the recipient engine bay (i.e. alternator mounting bracket).
 5. Start the donor vehicle engine and increase the engine speed and run at about 1500 – 2000 rpm for two minutes¹.
- 📖 *The donor vehicle must be set to OFF. If the donor vehicle is not set to OFF the recipient vehicle will not start.*
6. Set the donor vehicle off.
 7. Start the engine of the recipient vehicle.

¹ Charge time can depend on the battery state of the donor vehicle.

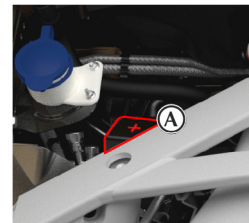
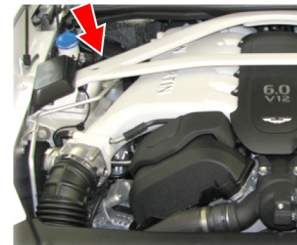

8. Leave the jump start cables attached and the engines running for 2 to 3 minutes to allow the battery to charge.
9. Remove the jump start cables, first the negative cable from both vehicles and then the positive cable from both vehicles. Allow the recipient engine to run until the discharged battery is sufficiently recharged (15 to 20 minutes) to start the engine without assistance. Set the engine to OFF and restart the engine. Take the vehicle on a long run to fully charge the battery. Contact your Aston Martin Dealer to have the battery checked or replaced.

Vehicle Battery

⚠ Warning: Battery posts, terminals and related accessories contain lead and lead compounds. Wash hands after handling.

⚠ Warning: Do not allow flames, sparks or lighted substances to come near the battery. Batteries normally produce explosive gases which can cause personal injury. When working near the battery, always shield your face and protect your eyes. Always have sufficient ventilation.

⚠ Warning: When lifting a plastic cased battery, excessive pressure on the end walls could cause acid to flow through the vent caps, resulting in personal injury, damage to the vehicle or battery. Lift the battery with a battery carrier or with your hands on opposite corners.

⚠ Warning: Keep batteries out of reach of children.

⚠ Warning: Batteries contain sulphuric acid. Avoid contact with skin, eyes or clothing. Shield your eyes when working near the battery to protect against possible splashing of acid solution. In case of acid contact with skin or eyes, flush immediately with water for a minimum of 15 minutes and get prompt medical attention. If acid is swallowed, get medical help immediately.

⚠ The engine must never be run with the vehicle battery disconnected.

⚠ Apart from vehicle recovery, this vehicle must not be driven if the vehicle battery is incapable of starting the engine. In this case the vehicle battery must be replaced. Contact your Aston Martin Dealer.

The vehicle battery is located under the rear right seat. It is maintenance free and should only require checking by your Aston Martin Dealer during regular vehicle services.

Vehicle Battery Disposal

It is the responsibility of the vehicle owner when disposing of automotive batteries to do it in an environmentally correct manner. The incorrect disposal of a vehicle (lead-acid) battery can be extremely hazardous to health and the environment. Most batteries contain materials that, when disposed of incorrectly, may leak into the environment. This can contribute to soil and water pollution and endanger wildlife.

Do not dispose of a battery in fire or water.

Follow your local authorised standards for disposal. Call your local authorised recycling centre to find out more about recycling automotive batteries.

Do not dispose of your vehicle battery in the household waste.



Vehicle Battery Charge

Warnings

The following warnings are located on the vehicle battery.



Various systems, such as the clock, security systems and Infotainment centre system continue to drain battery power even with the ignition OFF.

A **new fully charged** battery has the ability to start this vehicle, if left unused, for up to 45 days without a battery conditioner being used.

In cold climates this time may be reduced.

Aston Martin recommend that if this vehicle is to be left unused for 10 days or more a battery conditioner should be used if mains power is available.

Battery charge can be drained excessively in a number of ways:

- If the vehicle is unused for long periods of time.
- If the vehicle is used regularly but only for short journeys, e.g. less than 48 km (30 mile) a journey.
- If electrical systems are in use without the vehicle engine running.
- If the vehicle key is left in the ignition control for long periods of time without the engine operating.

Excessive battery drain would ultimately mean that the battery would not be able to start the engine.

Battery Conditioner

(Option)

Warning: Do not attempt to start the vehicle with a battery conditioner connected to the mains supply.

Warning: Do not smoke near the vehicle battery. Prevent flames and sparks. Explosive gasses are given off by batteries during charging.

A battery conditioner is designed for conditioning of partially or fully charged batteries. It will not effectively charge a discharged battery.

For indoor use only. Disconnect mains supply before connecting or disconnecting the battery charger to the vehicle.

The Aston Martin battery conditioner is suitable for use on all types of 12 volt lead acid batteries.

With the boot lid left open the vehicle doors can be locked and armed.

If this vehicle is not going to be used for a period of time, and **mains power is available**, use a battery conditioner to maintain the battery charge level.



When connected the battery conditioner will maintain a small trickle charge to keep the battery in a fully charged state. The battery conditioner may be left in this state indefinitely.

To Connect a Battery Conditioner

1. Insert the accessory socket plug (B) into the accessory socket (A) located in the boot right side.
2. Insert the mains plug (C) into the mains supply.
3. Gently close, but do not latch, the boot lid. This avoids possible damage to the boot lid water seal from the battery conditioner power cable.

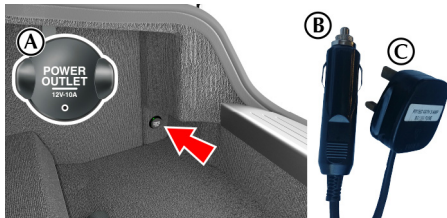

To remove the battery conditioner first disconnect from the mains supply, then remove from the vehicle accessory socket.

Battery Protection Mode

! Replace the battery as soon as possible, if the battery is not capable of starting the engine.

Using the vehicle electrical systems, i.e. the infotainment system, with the vehicle key at position '1' (ignition OFF) will drain the battery charge. Eventually the battery will drain to such a low level that it will not start the engine.

To avoid this happening, a series of safety mechanisms shut down non-essential electrical systems before excessive battery drain takes place.

Frequently Asked Questions

What is the first sign of battery protection mode?

Warning messages are shown in the message centre.

What should I do next?

Set all unnecessary electrical systems to OFF to reduce battery drain. Start the engine to recharge the battery. Run the engine for a reasonable length of time.

What happens if I ignore the warning messages?

After approximately 2 to 10 minutes (dependent on the rate of battery charge drain) the following message is shown in the infotainment display:



If the audio system is ON, the audio will then stop playing.

What should I do if these messages are shown?

Set all unnecessary electrical systems to OFF. Start the engine to recharge the battery. Run the engine for a reasonable length of time.

What happens if I ignore second warning messages?

The infotainment system will shut down in two minutes. No other electrical system will be shut down. This significantly reduces the rate of battery drain. The following functionality will be lost:

- Rear seat Entertainment (optional)
- Navigation System
- Audio System

What should I do if the infotainment system shuts down?

Start the engine to recharge the battery. Run the engine for a reasonable length of time.

The infotainment system will not operate without the engine running until the battery has regained its charge. With the engine running the infotainment system will start up.

What is a reasonable length of time to run the engine?

The vehicle battery normally requires a journey of approximately 48 km (30 miles) to recharge. Additionally, you can use the battery conditioner to restore the vehicle battery charge when the vehicle is parked.

What if I cannot restart the engine?

If the battery has been run down to a point where it will not start the engine then an external battery charger¹ will be required or your vehicle will require a 'jump start' (Refer to 'Jump Start From Another Vehicle', page 12.16).

¹. A battery conditioner is designed for conditioning of partially or fully charged batteries. It will not effectively charge a discharged battery.

Fuse Boxes

Electrical systems are protected by fuses. If any lamps, accessories, or controls do not function, inspect the applicable fuse.

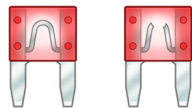

If a fuse has blown, the inside element will be melted. If the same fuse blows again, avoid using that system and consult your Aston Martin Dealer as soon as possible.

Fuse Box Location

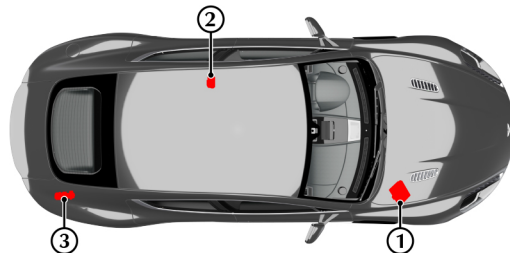

[1] : Engine bay fuse box (passenger side)

[2] : Rear passenger seat fuse box (under left side seat)

[3] : Boot fuse box

Engine Bay Fuse Box

Fuse	Rating	Function
F1	10A	Engine Management System Electronic Control Unit B - Permanent Power Feed
F2	10A	Engine Fuse Box Relays
F3	10A	Right Side Valved Airbox / Crank Relay / Electric Vapour Management Valve
F4	20A	Engine Management System (Bank A)
F5	20A	Engine Management System (Bank B) / Left Side Valved Airbox
F6	15A	Universal Exhaust Gas Oxygen and Catalyst Monitor Sensor (Bank B)
F7	15A	Ignition Coils (Bank B)
F8	10A	Variable Valve Timing (Bank B)
F9	20A	Fuel Injectors (Bank B)
F10	10A	Air Conditioning Compressor Clutch
F11	15A	Dual Horn

Fuse	Rating	Function
F12	10A	Engine Management System Electronic Control Unit A Permanent Power Feed
F13	20A	Fuel Injectors (Bank A)
F14	10A	Variable Valve Timing (Bank A)
F15	25A	Starter Motor
F16	15A	Ignition Coils (Bank A)
F17	5A	Not Available
F18	15A	Universal Exhaust Gas Oxygen and Catalyst Monitor Sensor (Bank A)
F19	30A	Not Available
F20	30A	Not Available
F21	30A	Not Available
F22	5A	Mass Air Flow Sensor (Bank A), Oil Level/Temperature Sensor
F23	-	Not Available

Fuse	Rating	Function
F24	5A	Not Available
F25	5A	Mass Air Flow Sensor B, Engine Coolant Level Sensor
F26	20A	Headlamp Wash Pump
F27	40A	Anti-lock Braking System Module
F28	10A	Vehicle Key Reader / Steering Angle Sensor, Fuel Tank Leakage Diagnostic Pump / Anti-lock Braking System Module / Electronic Steering Column Lock / Brake Pedal Switch
F29	20A	Anti-lock Braking System Module
F30	5A	Anti-lock Braking System Module
F31	40A	Engine Fuse Box Relays
F32	30A	Wiper Motor (Slow)
F33	30A	Wiper Motor (Fast)
F34	15A	Not Available
F35	80A	Fan Control Module (x2)

Rear Passenger Seat Fuse Box

Fuse	Rating	Function
F1	5A	Not Available
F2	30A	Right Side Electric Park Brake Motor
F3	15A	Exhaust Bypass Valve
F4	10A	Driver Centre Stack Switch Pack
F5	30A	Left Side Electric Park Brake Motor
F6	10A	Rear Centre Stack Switch Pack / Rear LCD / Camera
F7	5A	Electric Park Brake Module
F8	-	Not Available
F9	30A	Fuel Pump Control Module
F10	25A	Left Side Rear Door Electronic Control Unit
F11	10A	Transmission Control Module
F12	20A	Adaptive Damping System
F13	10A	Rear Ambient LEDs/ Left Side Rear Interior LED/Left Side Rear Footwell LED / Left Side Rear Seat Release Switch/Rear Header LED

Boot Fuse Box

Fuse	Rating	Function
F14	10A	Driver Centre Stack Switch Pack
F15	10A	Rear Centre Stack Switch Pack / Rear LCD
F16	25A	Left Side Boot Power Socket
F17	15A	Rear Heating / Ventilation and Air Conditioning Blower
F18	30A	Not Available
F19	5A	Satellite Navigation
F20	5A	Adaptive Damping System
F21	25A	Left Side Front Door Electronic Control Unit
F22	5A	Park Distance Control

Fuse	Rating	Function
F1	-	Not Available
F2	20A	Right Side Boot Power Socket
F3	30A	Heated Rear Window
F4	10A	Rear Seat Entertainment Headphones
F5	30A	Rear Seat Entertainment Module
F6	5A	B&O Amplifier
F7		Not Available
F8	10A	Left Side Rear Seat Release
F9	10A	Right Side Rear Seat Release
F10	25A	Right Side Rear Door Electronic Control Unit
F11	-	Not Available
F12	-	Not Available
F13	15A	Powered Latch Module

Fuse	Rating	Function
F14	5A	Right Seat Rear Seat Release Switch
F15	5A	Right Side Rear Interior LED / Right Side Rear Footwell LED
F16	5A	CD Changer
F17		Not Available
F18	5A	Rear Seat Entertainment DVD Changer
F19	5A	Digital Tuner
F20	15A	Right Side Rear Seat Electronic Control Unit
F21	25A	Right Side Front Door Electronic Control Unit
F22	15A	Left Side Rear Seat Electronic Control Unit

Headlamp

⚠ Warning: High Intensity Discharge (HID) bulbs produce a very high voltage. They should only be serviced by an Aston Martin Dealership.

High Intensity Discharge (HID) bulbs are used for the combined main and dipped beam. HID systems produce a brilliant white light by establishing a high voltage electrical arc between two electrodes within a sealed glass tube. Once the arc is established, the voltage lowers to normal operating conditions.

HID bulbs are not renewable.

Contact your Aston Martin Dealer if a HID bulb fails to operate.

 *Headlamp Units: Condensation: The headlamp units will generate condensation under certain conditions. However, this should clear after approximately 10 minutes after the headlamps have been set to ON.*

Other External Lamps

High Level Stop Lamp

The high level mounted stop lamp unit consists of LEDs and is not repairable. If a high level mounted stop lamp LED fails, contact your Aston Martin Dealer.

Front Indicator and Parking Lamps

If a front indicator or parking bulb fails to operate, contact your Aston Martin Dealer. These lamps consist of LEDs and are not repairable.

Side Indicators

The side indicators comprise of five LEDs in each front wing side strake and are not repairable. If a side indicator LED fails, contact your Aston Martin Dealer.

Registration Plate Lamps

Specialist tools are required to access the registration bulb. If a registration lamp bulb fails, contact your Aston Martin Dealer.

Rear Lamp Clusters

The rear indicators, stop and tail, reversing lamps and rear fog LEDs are contained in a sealed lamp cluster unit, one either side of the vehicle. The lamp cluster is not repairable. If a rear lamp fails, contact your Aston Martin Dealer.

Boot Lamps

The boot illumination comprises four LEDs, two each side of the boot area and are not repairable.

If a boot LED fails contact your Aston Martin Dealer.

 *LEDs can last tens of thousands of hours and are resistant to heat, cold, shock and vibration.*

Internal Lamps

The puddle lamps on each door and the front and rear footwell lamps are bulbs which can be renewed. All other internal lamps are LEDs which are not repairable. If an LED lamp fails to operate, contact your Aston Martin Dealer.

 LEDs can last tens of thousands of hours and are resistant to heat, cold, shock and vibration.

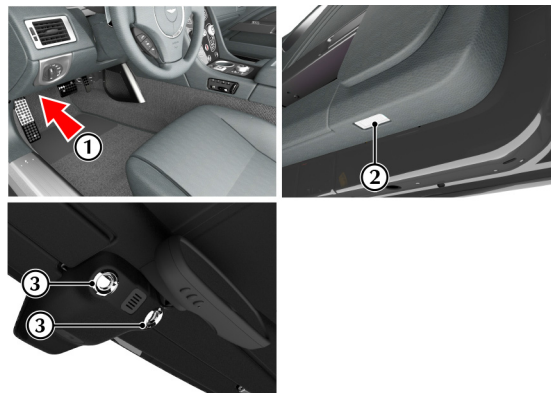

[1] : Front footwell lamps

[2] : Door puddle lamps

[3] : Front reading lamps

[4] : Rear footwell lamps

[5] : Rear reading lamps

To renew a bulb:

1. Take care not to damage the vehicle trim.
2. Lever out the lens unit and replace the faulty bulb. **Door puddle lamps only:** Open the access flap and replace the faulty bulb.
3. Press the lens unit into its housing until it clips into position.

Tourist Headlamp Adjustment

The headlamp beams can be adjusted to give a flat beam. This prevents dazzling oncoming vehicles if driving in another country where the road priority changes, i.e. from driving on the right to driving on the left.

Remove the panel in each wheel arch liner. Turn the steering to the opposite lock from the headlamp unit. Using a flat blade, i.e. a screwdriver or a small coin, release the screw on the access panel and remove the panel.

Remove the rubber cap and locate the headlamp adjust lever (A). Move the lever down to give a flat headlamp beam. Install the rubber cap and the wheel arch liner panel. Repeat for the other headlamp.

Remember to set the adjustment level back to normal beam (lever up) when back in your home country.

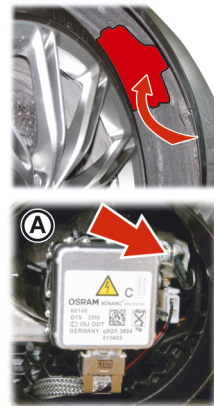

Door Window Reset

If power to the electric windows has been interrupted for any reason, they will fail to operate correctly until reset.

1. Sit in the driver's seat with all doors closed, insert the vehicle key into the ignition control and move to position 'II' (ignition ON).
2. Press firmly and hold the window switch until the window is at the maximum down position. Continue to hold the button for five seconds then release.
3. Pull back and hold the window switch until the window is in the maximum up position. Continue to hold the switch for a further five seconds, then release.
4. The window is now reset. Repeat for the other door windows.

Front Seat Reset

Should a front seat fail to move or the seat memory position fails to work this may show a loss of seat position in the vehicle's memory. If so, complete the seat reset procedure detailed below:

⚠ Warning: Do not sit in the seat while you do the seat reset procedure. Seat movement will restrict the occupancy area.

⚠ Warning: Make sure that there is nothing in front of, behind, or under the seat during the seat reset procedure.

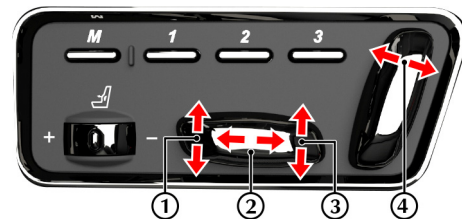

📖 The seat must be moved to its limit of travel and allowed to stall for 1 second for each axis. If the seat is not held at its limit of travel, the seat memory will not learn this as its fully travelled position.

1. Press the seat forward button (2) until the seat is fully forward.
2. Press the seat back button (4) until the seat back is fully backwards.
3. Press the seat down button (1) until the front of the seat is fully down.
4. Press the seat down button (3) until the rear of the seat is fully down.

The seat movement and position memory should now work correctly, if not contact your Aston Martin Dealer.

Door Drain Holes

Check the drain holes in the bottom face of each door periodically and clear if necessary with, for example, a short length of wire or a pipe cleaner.

Paint Work

Modern water based paints are much safer and more environmentally friendly than solvent based paints. Water based paints are however more susceptible to contamination and marking by corrosive substances. The following list is not exhaustive but does show the most common contaminants which may adversely affect your paint work:

- Bird droppings,
- Antifreeze,
- Tree sap,
- Oils and greases,
- Insect remains.

Wash such substances from the vehicle using clean warm water with vehicle shampoo at the earliest opportunity, especially in sunny weather which can accelerate contamination.

 *Other groups of contaminants may be added to this list as experience of water based paints and finishes increases.*

Washing

⚠ Warning: Washing and polishing agents containing silicone should not be applied to glass. This will reduce the efficiency of the windscreen wipers, causing smears which will reduce visibility, particularly during darkness and in the rain.

⚠ Commercially operated automatic vehicle washes, jet washes and power operated mops are not recommended. The detergents used can contain certain chemicals which may, over time, be detrimental to some exterior parts of the vehicle. Prolonged usage of automatic vehicle washes and power operated mops will also cause fine scratches in the paint surface.

Aston Martin recommends the use of AUTOGLYM vehicle care products or preparations of similar reputable manufacture for adding to the washing water. Make sure that the manufacturer's instructions are followed.

During the winter months, it is advisable to wash the vehicle more frequently, paying particular attention to the underside to combat the detrimental effects of any salt and sand contamination picked up from treated roads.

To delay the onset of corrosion developing on the brake components Aston Martin recommend that after washing this vehicle, the vehicle should be driven a short distance to make sure that all water and cleaning products have dried off.

For best results:

- Do not wash the vehicle in strong sunlight. Let the vehicle cool before washing.
- Do not use household soaps or detergents.
- Do not direct water hoses at full force around the door and boot lid seals.
- Do not use a brush on the car body as this will leave little scratches.

Suggested washing method:

1. Fill two buckets with water. Add a mild neutral detergent, as directed by the detergent manufacturer to one of the buckets.
2. Use a hose to remove all dust and mud residue from the vehicle. Don't use a strong jet, as this can rub grit over the paint and scratch it.
3. Soak a large clean wash mitt or a soft clean sponge in the soapy water, and begin applying it to the vehicle. Wash the vehicle section by section, starting at the top. Circle around the car several times, washing lower areas with each round.
4. Rinse the dirt out of the wash mitt or soft sponge in the bucket with plain water frequently.
5. After one section is washed, rinse it with the hose before moving on, don't let the soap dry on the paint as this can stain it. Always keep the vehicle wet, this will prevent droplets from drying on the paint and leaving water-spots.
6. Dry the car with a chamois leather before it air-dries.

Front Grille

Wash and clean the vehicle's front grille in the same way as the paint work, but make sure that the front grille is dried off completely leaving no water droplets on the grille (wipe the front grille last using a chamois leather): Chrome polish or other abrasive cleaners must not be used.

Road Wheels

To avoid possible damage to the alloy road wheels, wheel nuts and wheel centre trims, from a build up of brake dust wash and clean the alloy road wheels frequently, using a mild soapy water solution only. Do not use chemical alloy road wheel cleaners, as they can often have a high acid or alkaline content and could cause discolouration. Always clean one wheel at a time and do not allow the cleaning solution to dry on the wheel. Fully flush off with clean water.

Headlamp Lenses

Only use a mild soapy water solution when washing the headlamp lenses. Do not use cleaning materials which contain solvents. Cleaning materials which contain solvents, i.e. tar remover, petrol, waxes or polishes, may damage the headlamp lens.

Polishing

Approximately twice a year, a good quality polish should be applied to the body work and then buffed, using a soft lint free cloth.

The alloy wheel rims should be treated with a cleaner which is specifically manufactured for this purpose.

Upholstery, Trim, Carpets and Seats

⚠ Warning: Fumes from cleaning solvents may be dangerous in confined spaces. Make sure that the vehicle is well ventilated and follow the manufacturer's printed instructions when using these products.

⚠ Certain types of clothing, such as denim and vegetable tanned leather, are prone to 'dye transfer'. This can cause discolouration in the leather. Make sure that the affected areas are cleaned and re-protected as soon as possible.

The seats and soft trimmed components of this vehicle are covered in natural leather hide. In general, this natural leather upholstery requires little attention. The seats should be brushed with a soft brush from time to time and may be cleaned occasionally with a cloth dampened in soap and water.

Do not use detergents, quick cleansers or furniture polishes. These products may initially give an impressive result, but their use will lead to rapid deterioration of the leather and will invalidate the warranty. Several times a year, a leather conditioner or preservative should be used. Appropriate care materials are obtainable from your Aston Martin Dealer.

Alcantara roof linings and other soft trimmed areas may be brushed with a soft brush. Stains from water based substances such as coffee, tea or soft drinks should be cleaned as soon as possible with mild soap and water.

The brushed and anodised aluminium trim should be cleaned using a dry clean lint free cloth.

Consult your Aston Martin Dealer for instructions on the removal of more difficult stains such as oil, grease or ballpoint ink.

Carpets should be cleaned regularly with a vacuum cleaner. Any stains or grease marks should be removed with a good quality solvent suitable for use on carpets.

Care and Maintenance of Seat Belts

⚠ Do not allow seat belts to be retracted until they are completely dry.

To make sure that the restraint webbings are in correct working order, regularly check the seat belts. Look for fraying, cuts, burns and similar problems. Make sure that the latches and buckles operate correctly. If a seat belt is not in good condition or is not working correctly, consult your Aston Martin Dealer.

Any seat belt that has been worn during a serious collision should be replaced by an Aston Martin Dealer.

To clean the seat belts, use mild soap and water; do not use bleach, solvents or dyes, as they can weaken the material. Allow the seat belts to dry thoroughly before use.

Under Bonnet Cleaning

Under bonnet cleaning using high pressure hoses or steam cleaners should not be carried out. The electronic control module connections and fuse boxes can be damaged by indiscriminate use of high pressure cleaning equipment.

Vehicle Storage

Recommendations

 *These recommendations apply to new and pre-owned vehicles either in dealer or customer ownership.*

If your vehicle is not to be used for periods in excess of three months it should be stored in a dry, well ventilated building.

1. Drive the vehicle for a sufficient distance to warm the oil in the engine and the transaxle; make sure that the internal components of the engine are lubricated.
2. Check the engine coolant level. Top up if necessary with the correct antifreeze and water solution.
3. In order to take the weight off the tyres, raise the vehicle with a jack and place supports under the front and rear suspension. If the vehicle is not raised from the ground, increase the tyre pressures to 3.4 bar. Cover the tyres to exclude any light. Turn the wheels $\frac{1}{4}$ turn every month to avoid tyre flat spots.
4. If mains power is available, use a battery conditioner to maintain the battery in a fully charged state.

5. Once a month:
 - 5.1 Disconnect the battery conditioner (if installed).
 - 5.2 Start and operate the engine until it is fully warmed up.
 - 5.3 Check there are no fluid leaks.
 - 5.4 Set the ignition to OFF.
 - 5.5 Connect a battery conditioner.
 - 5.6 Check and correct tyre pressures if necessary. When returning the vehicle to normal service, set the tyre pressures to normal specification before driving on the road.

 *Excessive sunlight and humidity can increase the vehicle temperature, which can cause damage to the vehicle interior and trim. If storing the vehicle in these conditions, Aston Martin recommend using a solar reflecting car cover to prevent any potential damage due to high temperatures.*

Extended Storage

For storage periods exceeding six months the following measures are recommended:

 *Do not drain the fuel system.*

1. Operate the engine until there is as small a quantity of fuel in the tank as is practical for storage purposes.
2. Inspect rubber connections of coolant system and have them renewed if necessary.
3. Wash the vehicle bodywork thoroughly and repair any paint blisters or patches of corrosion in order to prevent any further deterioration. Apply a suitable polish.
4. Clean the carpets and upholstery thoroughly. Treat all leather upholstery with an application of a leather conditioner or preservative.
5. If the storage building is dry then leave vehicle windows slightly open. If there is any tendency towards dampness close vehicle doors and windows and place an anti-moisture compound such as silica desiccant bags in an open metal container inside vehicle.
6. Cover vehicle with a cotton or fabric cover.

Recommissioning after Storage

Provided that the vehicle has been stored in accordance with the recommended procedure, only the following points should need attention before using your vehicle on the road.

1. Check the tyre pressures, inflate if necessary, lower the vehicle to ground.
2. Check the coolant level and, if necessary, top up with the correct antifreeze to water solution.
3. Check all fluid levels and top up as necessary.
4. Fill the fuel tank.

⚠ Starting the engine without sufficient lubrication can cause serious engine damage. Make sure that the engine oil pressure is established before starting the engine.

5. Start the engine normally and allow the engine to idle. Check that the oil pressure and ignition warning symbols go OFF (correct oil pressure and battery charging).
6. Raise the bonnet and check for leaks of fuel, oil and coolant.
7. Carefully test drive your vehicle and check the operation of all functions.

Braking performance can be impaired, initially, due to a fine film of corrosion on the brake disc surface. Drive conservatively and, when safe to do so, frequently apply the brakes until disc surfaces have been cleaned. Full braking performance should then be restored.

If in any doubt about the condition of your vehicle, have it checked by your Aston Martin Dealer.



ASTON MARTIN



Specifications

Engine	13.2
Transmission	13.2
Power and Torque	13.3
Performance	13.3
Fluids and Capacities.....	13.3
Steering.....	13.4
Suspension.....	13.5
Brakes	13.5
Wheels.....	13.5
Tyres	13.6
Bulbs.....	13.7
Vehicle Specification	13.7

Engine

All alloy, independent quad variable camshaft timing, overhead cam 48 valve V12.

Capacity: 5935 cc

Firing Order: 1 - 7 - 5 - 11 - 3 - 9 - 6 - 12 - 2 - 8 - 4 - 10

Idle Speed: 650 rpm

Bore: 89.0 mm (3.504 in)

Stroke: 79.5 mm (3.13 in)

Spark Plugs: NGK: SITR7A11G

Spark Plug Gap: 1.1 mm (0.043 in) +0.0/-0.1 mm (0.004 in)

Compression Ratio: 11.0:1

Ignition: 'Coil on Plug' ignition system.

Emission Control: Eight oxygen sensors (four per exhaust manifold). Six three-way catalytic converters (two per exhaust manifold and one main per bank). Evaporative loss purge.

Lubrication: Wet sump pressurised lubrication.

Fuel Delivery System: Multi point sequential fuel injection.

Electrics

Alternator: Denso SC5 200 Amps

Voltage Regulation: 14.4V \pm 0.5V @ 20°C

Battery: Banner 88 AH

Transmission

Automatic Transmission

Touchtronic III 8-speed with 'Shift By Wire' (SBW) gear shift technology.

Gear Ratios

1st	4.714
2nd	3.143
3rd	2.106
4th	1.667
5th	1.285
6th	1.000
7th	0.839
8th	0.667
Reverse	3.317

Final Drive

Ratio: 2.73:1. Multi-plate limited slip differential.

Power and Torque

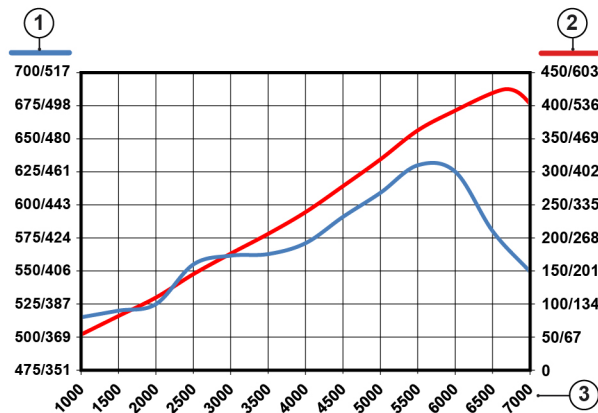

[1] : Torque (Nm / lbft)

[2] : Power (kW / Bhp)

[3] : Engine speed (rpm)

Performance

Maximum Power:

552 bhp (412 kW) @ 6650 rpm

565 bhp (421.3 kW) @ 6650 rpm (with optional performance pack)

Maximum Torque: 465 lb.ft (630 Nm) @ 5500 rpm

Maximum Speed (Where permitted): 203 mph (327 km/h)

Maximum Engine Speed: 7000 rpm

Fluids and Capacities

Recommended Fluids

Fuel: Recommended 98 RON Super Unleaded for optimum performance. 95 RON minimum.

Use of fuels containing more than 10% Ethanol are not recommended.

Engine Oil: Fully synthetic 0W-40 oil meeting the specifications detailed below can be used. No other viscosity grades or specifications are acceptable.

! To achieve the required high performance of synthetic lubricants, do not mix with mineral oils.

Authority

API
ACEA
ILSAC

Standard

SL / SJ / EC / CF
A3 / B3 / B4
GF3

Engine Coolant: 50% water, 50% Havoline XLT

Brake Fluid: React Performance DOT 4

Power Steering Fluid: Pentosin CHF-11S

Air Conditioner Refrigerant: (Market Dependent)

HFO 1234YF

HFC 134A

 Vehicle air conditioning refrigerant is shown on air conditioning label on the right side of the engine bay.

 **Refrigerant gas types must not be mixed. If you do, the air conditioning system can be damaged. If in doubt, consult your Aston Martin Dealer.**

Capacities

Engine Sump (including filter): 13.1 litres

Engine Cooling System: 15 litres

Power Steering System: 1.3 litres

Screen Washer Reservoir: 5.5 litres

Fuel Tank: 90.5 litres (Approximately 88.5 litres usable.)

Steering

Rack and pinion, servotronic speed sensitive power assisted steering.
Column tilt and reach adjustments.

Turns Lock to Lock: 2.75

Turning Circle: 12.5 m (Kerb to Kerb)

Total Toe: Refer to your Aston Martin Dealer for the correct data.

Suspension

Front: Aluminium independent double wishbone incorporating anti-dive geometry. Coil over aluminium monotube dampers and anti-roll bar.

Rear: Aluminium independent double wishbone incorporating longitudinal control arms. Coil over aluminium monotube dampers and anti-roll bar.

Features

- Dynamic Stability Control (DSC)
- Adaptive Damping System (ADS)
- Multi-stage Adaptive Damping System (ADS) (Optional)

Brakes

Footbrake

Combination Cast Ventilated Discs

Combination cast front discs with aluminium centre bell and steel ventilated and grooved discs. Rear discs are ventilated and grooved steel discs.

	Front	Rear
Diameter	400 mm	360 mm
Calipers	Six piston	Four piston

Park Brake

Electrically operated independent park brake calipers on each rear brake disc.

Brake System Features

- Anti-lock Braking System (ABS)
- Hydraulic Brake Assist (HBA)
- Electronic Brake force Distribution (EBD)
- Traction Control (TCS)

Wheels

Aston Martin Aluminium Alloy

Front	Rear
8.5J x 20	11J x 20

Aston Martin Lightweight Forged Aluminium Alloy¹

Front	Rear
8.5J x 20	11J x 20

¹. Option.

Wheel Nut Torque

Tighten all wheel nuts in two stages.

1. Tighten every second nut (as shown in the diagram) to 80 Nm (60 lb/ft) until all five nuts are tightened.
2. Tighten every second nut (as shown in the diagram) to 180 Nm (133 lb/ft) until all five nuts are tightened.



Tyres

The original equipment tyres, including winter tyres, installed to this vehicle are an approved specification, designated by 'AMR' on the sidewall.

Summer Tyres

	Front	Rear
Bridgestone S001 'AMR'	245/40 ZR 20 (95Y)	295/35 ZR 20 (105Y)

Winter Tyres

⚠ Warning: When winter tyres are fitted, the maximum speed limit of the vehicle could be reduced. Winter tyre speed limits and information should be provided upon installation of the winter tyres. Please consult your Aston Martin Dealer for more information.

	Front	Rear
Bridgestone Blizzak 'AMR'	245/40 ZR 20 (95W)	295/35 ZR 20 (105W)

Tyre Loading

Tyres installed to this vehicle shall have a maximum load rating not less than 690 kg (1521 lbs) front and 925 kg (2039 lbs) rear, or a load index of 95 (front) and 105 (rear) and a speed category of ZR.

Tyre Air Pressures

Cold Inflation (All Tyres)

Front	Rear
2.5 bar	2.6 bar

Bulbs

	Rating	Type
Headlamp dipped and main beam	35W	D1S HID
Front indicator lamps		LED
Parking lamp		LED
Door lamps	5W	W5W
Side repeater		LED
Front and rear footwell lamps	5W	W5W
Rear quarter lamps / boot lamps / reading lamps		LED
High mounted stop lamp		LED
Registration plate lamps	5W	W5W

The rear lamp cluster is a sealed unit. If any rear cluster lamp fails to operate contact your Aston Martin Dealer.

Vehicle Specification

Body

Four door coupe with four seats.
Extruded aluminium bonded body structure with aluminium and composite body panels and extruded aluminium door side-impact beams.

Towing

This vehicle is not engineered to tow any form of caravan, boat or trailer.

No towing devices are approved to install to this vehicle, other than a front towing eye to aid recovery or loading of this vehicle onto a transporter.

Vehicle Weights

Kerb Weight	1990 kg
Gross Vehicle Weight (GVW)	2410 kg
Boot Load₁	40 kg

₁. (Maximum load, evenly distributed.)

Interior Dimensions

	Front	Rear
Effective Headroom	932 mm	936 mm
Shoulder Room	1392 mm	1322 mm
Hip Room	1410 mm	1100 mm
Effective Legroom	1086 mm	765 mm

Boot Configuration

	Volume
Divider up	223 ltr
Divider down	393 ltr
Divider down, rear seats down	1029 ltr

Exterior Dimensions

 Ride height is measured at Gross Vehicle Weight (GVW). Dimensions shown in millimetres.

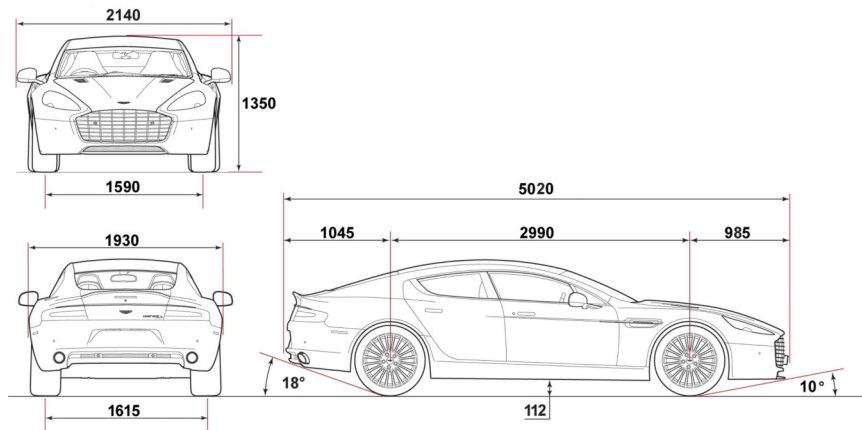



Service

Pre-delivery Inspection	A.2
Servicing	A.4
Service Record	A.7
Replacement of Airbag Units	A.28
Replacement of Seat Belt Pre-tensioners	A.28
Field Service Actions	A.28
Service Action Recalls	A.29

Pre-delivery Inspection

This free series of checks is carried out on the vehicle by the Selling Dealer before delivery. The checks make sure that you receive a vehicle which matches the high quality standards set by Aston Martin Limited.

The list below applies to all Aston Martin vehicles. Your Aston Martin may or may not have all or some of the functionality listed.

Make sure that the entry is stamped and signed as completed. The following checks will be made:

Levels and Leaks

- Engine oil
- Power steering oil
- Brake fluid
- Clutch fluid
- Engine coolant level
- Engine coolant specific gravity
- Windscreen washer fluid
- Fuel system
- Transaxle leak check
- Lift glass
- Battery.

Mechanical Functions

- Gear selection
- Clutch operation
- Throttle pedal operation
- Park brake operation
- Steering column adjustment and lock operation
- Seat adjuster rails
- Bonnet release and catch
- Door operation and locks
- Storage compartments
- Rear view mirror
- Boot release and catch
- Lift glass release and catch
- Seat belt operation.

Electrical Checks

- Battery condition
- Gear selection
- Heated rear window
- Windscreen and headlamp washers
- Windscreen wipers
- Climate control

- Infotainment centre operation
- All speakers
- Reversing, registration plate and brake lamps
- Side and headlamps
- Rear fog lamps
- Hazard warning lamps
- Instrument illumination and dimmer
- Gauges and warning symbols
- Centre stack controls
- Horns
- Reset clock
- Blower motor
- Seat belt warning system
- Security system and vehicle key
- Interior lamps
- Cigar lighter (Option)
- All seat functions
- Door window mechanisms
- Door and boot lamps
- Central locking system
- Filler flap lock operation
- Door mirror adjustments

- Interrogate fault codes
- Record battery open-circuit voltage
- Tyre pressure sensing
- Centre console controls.

Wheels and Tyres

- Install locking road wheel nuts (option)
- Check road wheel nuts torque
- Tyre pressures
- Tyre orientation.

Road Test

- Engine
- Clutch
- Transaxle
- Steering
- Brakes
- Wheel balance
- Adaptive dampers
- Dampers
- Exhaust by-pass system
- Gear shift operation
- Noise, vibration or harshness

- Climate control performance
- Instruments operation
- Seat belt and buckle operation
- Steering wheel alignment
- Dynamic stability control, traction control, adaptive damping and anti-lock braking system operation
- Transmission oil cooler.

Final Checks

- Drive belt tensioner operation
- Fuel and brake pipe security
- Fuel and fluid leaks
- Security of cooling hoses
- Exhaust catalyst security.

Hand-over Preparation

- Check function of locks and vehicle keys
- Clean bodywork and road wheel arch liners.
- Clean off all transit labels
- Valet vehicle
- De-grease windscreen
- Install carpets
- Remove interior protection

- Check owner's guidebook
- Check tools
- Install registration plates
- Tyre sealant kit
- Towing eye
- Battery conditioner (option)
- Field service actions and recall status.

Free Pre-delivery Inspection

Service Actions Checked:	Yes / No
Open Service Actions Completed:	Yes / No
Signature:	
Date:	

Servicing

Service Periods

Vehicle servicing is every 10,000 miles or 12 months, which ever occurs first.

- 10,000 mile or 12 months
- 20,000 mile or 24 months
- 30,000 mile or 36 months

Service Tables

The following service schedules are recommended for this vehicle. The schedules may be modified if necessary. Please consult your Aston Martin Dealer for details of any service schedule updates.

10,000 miles / 12 months	20,000 miles / 24 months	Item
Pre Maintenance Work		
		Install the vehicle protection kit.
		Check the Diagnostic Trouble Codes (DTCs).
Under Body		
x	x	Examine the condition, operation and attachment of the engine, transmission mounting system and check for leaks.
x	x	Examine the condition, operation and attachment of the exhaust system, heat shields, bypass valve operation and check for leaks.
x	x	Examine the condition, operation and attachment of the suspension and steering system for wear. Examine for leaks.
x	x	Examine the condition, operation and attachment of the braking system for wear and adjustment. Examine for leaks.

10,000 miles / 12 months	20,000 miles / 24 months	Item
x	x	Examine the condition, operation and attachment of the park brake system for wear and adjustment.
x	x	Examine the condition, operation and attachment of the drive shafts.
x	x	Examine the condition, operation and attachment of the wheel arch liners and under body protection.
x	x	Examine the condition, operation and attachment of the cooling pack assembly. Examine for leaks..
x	x	Examine the condition, operation and attachment of all under body fluid pipes and hoses and check for leaks.
5 Years		Replace engine coolant.
	x	Manual transaxle: Check the oil level. Fill if necessary
40,000 mls/64,000 km		Manual transaxle: Replace the oil and clean the filter.
	x	Automatic Transmission: Check and adjust the oil level in the differential.
60,000 mls/96,000 km		Automatic Transmission: Replace the oil and clean the filter in the differential.
x	x	Replace the brake fluid.

10,000 miles / 12 months	20,000 miles / 24 months	Item
Upper Body		
x	x	Replace the engine oil.
x	x	Replace the engine oil filter.
30,000 mls/48,000 km		Replace the pollen filter and air filter (optional).
x	x	Examine the condition, operation and attachment of the accessory drive belt.
x	x	Examine the condition, operation and attachment of the power steering system. Examine for leaks.
x	x	Examine the condition, operation and attachment of the brake system. Examine for leaks.
x	x	Examine the condition, operation and attachment of the fuel system. Examine for leaks.
x	x	Examine the condition, operation and attachment of the air conditioning system. Examine for leaks.
x	x	Check all power steering system fluid levels and adjust accordingly. Check for leaks.

10,000 miles / 12 months	20,000 miles / 24 months	Item
x	x	Check all braking system fluid levels and adjust accordingly. Check for leaks.
x	x	Check all cooling system fluid levels and adjust accordingly. Check for leaks.
x	x	Check all screen and headlight wash system fluid levels and adjust accordingly. Check for leaks.
70,000 mls/112,000 km		Replace the spark plugs.

10,000 miles / 12 months	20,000 miles / 24 months	Item
General		
x	x	Examine the condition, operation and attachment of all the occupant restraint systems.
x	x	Examine the condition, operation and attachment of all the door locks, latches, hinges, bonnet catches. Lubricate if necessary.
x	x	Examine the condition, operation and attachment of the wiper blades and wash system including headlights.
x	x	Examine the condition, operation and attachment of all the light units and the horn.
x	x	Examine the condition of the road wheels. Check the wheel nut torque is correct.
x	x	Complete the tyre report. If necessary, adjust the tyre pressures.
x	x	Complete the functional test of the tyre pressure sensor system.
x	x	Reset the service interval indicator.

Service Record

The following service records cover the regular services at 10,000 miles or 12 months intervals, which ever occurs first. Make sure that at each service the appropriate entry is stamped and signed as completed.

Vehicle Model:

Registration Number:

Vehicle Identification Number (VIN):

Delivery Date:

10,000 miles / 12 months	20,000 miles / 24 months	Item
		Road Test
x	x	Check the powertrain system for excessive noise, vibration and harshness.
x	x	Check the braking system for excessive noise, vibration and harshness.
x	x	Check the suspension system for excessive noise, vibration and harshness.
x	x	Check the steering system for excessive noise, vibration and harshness.
x	x	Check the wheels and tyres for excessive noise, vibration and harshness.
x	x	Check the cabin environment for excessive noise, vibration and harshness.
x	x	Check the driver information and warning system operation.

10,000 Miles or 1st Year

Odometer:

Technician Name:

Date:

Next Service Due:

Authorised Dealer Stamp

Service Advisor Name:

Service Advisor Signature:

Service Details

Service Actions Checked: Yes / No

Air Filter Changed: Yes / No

Pollen Filter Changed: Yes / No

Spark Plugs Changed: Yes / No

Anti Corrosion Inspection: Yes / No

Fluids Changed:

Additional Service Information

20,000 Miles or 2nd Year

Odometer:

Technician Name:

Date:

Next Service Due:

Authorised Dealer Stamp

Service Advisor Name:

Service Advisor Signature:

Service Details

Service Actions Checked: Yes / No

Air Filter Changed: Yes / No

Pollen Filter Changed: Yes / No

Spark Plugs Changed: Yes / No

Anti Corrosion Inspection: Yes / No

Fluids Changed:

Additional Service Information

30,000 Miles or 3rd Year

Odometer:

Technician Name:

Date:

Next Service Due:

Authorised Dealer Stamp

Service Advisor Name:

Service Advisor Signature:

Service Details

Service Actions Checked: Yes / No

Air Filter Changed: Yes / No

Pollen Filter Changed: Yes / No

Spark Plugs Changed: Yes / No

Anti Corrosion Inspection: Yes / No

Fluids Changed:

Additional Service Information

40,000 Miles or 4th Year

Odometer:

Technician Name:

Date:

Next Service Due:

Authorised Dealer Stamp

Service Advisor Name:

Service Advisor Signature:

Service Details

Service Actions Checked: Yes / No

Air Filter Changed: Yes / No

Pollen Filter Changed: Yes / No

Spark Plugs Changed: Yes / No

Anti Corrosion Inspection: Yes / No

Fluids Changed:

Additional Service Information

50,000 Miles or 5th Year

Odometer:

Technician Name:

Date:

Next Service Due:

Authorised Dealer Stamp

Service Advisor Name:

Service Advisor Signature:

Service Details

Service Actions Checked: Yes / No

Air Filter Changed: Yes / No

Pollen Filter Changed: Yes / No

Spark Plugs Changed: Yes / No

Anti Corrosion Inspection: Yes / No

Fluids Changed:

Additional Service Information

60,000 Miles or 6th Year

Odometer:

Technician Name:

Date:

Next Service Due:

Authorised Dealer Stamp

Service Advisor Name:

Service Advisor Signature:

Service Details

Service Actions Checked: Yes / No

Air Filter Changed: Yes / No

Pollen Filter Changed: Yes / No

Spark Plugs Changed: Yes / No

Anti Corrosion Inspection: Yes / No

Fluids Changed:

Additional Service Information

70,000 Miles or 7th Year

Odometer:

Technician Name:

Date:

Next Service Due:

Authorised Dealer Stamp

Service Advisor Name:

Service Advisor Signature:

Service Details

Service Actions Checked: Yes / No

Air Filter Changed: Yes / No

Pollen Filter Changed: Yes / No

Spark Plugs Changed: Yes / No

Anti Corrosion Inspection: Yes / No

Fluids Changed:

Additional Service Information

80,000 Miles or 8th Year

Odometer:

Technician Name:

Date:

Next Service Due:

Authorised Dealer Stamp

Service Advisor Name:

Service Advisor Signature:

Service Details

Service Actions Checked: Yes / No

Air Filter Changed: Yes / No

Pollen Filter Changed: Yes / No

Spark Plugs Changed: Yes / No

Anti Corrosion Inspection: Yes / No

Fluids Changed:

Additional Service Information

90,000 Miles or 9th Year

Odometer:

Technician Name:

Date:

Next Service Due:

Authorised Dealer Stamp

Service Advisor Name:

Service Advisor Signature:

Service Details

Service Actions Checked: Yes / No

Air Filter Changed: Yes / No

Pollen Filter Changed: Yes / No

Spark Plugs Changed: Yes / No

Anti Corrosion Inspection: Yes / No

Fluids Changed:

Additional Service Information

100,000 Miles or 10th Year

Odometer:

Technician Name:

Date:

Next Service Due:

Authorised Dealer Stamp

Service Advisor Name:

Service Advisor Signature:

Service Details

Service Actions Checked: Yes / No

Air Filter Changed: Yes / No

Pollen Filter Changed: Yes / No

Spark Plugs Changed: Yes / No

Anti Corrosion Inspection: Yes / No

Fluids Changed:

Additional Service Information

110,000 Miles or 11th Year

Odometer:

Technician Name:

Date:

Next Service Due:

Authorised Dealer Stamp

Service Advisor Name:

Service Advisor Signature:

Service Details

Service Actions Checked: Yes / No

Air Filter Changed: Yes / No

Pollen Filter Changed: Yes / No

Spark Plugs Changed: Yes / No

Anti Corrosion Inspection: Yes / No

Fluids Changed:

Additional Service Information

120,000 Miles or 12th Year

Odometer:

Technician Name:

Date:

Next Service Due:

Authorised Dealer Stamp

Service Advisor Name:

Service Advisor Signature:

Service Details

Service Actions Checked: Yes / No

Air Filter Changed: Yes / No

Pollen Filter Changed: Yes / No

Spark Plugs Changed: Yes / No

Anti Corrosion Inspection: Yes / No

Fluids Changed:

Additional Service Information

130,000 Miles or 13th Year

Odometer:

Technician Name:

Date:

Next Service Due:

Authorised Dealer Stamp

Service Advisor Name:

Service Advisor Signature:

Service Details

Service Actions Checked: Yes / No

Air Filter Changed: Yes / No

Pollen Filter Changed: Yes / No

Spark Plugs Changed: Yes / No

Anti Corrosion Inspection: Yes / No

Fluids Changed:

Additional Service Information

140,000 Miles or 14th Year

Odometer:

Technician Name:

Date:

Next Service Due:

Authorised Dealer Stamp

Service Advisor Name:

Service Advisor Signature:

Service Details

Service Actions Checked: Yes / No

Air Filter Changed: Yes / No

Pollen Filter Changed: Yes / No

Spark Plugs Changed: Yes / No

Anti Corrosion Inspection: Yes / No

Fluids Changed:

Additional Service Information

150,000 Miles or 15th Year

Odometer:

Technician Name:

Date:

Next Service Due:

Authorised Dealer Stamp

Service Advisor Name:

Service Advisor Signature:

Service Details

Service Actions Checked: Yes / No

Air Filter Changed: Yes / No

Pollen Filter Changed: Yes / No

Spark Plugs Changed: Yes / No

Anti Corrosion Inspection: Yes / No

Fluids Changed:

Additional Service Information

160,000 Miles or 16th Year

Odometer:

Technician Name:

Date:

Next Service Due:

Authorised Dealer Stamp

Service Advisor Name:

Service Advisor Signature:

Service Details

Service Actions Checked: Yes / No

Air Filter Changed: Yes / No

Pollen Filter Changed: Yes / No

Spark Plugs Changed: Yes / No

Anti Corrosion Inspection: Yes / No

Fluids Changed:

Additional Service Information

170,000 Miles or 17th Year

Odometer:

Technician Name:

Date:

Next Service Due:

Authorised Dealer Stamp

Service Advisor Name:

Service Advisor Signature:

Service Details

Service Actions Checked: Yes / No

Air Filter Changed: Yes / No

Pollen Filter Changed: Yes / No

Spark Plugs Changed: Yes / No

Anti Corrosion Inspection: Yes / No

Fluids Changed:

Additional Service Information

180,000 Miles or 18th Year

Odometer:

Technician Name:

Date:

Next Service Due:

Authorised Dealer Stamp

Service Advisor Name:

Service Advisor Signature:

Service Details

Service Actions Checked: Yes / No

Air Filter Changed: Yes / No

Pollen Filter Changed: Yes / No

Spark Plugs Changed: Yes / No

Anti Corrosion Inspection: Yes / No

Fluids Changed:

Additional Service Information

190,000 Miles or 19th Year

Odometer:

Technician Name:

Date:

Next Service Due:

Authorised Dealer Stamp

Service Advisor Name:

Service Advisor Signature:

Service Details

Service Actions Checked: Yes / No

Air Filter Changed: Yes / No

Pollen Filter Changed: Yes / No

Spark Plugs Changed: Yes / No

Anti Corrosion Inspection: Yes / No

Fluids Changed:

Additional Service Information

200,000 Miles or 20th Year

Odometer:

Technician Name:

Date:

Next Service Due:

Authorised Dealer Stamp

Service Advisor Name:

Service Advisor Signature:

Service Details

Service Actions Checked: Yes / No

Air Filter Changed: Yes / No

Pollen Filter Changed: Yes / No

Spark Plugs Changed: Yes / No

Anti Corrosion Inspection: Yes / No

Fluids Changed:

Additional Service Information



ASTON MARTIN



ASTON MARTIN



ASTON MARTIN

Aston Martin Warranty

Vehicle Warranties.....	B.2	Consumer Law.....	B.7
Warranty Period.....	B.3	Owner Details.....	B.8
Who May Repair the Vehicle.....	B.3	Vehicle Details.....	B.8
Wear and Tear Items.....	B.4	Owner Warranty Transfer (3).....	B.9
What is Not Covered.....	B.5	Owner Warranty Transfer (2).....	B.9
Customer Responsibility.....	B.6	Owner Warranty Transfer (1).....	B.9
Warranty Coverage when Touring.....	B.7	Owner Warranty Transfer (6).....	B.11
Aston Martin Extended Warranty.....	B.7	Owner Warranty Transfer (5).....	B.11
		Owner Warranty Transfer (4).....	B.11



Vehicle Warranties

Aston Martin gives a Warranty for each new Aston Martin vehicle and each replacement vehicle or assembly manufactured or supplied by the Company to be free from defects in material and workmanship under normal use and service for the applicable Warranty period.

The warranties provided herein are for the benefit of the original purchaser and any subsequent owner during the relevant Warranty Period (defined below) in the Serviced Countries (defined below).

An Aston Martin vehicle is built and homologated to support the Region for which it is manufactured and is compliant with the local regulatory requirements of that Region. As a result, the warranties cover Aston Martin vehicles that are built for and supplied to the Region.

For the purposes of this Owner's Guide, Region means one of the following territories:

- the Americas, including the United States, Canada, and South America; or
- the United Kingdom, Europe, Russia and South Africa; or
- the Middle East, North Africa and India; or
- Asia Pacific, including China, Japan, Taiwan, Hong Kong, Singapore, Australia and New Zealand.

'**Serviced Countries**' means either: (a) any country in the Region from which your Aston Martin vehicle was purchased, where there is an Aston Martin authorised dealer or repairer; or (b) any country agreed in writing with Aston Martin.

 *Tyres are covered separately by the tyre manufacturer. Dealers are expected to offer assistance to the customer in pursuing a claim against the tyre manufacturer.*

Exchange Parts Under Warranty

New parts will only be used for repairs at PDI and during the first three months or 5000 km/3000 miles (which ever occurs first) from the date the vehicle is handed over to the first retail customer. Thereafter exchange parts must be used where available under Aston Martin's exchange plan.

Anti Perforation Corrosion Protection Warranty

The vehicles bodywork is protected by an Anti Perforation Corrosion Warranty. Should any part of the bodywork of the Aston Martin vehicle be perforated, the panel(s) affected by the perforation will be repaired or replaced.

The term 'perforation' means a hole that penetrates through a body panel from the inside.

Warranty Period

The period of cover for all types of warranty commences on the day the vehicle is handed over to the first registered keeper of the car (first registered keeper shall mean the Dealer in the context of demonstration vehicles).

The Vehicle Warranty period of cover is three years with unlimited mileage.

The Anti Perforation Corrosion Warranty period of cover is ten years with unlimited mileage.

Who May Repair the Vehicle

Franchise Holders or Approved Repairers, who are appointed and receive full technical support from Aston Martin, provide facilities for the servicing and repair of Aston Martin motorcars. Only such Franchise Holders or Approved Repairs will under the terms of this warranty, repair replace or readjust, free of charge to the owner, any part or assemble proved to Aston Martins satisfaction to show a defect in materials or workmanship within the applicable period.

Wear and Tear Items

Items that are subject to wear and tear are generally divided into two categories, namely those specified for replacement or adjustment during scheduled maintenance and those that require replacement or adjustment dependent upon conditions of use.

Scheduled Maintenance Items

The items listed below are covered by the Vehicle Warranty up to the first scheduled change point that replacement or adjustment is required during scheduled maintenance operations. The customer literature supplied with the new Vehicle includes a service book setting out such scheduled maintenance operations.

- Drive belts
- Spark plugs
- Oil, air, pollen and fuel filters.

 *The period of warranty cover for any item may not exceed the time and distance limitation of the vehicle warranty.*

Wear and Tear Items

The items listed below are recognised as having a limited service life or are subject to wear or damage. However, these items are covered by the vehicle warranty for up to one year or the first service, whichever ever occurs first.

- Wiper blades.
- All light bulbs.
HID headlamp bulbs and instrumentation illumination bulbs are covered by the full vehicle warranty.
- Wheel alignment and balancing.
- Adjustments, including but not limited to: headlamp and hinged panel adjustments, suspension tightening, steering geometry adjustments, emission and fuel systems checks and park brake cable adjustments.
- Remote handset batteries.

 *Brake pads, brake discs, clutches and other friction related components are not covered when replacement is due to wear and tear, but they are covered against manufacturing defects (whether in material or workmanship) for the duration of the Vehicle Warranty.*

Consumables

Replacement or top up of consumable fluids, e.g. oils, antifreeze, brake fluid, windscreen wash solution and refrigerant, will only be covered when they are used as part of a warranty repair.

What is Not Covered

Vehicle Warranty

Aston Martin is **not** responsible for any repair or replacement that is required as a direct result of:

- Normal wear and tear.
- Friction related components, e.g. clutch, brake pads and brake discs.
- Failure to properly maintain the vehicle in accordance with Aston Martin's maintenance schedules and service instructions.
- Failure to use Aston Martin specified parts or fluids during a warranty repair (or parts of equivalent quality during a retail repair).
- Damage resulting from neglect, accident, flooding or improper use.
- Any modification of the vehicle or parts which is not authorised by Aston Martin, including any engine performance enhancement modifications.
- Refilling or topping up with incorrect fuel, e.g. diesel instead of petrol.
- Use of bio ethanol alternative fuels.

- Use of a fuel not approved or recommended by Aston Martin in the Owner's Guide is considered misfuelling, and that any damage resulting from mis-fuelling is not covered by the vehicle warranty.
- Defects caused as a result of the vehicle being used in motor sport or track events or for any other purpose other than normal private or commercial use.
- Any vehicle that has had its vehicle identification number altered or removed, or on which the odometer reading has been unlawfully altered.

Paint Surface and Corrosion Protection

Aston Martin is not responsible for any repair or replacement that is required as a direct result of the following:

- Failure to properly maintain paint and bodywork by regular cleaning in accordance with Aston Martin instructions.
- Factors beyond Aston Martin's control, such as environmental hazards (including industrial fallout, storm damage, acid rain) and damage (including stone chips, scratches and use of unsuitable cleaning agents).
- Accident repairs using materials or methods of repair that have not been approved by Aston Martin.
- Alterations of the vehicle from Aston Martin's original specification.
- Failure to rectify on a timely basis any paint or corrosion damage as recorded in the vehicle documentation by a dealer at the time of the annual inspection.

Other Exclusions

The Aston Martin warranty excludes liability for any lost time, inconvenience, loss of transportation, or any other incidental or consequential damage you (or anyone else) may incur as a result of a defect covered by this warranty.

Customer Responsibility

The customer literature will describe the proper care and use of the vehicle. Proper maintenance and use guard against major repair expenses resulting from misuse, neglect or inadequate maintenance, and may help increase the value that the customer may receive when selling the vehicle.

The Customer is responsible to:

- Make sure that the vehicle is maintained in accordance with the vehicle service and maintenance guide published in the customer literature.
Failure to perform maintenance promptly and in accordance with Aston Martin's specified service intervals will invalidate warranty coverage on the parts affected.
- The customer is required to take the vehicle to a dealer for any warranty repairs as soon as practicable after a defect is detected.

- Make sure that the Service and Maintenance schedule has been stamped by the servicing dealer after the completion of a scheduled service operation.
- Make sure that paint and bodywork is maintained by regular cleaning in accordance with the vehicle manufacturer's instructions.
- Make sure that the body panels are examined annually by an authorised Aston Martin Dealer and that this inspection is recorded in the Owner's Guide.

Warranty Coverage when Touring

Aston Martin has a comprehensive service network in most parts of the world. Any authorised Aston Martin Dealer can carry out repairs under the terms of the vehicle warranty. Under normal circumstances, the customer should not be required to pay for any warranty work performed by an Aston Martin Dealer.

It is the customer's responsibility to produce the warranty documentation issued with the new vehicle. This establishes the customer's right to warranty coverage and the relevant maintenance and service records. If the customer is unable to do so, the dealer should seek advice from Aston Martin.

Aston Martin Extended Warranty

Aston Martin Extended Warranty is specifically designed to provide the customer with first class after-sales protection from unexpected repair costs when the vehicle warranty has expired, and the knowledge that your Aston Martin will be repaired by trained technicians using only genuine Aston Martin parts.

Contact your Aston Martin Dealer for more information on the benefits and protection provided by the Aston Martin Extended Warranty.

Consumer Law

The Warranty is a manufacturer's warranty that supplements and does not affect the Owner's legal rights under the vehicle purchase agreement or under applicable national legislation governing the sale of consumer goods.

Owner Details**Name:****Address:**

:

:

:

Post Code:

Signature:

Date:

Dealer Stamp**Vehicle Details****Registration Plate No.:****VIN No.:****Engine No.:****Warranty Start Date:**

If the vehicle is sold, the benefits of any un-expired portion of the warranties can be transferred to the new owner.

The new owner should complete a 'tear off' sheet (next page) and send the new details to:

Aston Martin Warranty Department

Aston Martin Lagonda Limited

Banbury Road

Gaydon

Warwick

CV35 0DB

England

Owner Warranty Transfer (3)**Owner Warranty Transfer (2)****Owner Warranty Transfer (1)**

VIN No.:

VIN No.:

VIN No.:

Odometer:

Odometer:

Odometer:

Date of Purchase:

Date of Purchase:

Date of Purchase:

Name:

Name:

Name:

Address:

Address:

Address:

:

:

:

:

:

:

:

:

:

Post Code:

Post Code:

Post Code:

Telephone No.:

Telephone No.:

Telephone No.:

Email Address:

Email Address:

Email Address:

Signature:

Signature:

Signature:

Date:

Date:

Date:



ASTON MARTIN



ASTON MARTIN



ASTON MARTIN

Owner Warranty Transfer (6)

VIN No.:

Odometer:

Date of Purchase:

Name:

Address:

:

:

:

Post Code:

Telephone No.:

Email Address:

Signature:

Date:

Owner Warranty Transfer (5)

VIN No.:

Odometer:

Date of Purchase:

Name:

Address:

:

:

:

Post Code:

Telephone No.:

Email Address:

Signature:

Date:

Owner Warranty Transfer (4)

VIN No.:

Odometer:

Date of Purchase:

Name:

Address:

:

:

:

Post Code:

Telephone No.:

Email Address:

Signature:

Date:



ASTON MARTIN



ASTON MARTIN



ASTON MARTIN

Aston Martin Assistance

Emergency Assistance	C.2
Benefits	C.3
Alternative Travel Arrangements	C.4
What To Do In An Emergency	C.7
European Autoroute Restrictions	C.8
What is not Covered	C.8
Schedule - Eligible Vehicles	C.11

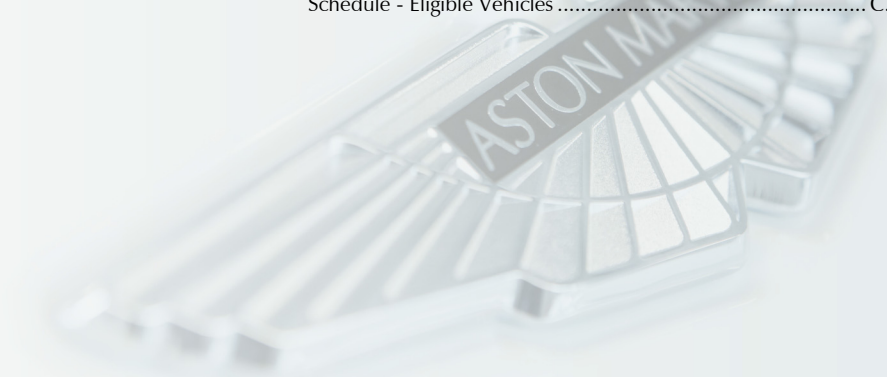

Emergency Assistance

As the owner of an Aston Martin vehicle you should enjoy a high standard of trouble free motoring. However, should the unexpected occur, our worldwide Dealer network is there to help you. Details and contact telephone numbers are shown in the Dealer Directory. In the UK and specific countries within Europe, a special additional emergency service, known as '**Aston Martin Emergency Assistance**', has been designed to provide you and your passengers with the help you need quickly and efficiently should your vehicle suffer a Breakdown Incident ¹.

Vehicles Covered

The benefits of Aston Martin Emergency Assistance are applicable to new and / or used Aston Martin vehicles purchased from an authorised Aston Martin Dealer. Refer to www.astonmartin.com for a list of all authorised Aston Martin Dealers.

At completion of your purchase, your Aston Martin Dealer will register your vehicle for Aston Martin Emergency Assistance. From registration, your vehicle will be entitled to Aston Martin Emergency Assistance (the '**Vehicle**'). For more details of what constitutes an eligible Vehicle, please refer to the Schedule.

An eligible Vehicle is entitled to receive Aston Martin Emergency Assistance for a period of 36 months from the date of registration with the service provider. Owners of eligible Vehicles can also obtain Aston Martin Emergency Assistance when travelling temporarily outside their Country ², within Europe.

Europe is defined as:

Andorra, Austria, Belgium, Bosnia-Herzegovina, Bulgaria, Crete, Croatia, Czech Republic, Denmark, Estonia, Finland, France, Germany, Gibraltar, Greece, Hungary, Italy, Latvia, Liechtenstein, Lithuania, Luxembourg, Monaco, Netherlands, Norway, Poland, Portugal (not Madeira), Republic of Ireland, Romania, Russia, San Marino, Slovakia, Slovenia, Spain (including the Balearic Islands and Canary Islands), Sweden, Switzerland, Turkey (European Part), Ukraine, and Vatican City.

United Kingdom (UK) is defined as:

England, Scotland, Wales, Northern Ireland, Channel Islands and Isle of Man.

¹ A **Breakdown Incident** means an event where an eligible Vehicle is immobilised due to a breakdown in circumstances where it qualifies for Aston Martin Emergency Assistance, including home-starts or broken glass. Furthermore, Aston Martin Emergency Assistance covers you in the event of safety-related defects, which render the Vehicle illegal to drive. These defects relate to, for example, failure of the seat belts, windscreen wipers, direction indicators, front and rear lamps.

² '**Country**' means the country in which your Vehicle is registered.

Benefits

The service provider, appointed by Aston Martin to provide the Aston Martin Emergency Assistance services (the 'Service Provider') will provide the following benefits dependent on requirements to entitled Vehicles in both the home Country and Europe as defined.

Roadside Assistance

The Service Provider's Agent vehicle should promptly arrive with you after your call has been placed. You may also book an appointment for a convenient time.

Aston Martin Emergency Assistance shall provide you with updates on its estimated time of arrival via your preferred communication method.

If following a Breakdown Incident in an area of coverage, your journey cannot be completed, and where the Vehicle cannot be repaired at the roadside, Aston Martin Emergency Assistance shall organise recovery of the Vehicle, including any luggage contained in the Vehicle at the time. Your Vehicle and luggage shall be transported to the nearest Aston Martin Dealer, without distance or financial limitation.

If the Vehicle cannot be repaired at the roadside or at your home address within a reasonable time period (45 minutes), the Service Provider will take you, the Vehicle and your passengers to the nearest Aston Martin Dealer. In the event that you (or your passengers) need to keep an important appointment, you will be taken there before the disabled Vehicle is transported to its required destination.

Should the Breakdown Incident occur outside of workshop hours, Aston Martin Emergency Assistance shall arrange for secure storage of the Vehicle until the next working day. The Vehicle shall arrive at the Dealer by midday on the next day.

If the nearest Dealer, to where the eligible Vehicle has been towed, is able to carry out the repairs at its premises, then the Vehicle will be repaired there.

Once the Vehicle is at a Dealership for repair, Aston Martin Emergency Assistance will keep in contact with the Dealer to follow the progress of the repair, and if necessary, arrange any extension of a replacement vehicle with Aston Martin Customer Service.

Home Start

Aston Martin Emergency Assistance will provide all the benefits of Roadside Assistance at the Vehicle's registered address.

Recovery

If Aston Martin Emergency Assistance cannot repair your Vehicle at the roadside, the Service Provider will arrange recovery of you and your Vehicle to the nearest Aston Martin Dealer.

If your Vehicle has been involved in an accident or has gone off the road and needs to be salvaged before towing, Aston Martin Emergency Assistance will charge you for services on a 'Pay for Use' basis and you may be able to claim these back from your insurance company.

You will be covered for costs of recovery and towing (including any handling fee) but you may be charged for any costs incurred if the Vehicle is, for example, disabled by floods or snow-affected roads, is embedded in sand or mud, or is not easily accessible.

If your Vehicle cannot be repaired and / or recovery is initiated to an Aston Martin Dealer, the Service Provider will provide alternative travel options for you. You will be entitled to receive one of the following additional services:

- A replacement vehicle for up to two working days in your Country, or 14 days if the Breakdown Incident occurs outside your Country (a collection and delivery service, or equivalent, is available from chosen suppliers subject to availability and supplier's terms and conditions);
- Onward transportation;
- Overnight accommodation.

Vehicle Collection Following Repair

Following repairs organised by Aston Martin Emergency Assistance, the cost of a first class rail ticket or (if rail transport would normally exceed six hours) a business class air ticket will be met to permit you or a person you designate to collect the repaired Vehicle. Alternatively, arrangements can be made for your Vehicle to be returned to your home or business address, whichever is the nearest to the repairing Dealer. Alternative addresses closer to the repairing Dealer may also be considered.

Alternative Travel Arrangements

If the Service Provider estimates that the repairs to your Vehicle will take more than eight hours, the Aston Martin Emergency Assistance will cover your reasonable costs for alternative necessary travel, including for members of your party.

Reasonable additional expenses shall be covered for one or a combination of the following:

- Replacement vehicle costs to a maximum of two working days in your Country and up to 14 days outside your Country.
- Air fares (business class ticket).
- Rail fares (first class ticket).
- Local taxi fares.
- Any other transport equivalent to first class rail fares.

Replacement Vehicle

If following a Breakdown Incident:

- Your Vehicle is immobilised.
- Roadside repairs are unsuccessful.
- If repair of the Vehicle is not possible within the same day after towing to the Dealer.

Aston Martin Emergency Assistance will organise free of charge, a replacement vehicle for you until completion of the repairs. The replacement vehicle will include fully comprehensive insurance ¹, with an option to upgrade to include collision damage waiver.

The loan of this replacement vehicle will not exceed two working days (in your Country) or, if the Breakdown Incident occurred outside your Country, 14 days plus two working days after your return to your home country.

Aston Martin Emergency Assistance aim to make sure that the replacement vehicle is a suitable vehicle for you. Specially adapted replacement vehicles will not be provided.

The replacement vehicle will be delivered to you, where possible, but if you prefer, taxi costs for collecting the replacement vehicle, will be met by Aston Martin Emergency Assistance.

You will be responsible for fuelling and basic maintenance of the replacement vehicle, while under your care. You will also be responsible for paying any deposit required by the vehicle Hire Company.

Once the repair on your Vehicle is complete, the replacement vehicle will then either be returned to the vehicle Hire Company or collection will be arranged where possible, at your request.

If the replacement vehicle has been kept beyond the term of the permitted loan period (as noted above), you will be responsible for any additional charges incurred for the extended period. If you cannot fulfil the nominated vehicle Hire terms and conditions, or circumstances prevent you from qualifying to hire the vehicle, and alternative mobility arrangements are more appropriate, then onward travel arrangements or hotel accommodation will be provided instead. The vehicle hire agreement will be between you and the relevant supplier and will be subject to that supplier's Terms and Conditions. These will usually require or include (amongst other things):

- Production of a full driving licence valid at the time of issue of the hire vehicle.
- Limits on acceptable endorsements.
- Limitations on the availability and, or engine capacity of the replacement vehicle.
- A deposit, e.g. for fuel.
- Drivers to be aged at least 21 years depending on Country, and to have held a full driving licence for at least 12 months.

¹. Unless the driver is under 21 years of age, where there may be an additional charge incurred.

Onward or Home Journey

If following a Breakdown Incident that occurs more than 80 km (50 miles) from your place of residence, your Vehicle cannot be repaired at the roadside on the same day of the Breakdown Incident, Aston Martin Emergency Assistance will cover:

- The costs of the journey from the place of the Breakdown Incident to the nearest Dealer.
- The costs of a replacement vehicle as outlined above.
- Where necessary, taxi costs for one journey to the nearest accessible train station or airport, for you and your passenger(s).
- Where necessary, the costs of a first class train journey for you and your passenger(s). If the train journey exceeds six hours, the cost of a scheduled flight (Business Class) for you and your passenger(s).

Aston Martin Emergency Assistance will reimburse you for reasonable costs incurred relating to the above, upon receipt of a claim letter from you, detailing the circumstances of the claim, along with receipts for all transport costs claimed. All claim letters must be directed to Aston Martin Emergency Assistance at Aston Martin Customer Service, Aston Martin Lagonda Limited, Banbury Road, Gaydon, Warwick, CV35 0DB. Only costs directly connected with the Breakdown Incident will be covered.

The refund process to you shall be managed by Aston Martin Emergency Assistance.

Repaired Vehicle Re-delivery

Aston Martin Emergency Assistance will attempt to contact you within 24 hours of successful repair at the Dealer in order to arrange re-delivery of the repaired Vehicle to either your home or place of work, as you request. Alternative addresses closer to the Repairing Dealer may also be considered.

Hotel

If following a Breakdown Incident that occurs more than 80 km/50 miles from your place of residence, and your Vehicle cannot be repaired at the roadside on the day of the Breakdown Incident, accommodation costs for you and your passenger(s) shall be covered for the duration of the repair, for up to a maximum of two nights if the Breakdown Incident occurs in your Country, or seven nights if the Breakdown Incident occurs outside your Country. You shall be responsible for any excess costs.

What To Do In An Emergency

Repatriation of Un-repaired Vehicle from Abroad

If the Vehicle cannot be repaired by Aston Martin Emergency Assistance within an agreed time schedule (three working days), the costs for transporting the Vehicle and its contents from the Dealer to the home Country Dealer, will be covered by Aston Martin Emergency Assistance.

Aston Martin Emergency Assistance shall arrange the safe repatriation of the Vehicle at the least cost, while respecting the need to deliver the Vehicle to the home Dealer within 14 consecutive days.

Aston Martin Emergency Assistance will cover the costs for parking the Vehicle, pending repatriation or import.

Should assistance be required in the unlikely event of a Breakdown Incident, simply contact Aston Martin Emergency Assistance using the relevant telephone number listed below.

 *It may be helpful to have the relevant telephone numbers entered into your mobile phone 'phone book'.*

00 800 28 86 28 86 ¹

+44 208 603 9875

When connected, enter the 2 digit number as prompted for your home country. Please do not make your own arrangements as Aston Martin Emergency Assistance will be not be able to reimburse you. If you are in a remote location and need assistance, the time taken to receive the assistance may be longer because of distance and local restrictions.

¹. Calls from landlines shall be free. Calls from mobile phones will be charged at standard mobile network rates.

Vehicle Identification and Location

To minimise delay, please have the following information available:

- Your name.
- Aston Martin model.
- The Vehicle Identification Number (VIN). The last six digits from the VIN label in the corner of the windscreen.
- The location of the vehicle.
- Vehicle registration number and colour.
- Telephone number where you can be contacted.
- Description of the concern experienced.

European Autoroute Restrictions

If assistance is required on a French Autoroute or on certain Autoroutes in other European countries, you must use the official SOS boxes at the side of the road in order to arrange initial assistance or recovery. You will be connected to the authorised Autoroute Assistance Service because these roads are privatised. Neither Aston Martin Emergency Assistance nor any other assistance organisations are allowed to assist on these roads.

Once your Aston Martin has been recovered from the Autoroute, you should contact Aston Martin Emergency Assistance at the earliest opportunity to make sure that any further assistance arrangements you require can be made on your behalf.

Aston Martin Emergency Assistance will advise you how to reclaim costs incurred for recovery from the Autoroute.

What is not Covered

Aston Martin Emergency Assistance is thorough and comprehensive; however, claims cannot be met as a result of any of the following:

1. Where you, or anyone else acting on your behalf, make repair or service arrangements without authorisation (and a file number) from Aston Martin Emergency Assistance.
2. Where any loss, theft, damage, death, bodily injury, cost or expense that is not directly associated with the incident that caused you to claim, unless expressly stated in this policy.
3. If the Breakdown Incident is due to fire, theft, accident or vandalism, your costs will not be covered by Aston Martin Emergency Assistance but should be met by third party insurance covering the incident.
4. Damage or injury intentionally caused by you or resulting from your participation in a criminal offence.
5. If your Vehicle is kept in an un-roadworthy condition or has not been serviced in accordance with the Manufacturer's recommendations.
6. Any costs that would have been payable by you, such as petrol, toll charges, parking fees, cost of meals, drinks, telephone calls and/ or newspapers or any other costs not specifically stated as being covered by Aston Martin Emergency Assistance, which may be incurred by you and/ or the other member(s) of your party as a result of and/ or in connection with the Breakdown Incident.
7. Release fees: Should your Vehicle be stolen and subsequently recovered by the police, you may be asked to pay a release fee before we can remove your Vehicle to an authorised Aston Martin Dealer.
8. Specialist charges: In the event that the use of specialist equipment is required to give assistance when your Vehicle has, for example, gone off the road, is in a ditch, is standing on soft ground, sand, shingle, stuck in water or snow or has been immobilised by the removal of its wheels, we will arrange recovery but you will be responsible for the costs of any specialist equipment required. The costs may be refundable under the terms of your motor insurance policy.

9. Adverse weather conditions: On those occasions when we experience adverse weather conditions, such as high winds, snow, floods, etc., external resources may be stretched and some operations become physically impossible until the weather improves. At such times, our priority is to make sure that you and your passengers are taken to a place of safety and so the recovery of your Vehicle may not be possible until weather conditions permit.

10. Customer induced breakdown incidents are not covered under Aston Martin Emergency Assistance. However, Aston Martin and the Service Provider will, at their sole discretion, assist you if you request it. However we are not obligated to provide assistance and you shall be responsible for any charges resulting from any assistance given caused by a customer induced fault. In such circumstances, a swipe card deposit may be taken by the Service Provider. Assistance in such circumstances will not include additional benefits (replacement vehicle, onward journey, hotel accommodation).

Customer induced faults may include, for example, the following:

- Lock-outs / lost keys
- Broken keys

- Discharged battery
- Running out or loss of fuel
- Use of wrong fuel (no replacement at the location of breakdown, only towing)
- Tyre damage
- Road traffic accidents.

11. Lockout / lost keys: Whilst we will always try to provide assistance by the most practical method, should you be unable to gain entry to your Vehicle, modern security systems make it extremely difficult for this to be done should spare keys not be available. If a forced entry is required, you will be asked to sign a declaration stating that you have given permission for this to take place and that any costs for resultant damage will be your sole responsibility.

12. Aston Martin Emergency Assistance shall not be required to provide services in the following circumstances:

- 12.1 In respect of Vehicles not displaying a valid road fund licence.
- 12.2 In respect of eligible Vehicles situated on private property (for example garage premises) unless you can establish to the reasonable satisfaction of Aston Martin Emergency Assistance that permission has been given by the relevant owner or occupier.
- 12.3 Vehicle servicing or re-assembly where this is required as a result of neglect or unsuccessful work on the Vehicle other than on the part of the Service Provider or its agents.
- 12.4 The recovery of any Vehicles bearing trade plates or which Aston Martin Emergency Assistance has reason to believe have just been imported or purchased at auction.
- 12.5 The transportation of immobilised Vehicles where Aston Martin Emergency Assistance considers this to be part of a commercial activity.

-
- 12.6 Assistance for Vehicles broken down as a result of taking part in any 'Motor Sport Event', including, without limitation, motor racing, rallying, speed or duration tests or practice thereof, trials or time-trials, auto test (other than auto tests performed by the Client using roadworthy, road legal cars on public roads), but excluding 'Concours d'elegance' events, track test days for road-legal Vehicles or rallies held exclusively on open public roads where participants are required to comply with the normal rules of the road (save for Aston Martin organised and controlled track day events).
- 12.7 Where the police, highways agency and / or other emergency service require that your Vehicle be recovered by a third party.
- 12.8 Where your entitlement to Aston Martin Emergency Assistance lapses or if your Vehicle is no longer considered eligible for Aston Martin Roadside Assistance, the Service Provider may charge you directly for the Services provided. Any such charges will be charged on a 'pay for use' basis and will constitute a direct contract between you and the Service Provider. If it is determined that Aston Martin is at fault for the Vehicle not being recorded as an eligible Vehicle, then Aston Martin shall pay the relevant charges.
- 12.9 Assistance for routine maintenance and running repairs of the Vehicle such as fixing faulty radios, interior light bulbs and heated rear windows.
- 12.10 For transit risk insurance, which Aston Martin Emergency Assistance recommends you take out where a Vehicle is to be repatriated.
- 12.11 Where locksmiths, body-glass or tyre specialists are required. Aston Martin Emergency Assistance will endeavour to arrange for their assistance on your behalf, however, you will be responsible for the costs of their services. Further, if use of a locksmith or other specialist would, in Aston Martin Emergency Assistance's opinion, mobilise the vehicle, no further service will be given for the breakdown in question.
- 12.12 The transportation of any animal or pets shall be at the sole discretion of the Service Provider.

Schedule - Eligible Vehicles

13. The Service Provider may charge you directly for:

- Any replacement component, lubricant and / or fuel (the 'Parts') or consumable items supplied (except where Aston Martin has provided or paid for such Parts)
- Any extension of the Services which you are entitled to receive in connection with this Agreement (which shall be performed by the Service Provider (in its absolute discretion) at your request.
- The use of any specialist lifting or towing assistance needed to recover your Vehicle if your Vehicle has gone off the road, is in a ditch, sunk in soft ground, sand or shingle or when it is stuck in snow or flood water.
- Any additional charges resulting from the failure to carry legal and serviceable spare wheel(s) or tyre(s) in the Vehicle. Aston Martin Emergency Assistance will endeavour to arrange assistance from a third party on your behalf but you will be responsible for the costs of the call out and/ or for any repair.
- The cost of garage or other labour required to repair the Vehicle, other than that provided by Aston Martin Emergency Assistance at the scene of the Breakdown Incident.

- Any costs of draining or removing fuel, lubricants or other fluids as a result of the introduction of an inappropriate substance.
 - Transportation of personal effects, goods, vehicles, boats or other waterborne craft on or in the Vehicle and any trailer or caravan. Aston Martin Emergency Assistance will not consider any claim for loss resulting from damage to / loss of use of these items. Such items remain your responsibility at all times.
14. If following a Breakdown Incident, the Service Provider, its third party garage agent or subcontractor makes a temporary repair to your Vehicle (for these purposes, a temporary repair shall mean temporary repairs of the Vehicle where the underlying cause of the Vehicle's failure is not resolved), then the Service Provider, its third party garage agent or subcontractor shall recommend you to have such temporary repair made good by a Dealer.

New Vehicles

Any Aston Martin vehicle which is sold directly by Aston Martin or a Dealer in the UK or European Territories and which is first registered in the UK or European Territories (as appropriate, (Refer to page C.2)).

Used Vehicles

Those used vehicles registered in the UK or the European Territories in respect of which an Extended Warranty has been started.

In All Cases

- Maximum Gross Vehicle Weight (including any caravans or trailers being towed at the time of the Breakdown Incident): 3500 Kg
- Maximum Vehicle Length: 5.5 m
- Maximum Vehicle Width (including any caravans or trailers being towed at the time of the Breakdown Incident): 2.3 m
- Maximum Vehicle Height: 3 m

The dimensions detailed above will be calculated taking into account anything attached to the relevant eligible Vehicle at the time of the relevant Breakdown Incident and any trailer or caravan, including but not limited to towing equipment, any carriers or racks (e.g. bike or luggage), or anything else attached to the Vehicle or the carriers / racks.

Vehicles must be built to manufacturer's specifications, display a road fund licence, and where applicable, hold a certificate of roadworthiness.



ASTON MARTIN



ASTON MARTIN

Alphabetical Index

A

Accessory Power Sockets	3.30
Adaptive Damping	5.14
Airbags	3.15
Passenger Deactivation Switch	3.19
Alarm	2.13
Movement Sensor	2.13
Reduced Guard	2.13
Tilt Sensor	2.13
Ambient Temperature	4.20
Anti-lock Braking System	5.9
Apple CarPlay	6.8
Approach Light	2.12
Ashtray and Cigar Lighter	3.30
Aston Martin Assistance	C.1
Aston Martin Tracking	2.2
Aston Martin Warranty	B.1
Audio	8.1
Battery Protection Mode	8.5
Essentials	8.2
Automatic Lock	2.11

Automatic Transmission	5.4
Fault Conditions	5.8
Touchtronic Mode	5.6

B

Battery	
Maintenance	12.19
Protection Mode	8.5
Battery Charge	12.19
Battery Conditioner	12.19
Battery Disposal	12.19
Battery Protection Mode	12.20
Bluetooth Device Management	10.3
Bonnet Release	12.7
Boot Lamps	12.25
Boot Lid	2.10
Boot Storage	3.26
Brake Pad Bedding-in	12.12
Brakes	
Anti-lock Braking System	5.9
Park Brake	5.10

C

Cabin Storage	3.28
Catalytic Converters	5.15
Child Locks	2.9
Child Safety	3.17
Child Seats	3.22
Passenger Airbag Deactivation	3.19
Climate Control	
Automatic Operation	7.5
Controls	7.2
Manual Operation	7.6
Operating Tips	7.2
Component Location	1.4
Condensation, Headlamp Units	12.25
Controls	
Centre	4.9
Information and Warning Symbols	4.6
Instrument Cluster	4.3
Stalk	4.12
Controls Overview	4.2
Cruise Control	4.19

D

Data Recording	1.5
Day Time Running	4.14
Deadlocking	2.11
Defrosting and Demisting	
Automatic	7.6
Manual	7.7
Driving Techniques	5.2
Dynamic Stability Control	5.12

E

Electric Windows	3.9
Emergency Items	12.5
Emotion Control Unit	2.5
External Lamps	12.25

F

Fluid Levels	12.8
Footbrake	5.8
Front Seat Reset	12.27
Fuel	
Catalytic Converters	5.15
Fuel Filling	5.14
Fuse Boxes	12.22

D.2

G

Garage Door Opener	2.15
Operation	2.16
Programming	2.15
Reprogramming	2.17
Rolling Code Synchronisation	2.16

H

Hands-Free Phone	10.1
Using a Phone	10.4
Headlamp	12.25
Headlamp Adjustment, Tourist,	12.26
Headlamp Condensation	12.25
Homesafe	2.12

I

Ignition Control	4.11
Immobiliser	2.14
Infotainment	
Bluetooth Pairing	6.5
Infotainment Controls	6.2
Infotainment Personalisation	6.4
Infotainment System	6.2
Power Meter	6.7

Tyre Status	6.6
Vehicle Status	6.6
Interior Mirrors	3.7
Internal Lamps	12.26

J

Jump Start From Another Vehicle	12.16
---------------------------------------	-------

L

Lamps	4.14
Boot	12.25
External	12.25
Headlamp	12.25
Internal	12.26
Locking the Vehicle	2.8
Low Outside Temperature Warning	4.8

M

Maintenance	12.1, 12.5
Vehicle Jacking	12.3
Maintenance Items	
Battery Conditioner	12.6
Tool Kit	12.6
Map	
Browse	11.7

Master Lamp	4.14	R	Brakes	13.5
Master Vehicle Lock	2.8	Reading Lamps	Bulbs	13.7
Memory Seats	3.5	Rear Seat Entertainment	Electrics	13.2
Mirrors		Replacement of Airbag Units Record	Engine	13.2
Door	3.8	Replacement of Seat Belt Pre-tensioners Record	Fluids and Capacities	13.3
Interior	3.7	Restraints System	Steering	13.4
Power Fold Function (Door Mirrors)	3.8	Determining if the System is Operational	Suspension	13.5
Reverse Dip Function (Door Mirrors)	3.8	Reversing Camera	Transmission	13.2
N		S	Tyres	13.6
Navigation		Safety Defects - Reporting	Vehicle Type	13.7
Map	11.6	Seat Belts	Wheels	13.5
Menu	11.3	Care and Maintenance	Sport Mode	5.7
Navigate	11.4	Child	Starting the Engine	5.3
POI	11.8	Seat Controls	Steering Wheel	3.7
Settings	11.10	Rear folding seats	Storage	3.26
Traffic	11.9	Seat Adjustment	Supplemental Restraints System	3.15
Navigation Controls	11.2	Seats	T	
Operation	11.2	Memory Function	Temperature Controlled Seats	3.4
P		Temperature Controlled	Track Days	5.2
Park Brake	5.10	Service Record	Traction Control	5.13
Parking Assist	5.16	Servicing	Trip	4.15
Passenger Airbag Deactivation	3.18	Servicing Precautions	Tyre	4.17
		Specifications	Tyre Sealant Kit	12.14

Tyres	12.12
Winter	12.14
U	
Unlocking the Vehicle	2.7
V	
Vehicle Battery	12.18
Vehicle Cleaning	12.28
Vehicle Horn	4.14
Vehicle Identification	1.4
Vehicle Key	2.5
Vehicle Recovery	12.16
Vehicle Storage	12.31
W	
Wheel Nut Torque	13.6
Window Reset	12.27
Windscreen Blade Replacement	12.11
Wipers	
Wiper	4.13



ASTON MARTIN



ASTON MARTIN