

PAGE	TITLE
1	CONTENTS
2	Fusebox Layouts - CEM, Engine Bay, Boot/Trunk and Underseat
3	Power Distribution - Battery, Fuseboxes, Power Outlets and Alternator
4	Power Distribution - Ignition System, including Starting
5	Power Distribution - CEM Ignition Relays (ILR, INFO, CMFT)
6	Power Distribution - Engine Fusebox Relays
7	Power Distribution - Boot/Trunk Fusebox Relays
8	Ground Distribution
9	Engine Management System - Power, Ground, Fuel, Cruise Control & Exhaust Bypass
10	Engine Management System - Engine Bank A (RHS) including Cooling Fans
11	Engine Management System - Engine Bank B (LHS)
12	Transmission - Automatic Systems and Manual Clutch Switches
13	Chassis - Braking, Steering, Stability Control
14	Chassis - Adaptive Damping, Tyre Pressure Monitoring
15	Climate Control
16	Instrument Pack
17	Exterior Lighting - Front
18	Exterior Lighting - Rear
19	Interior Lighting (BA.ILL, FADE, 2ILL)- Including Boot Latch and GDO
20	Door Mirrors and Windows - Driver & Passenger
21	Seat - Driver (shown with Sport Seat harness)
22	Seat - Passenger (shown with Lightweight Seat harness)
23	Locking and Security
24	Wash / Wipe System - including Heated Rear Screen
25	In-Car Entertainment (ICE) - Standard Multimedia Features
26	In-Car Entertainment (ICE) - Standard Audio (Alpine)
27	In-Car Entertainment (ICE) - Premium Audio (Bang & Olufsen)
28	Supplementary Restraint System
29	Driver Assist - Reverse Parking Aid System
30	Convertible Roof System (Volante Only)
31	Ancillaries - Horn, Fuel Flap Release and Glovebox Release
32	Vehicle Multiplex Systems - CAN Networks

## WIRE LABELLING

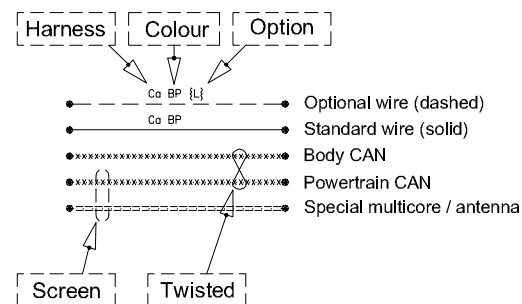

NOTE:  
Within fusebox drawings, line types are used to aid navigation and do not refer to coding shown above.

Harness Code	
Ca	Cabin
Cs	Centre stack
DfL	Door, Front, Left Hand Side
DfR	Door, Front, Right Hand Side
En	Engine
Fa	Facia (instrument panel/dashboard)
Fw	Forward (located in engine bay)
L-Bf	Link-Bumper Front
L-Br	Link-Bumper Rear
L-Fan	Link-Fan Pack
L-Ft	Link-Fuel Tank
L-Kr	Link-Key Reader (PATS)
L-Ps	Link-Power Steering
R-BI	Rear harness - Bootlid
R-Qtr	Rear harness - Rear Quarter
Tr	Transmission

Colour Code	
B	Black
O	Orange
P	Purple
G	Green
N	Brown
K	Pink
Y	Yellow
R	Red
U	Blue
S	Slate
W	White

Option Code	
Blank	No Option Code - Fitted to ALL variants
{L}	Left Hand Drive (LHD)
{R}	Right Hand Drive (RHD)
{C}	Coupe variant
{V}	Voltante (convertible) variant
{MT}	Manual Transmission
{AT}	Automatic Transmission
{AH}	Alpine Highline audio system
{BO}	Bang & Olufsen audio system
{DB9}	Features specific to DB9
{DBS}	Features specific to DBS

## WIREBREAK SYMBOLS

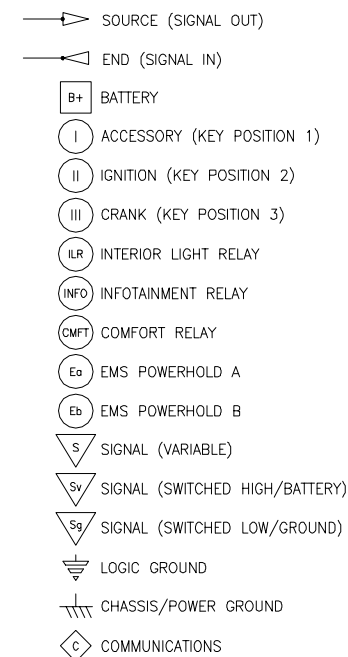

## WIREBREAK LABELLING

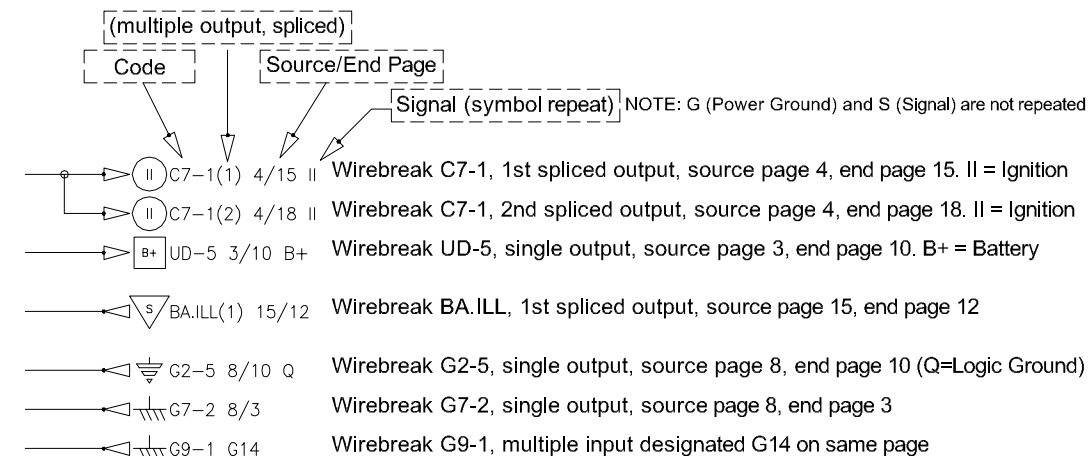

### Key Code:

- A - Engine ECU A
- B - Engine ECU B
- C - CEM, Central Electronic Module, (8 connectors #: 1, 3, 5-10)
- E - EFB, Engine Bay Fusebox (10 connectors #: 1-10)
- T - TFB, Trunk/Boot Fusebox (4 connectors #: A, B, C, D)
- U - UFB, (Rear) Underseat Fusebox (4 connectors #: A, B, C, D)
- G - Ground, either an eyelet or header (Q signifies logic ground)

## SPLICE LABELLING

- Where a splice exists only in one location, the splice name and function ARE NOT shown.
- Where a splice exists in more than one location, the splice name and function ARE shown.



CPSC Code: 00.06.51  
Prog: DB9 / DBS  
Build: 2011MY

TITLE  
SUB-SYSTEM TITLE

# CONTENTS

AML DRG No.

ILBG43-14T400-AA

1

OF 32

VIEW THROUGH LID

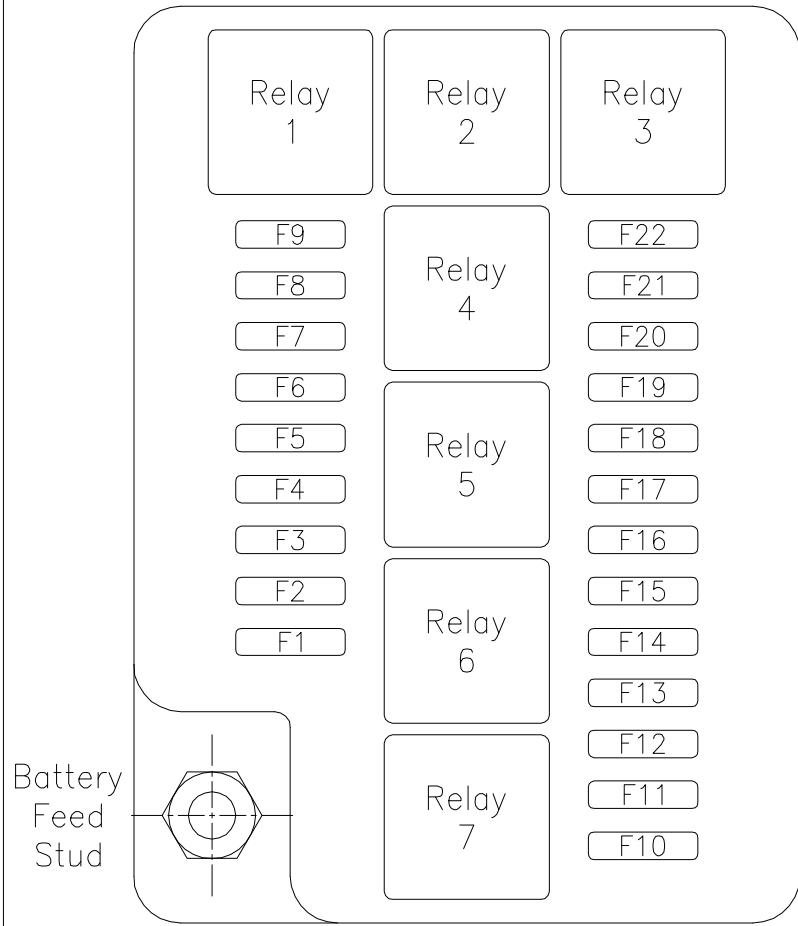

VIEW THROUGH LID

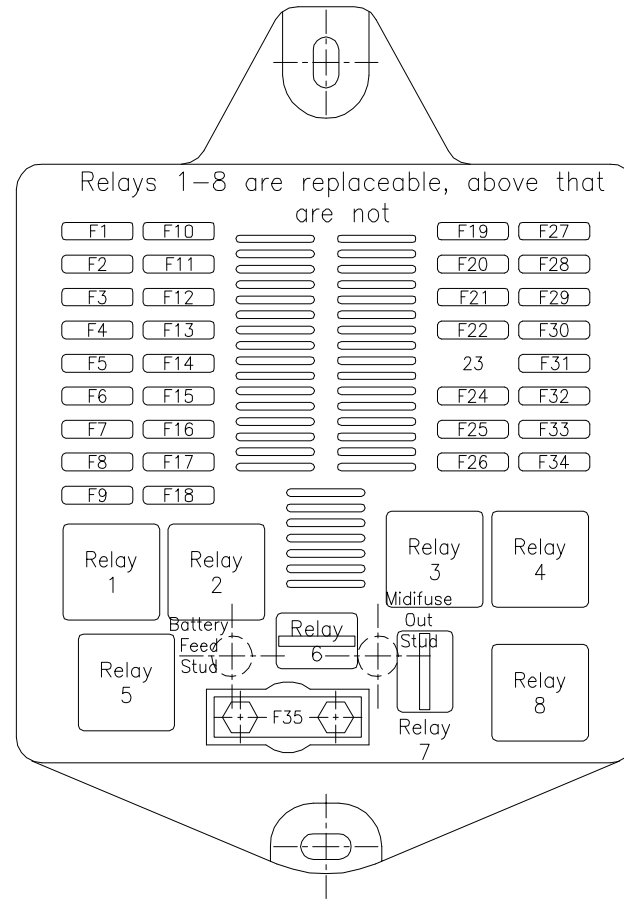

FRONT VIEW

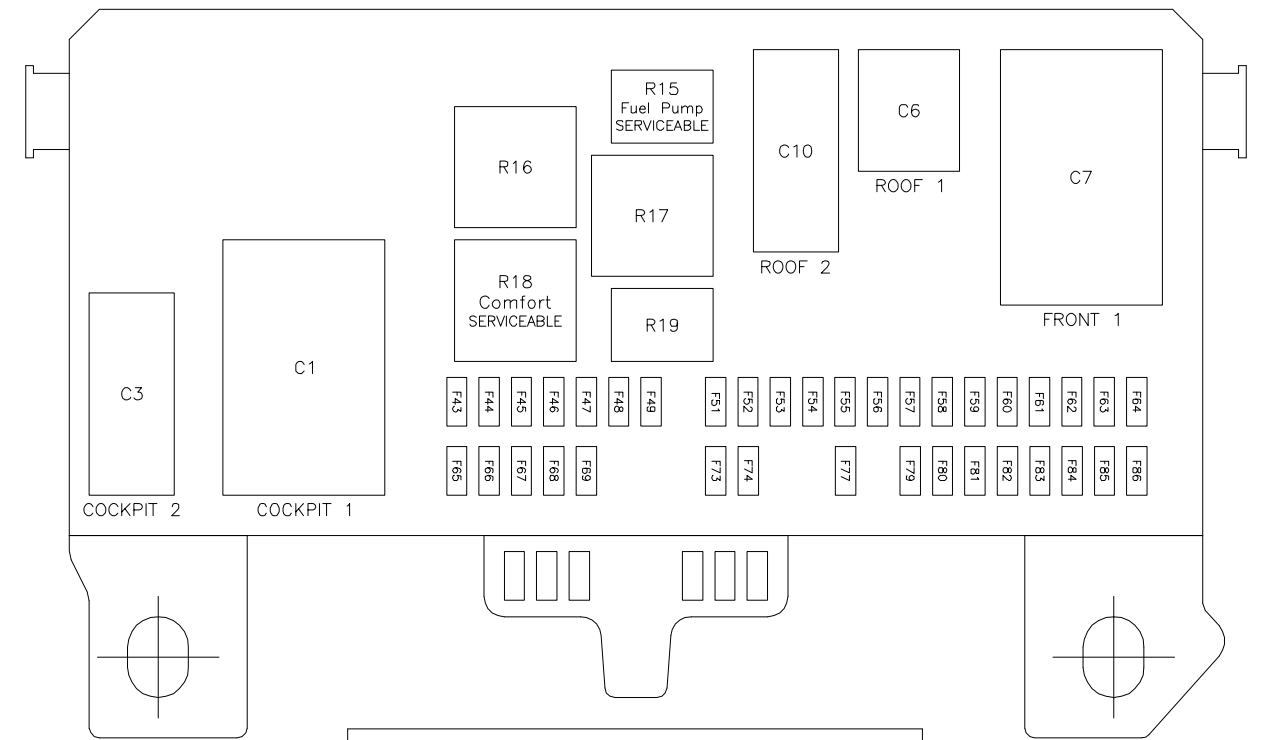

**CEM**

Connector Number	Fusebox Connector	Circuit C Number	Connector Colour
C1	Cockpit 1	C0580	BLUE
C3	Cockpit 2	C0582	BLUE
C5	Floor 1	C0584	BROWN
C6	Roof 1	C0585	BLACK
C7	Front 1	C0586	GREEN
C8	Floor 2	C0587	BROWN
C9	Front 2	C0588	GREEN
C10	Roof 2	C0589	GREY

**BOOT FUSEBOX  
4G43-14A073-AJ**

Fusebox Connector	Connector Colour	Circuit C Number
A	WHITE	C2010
B	BLACK	C2011
C	GREEN	C2012
D	BLUE	C2013

**ENGINE BAY  
FUSEBOX  
BG33-14A173-AA**

Fusebox Connector	Circuit C Number	Harness
1	C0570	Forward
2	C0571	Forward
3	C0572	Forward
4	C0573	Forward
5	C0574	Forward
6	C0575	Forward
7	C0576	Engine
8	C0577	Engine
9	C0578	Engine
10	C0579	Forward

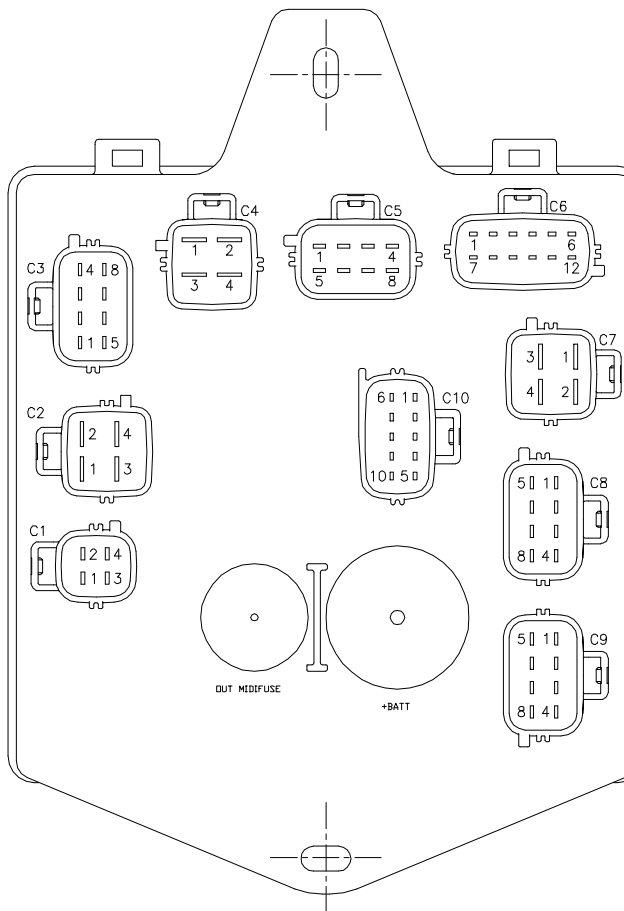

VIEW THROUGH BASE

REAR VIEW

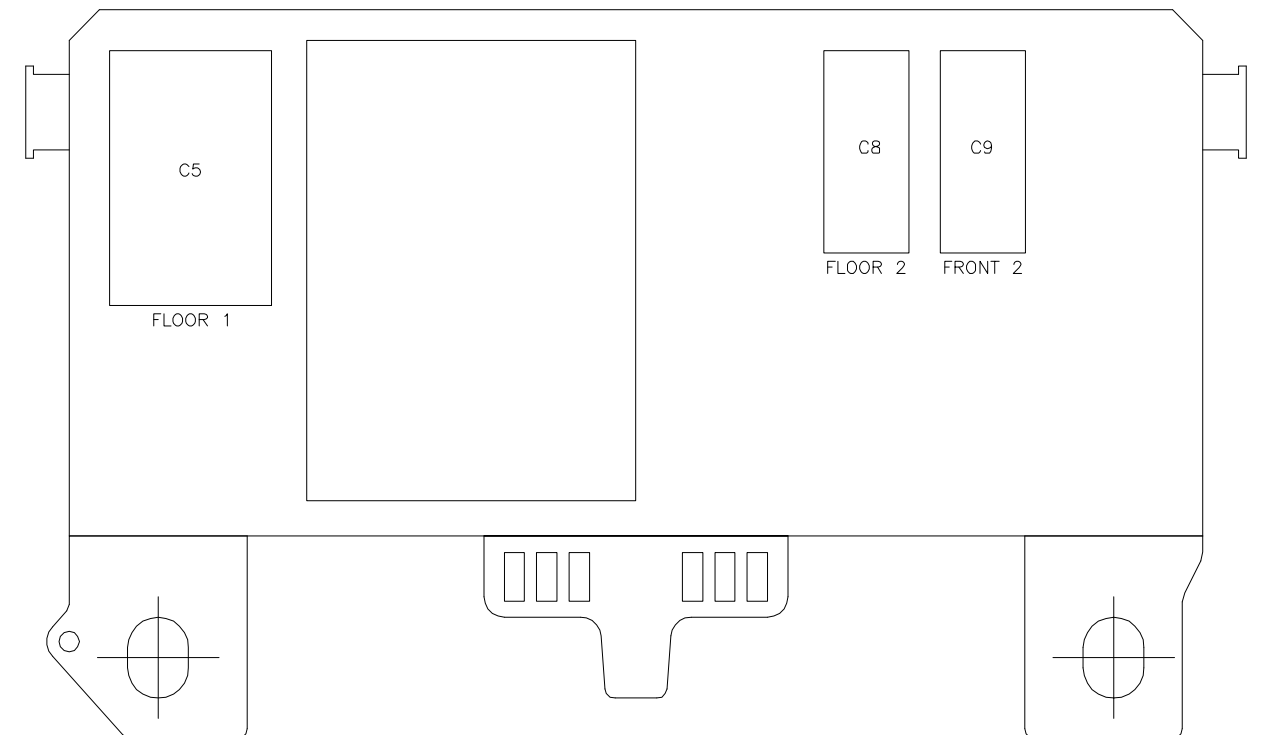

CPSC Code:  
00.06.51

Prog: DB9 / DBS  
Build: 2011MY

TITLE  
SUB-SYSTEM TITLE

**Fusebox Layout Drawings**  
Boot/Trunk, Engine Bay and CEM

AML DRG No.

**ILBG43-14T400-AA**

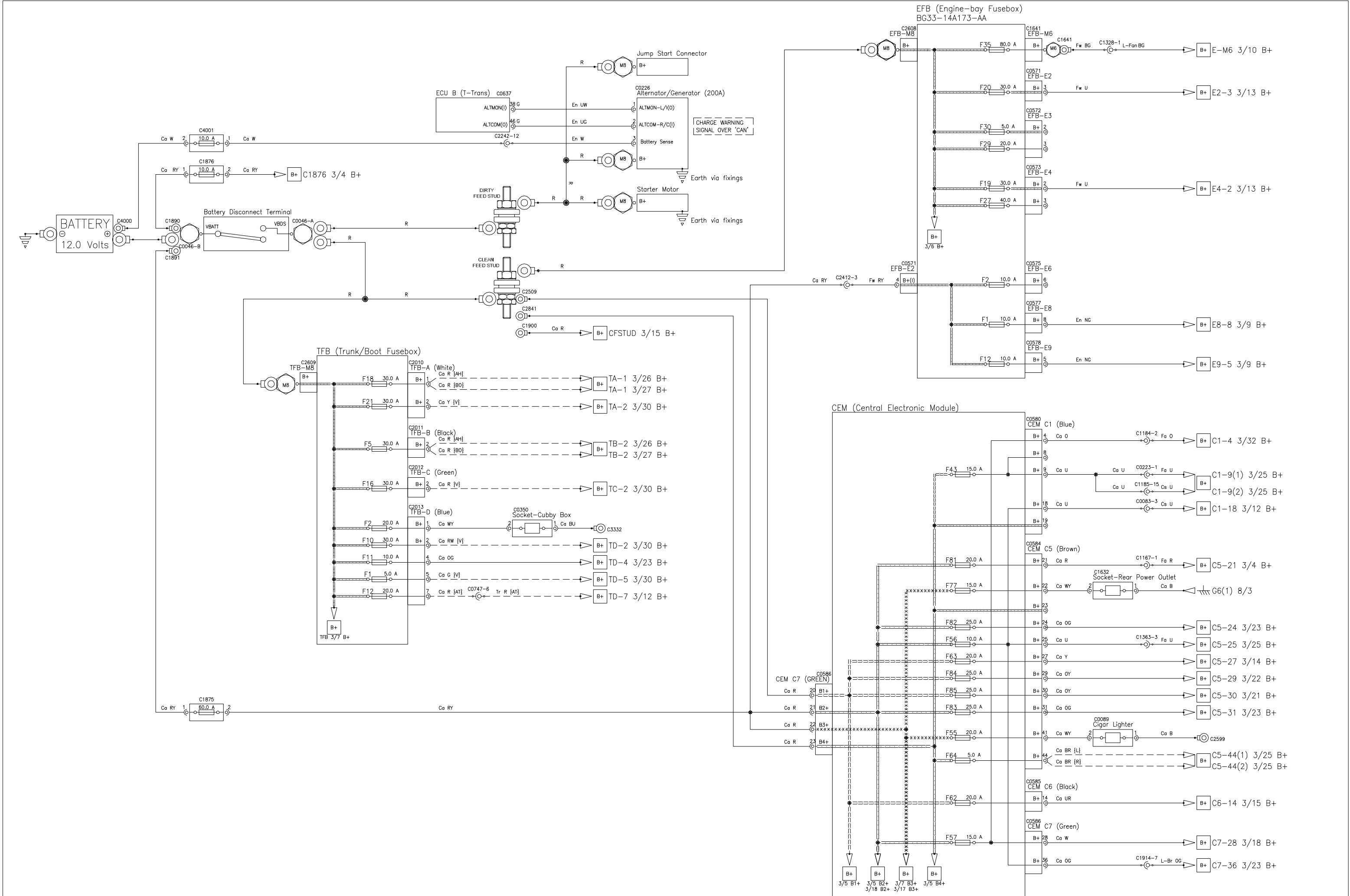

CPSC Code: 00.06.51  
 Prog: DB9 / DBS  
 Build: 2011MY

TITLE  
 SUB-SYSTEM TITLE

# Power Distribution

## Battery, Fuseboxes, Power Outlets and Alternator

AML DRG No.  
**ILBG43-14T400-AA**

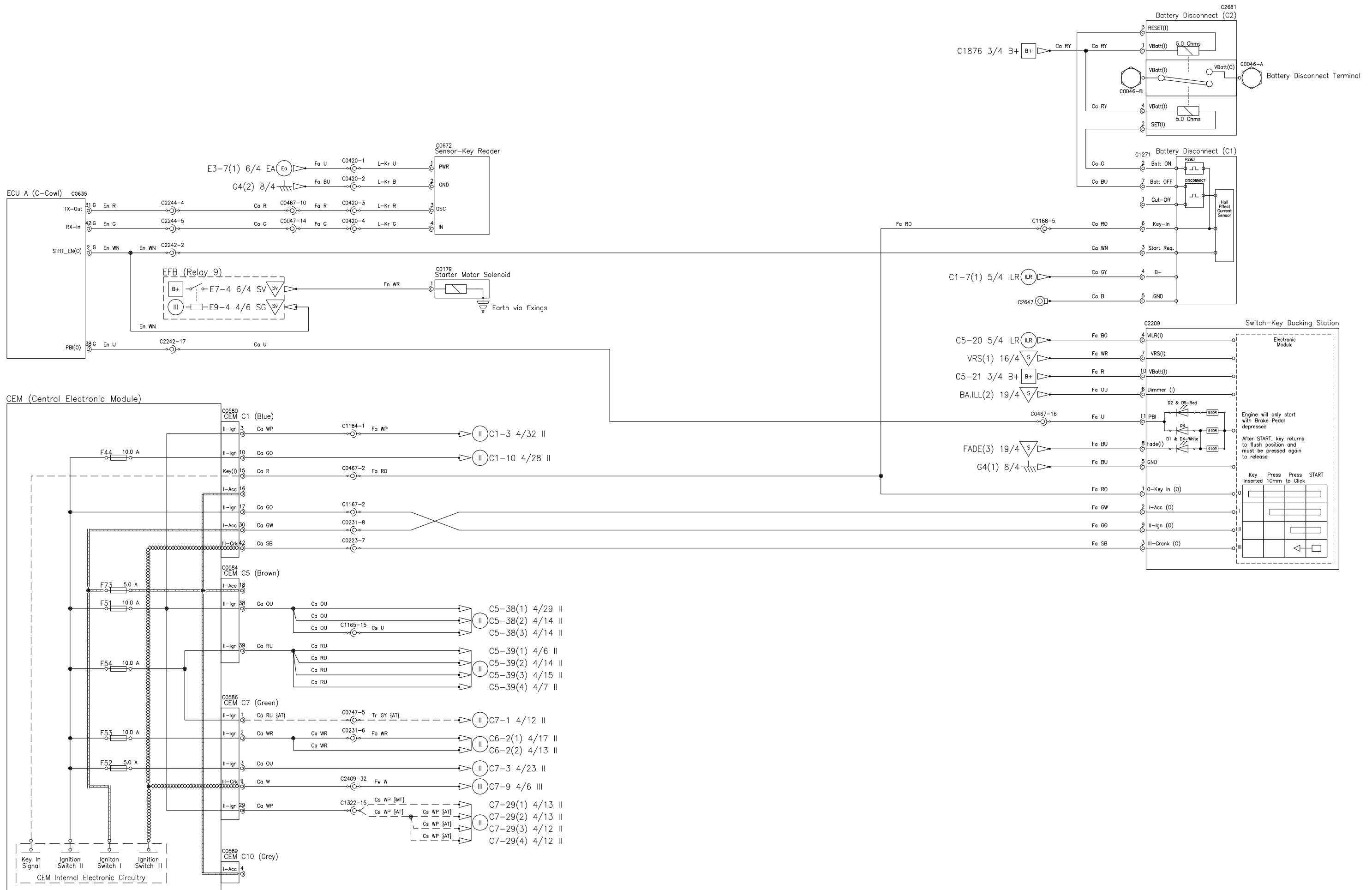

CPSC Code: 00.06.51  
 Prog: DB9 / DBS  
 Build: 2011MY

TITLE  
 SUB-SYSTEM TITLE

# Power Distribution

## Ignition System, including Starting

AML DRG No.  
**ILBG43-14T400-AA**

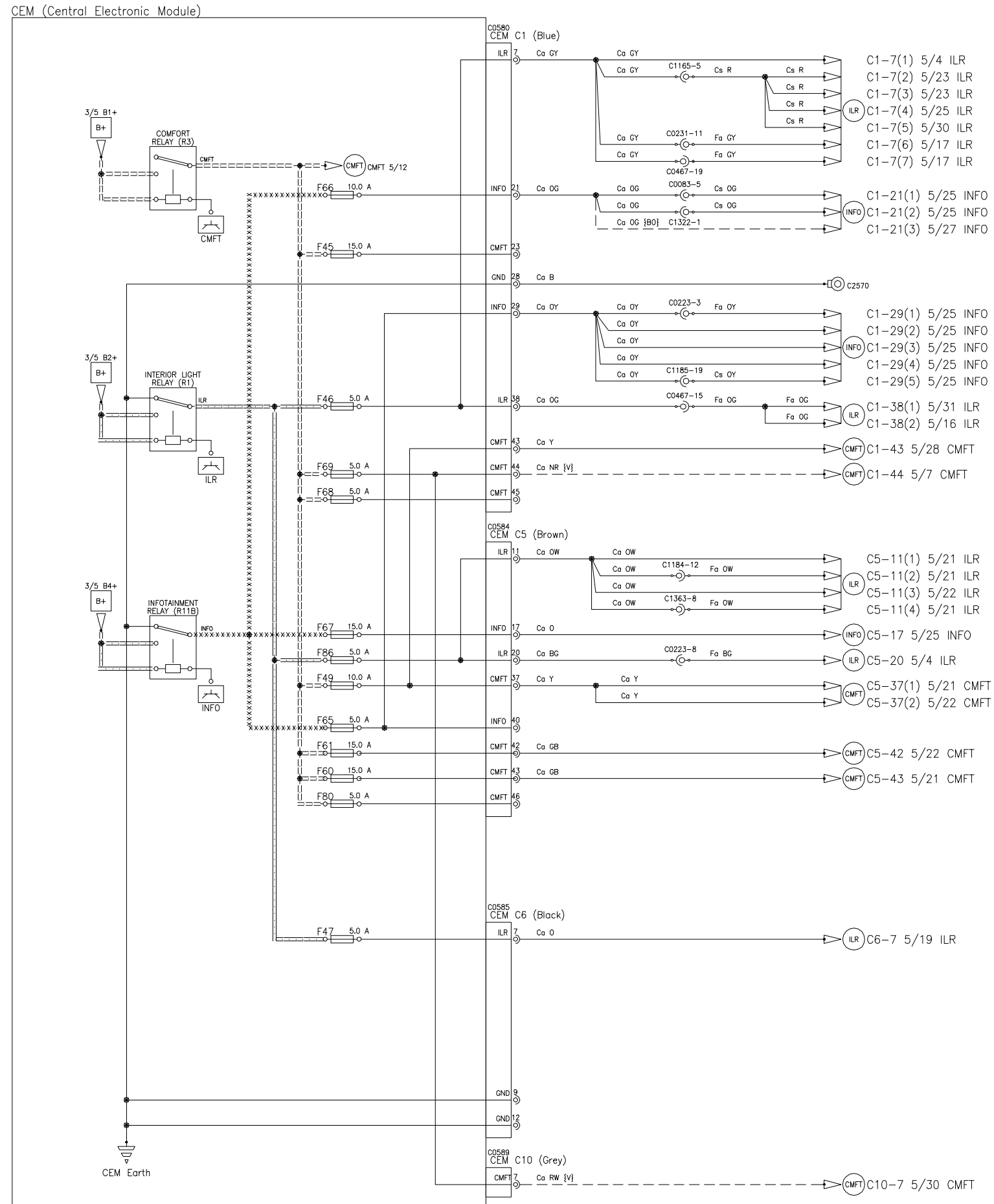

COMFORT RELAY  
 ON: with key to position II (ignition)  
 OFF: delayed 5s after Ignition OFF

INTERIOR LIGHT RELAY  
 ON: with any of the following:  
 Remote key activity  
 Brake pedal switch  
 Hazard switch  
 Door Ajar switch change (door opened or closed)  
 OFF: with either of the following:  
 Delayed 60s after Remote Key "Lock"  
 6-8minutes after Key Out

INFOTAINMENT RELAY  
 ON: with key to position 1 (accessory)  
 OFF: delayed 30s after Key Out



CPSC Code:  
 00.06.51

Prog: DB9 / DBS  
 Build: 2011MY

TITLE  
 SUB-SYSTEM TITLE

# Power Distribution

## CEM Ignition Relays (ILR, INFO, CMFT)

AML DRG No.

ILBG43-14T400-AA

5

OF 32

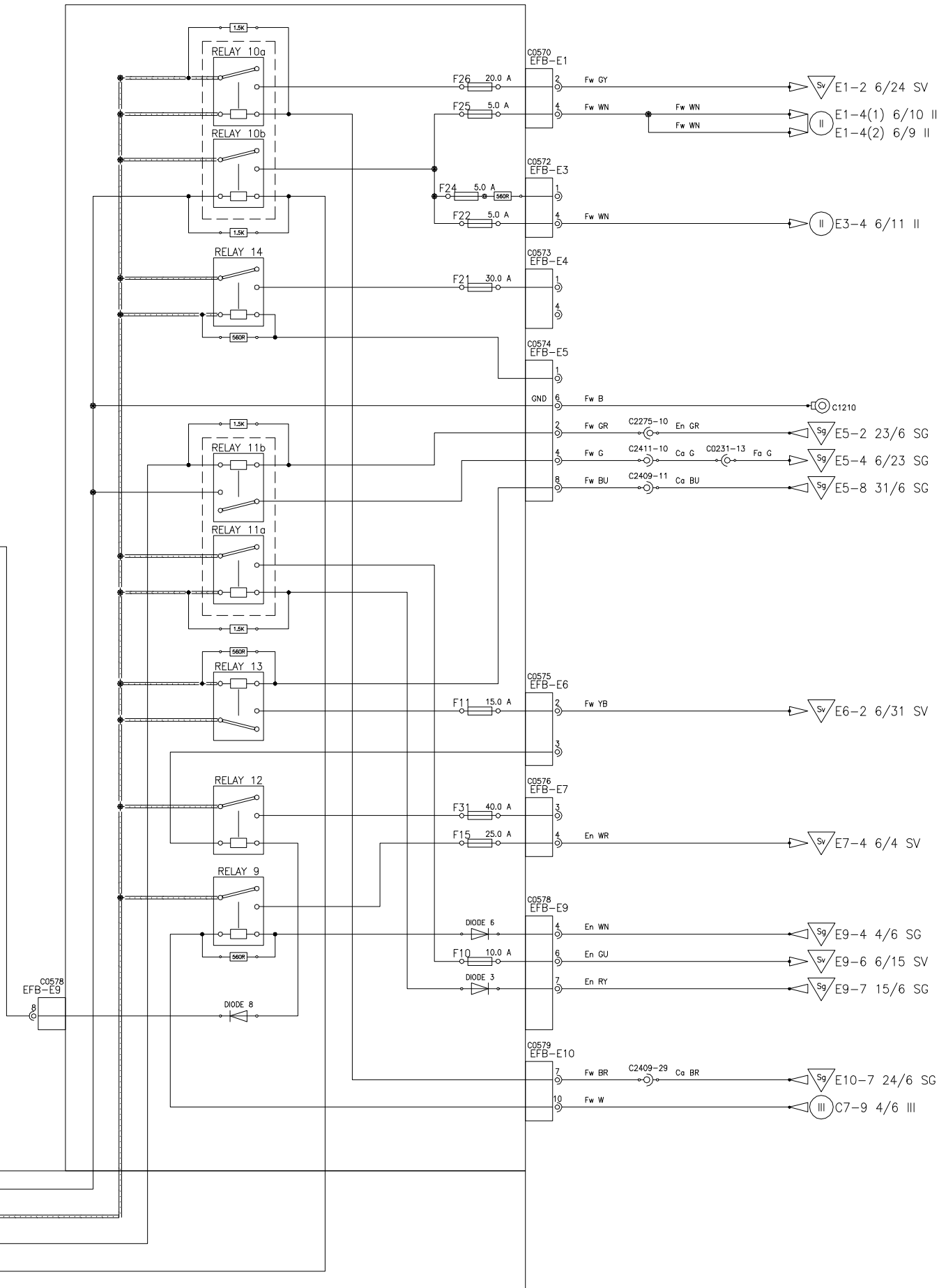
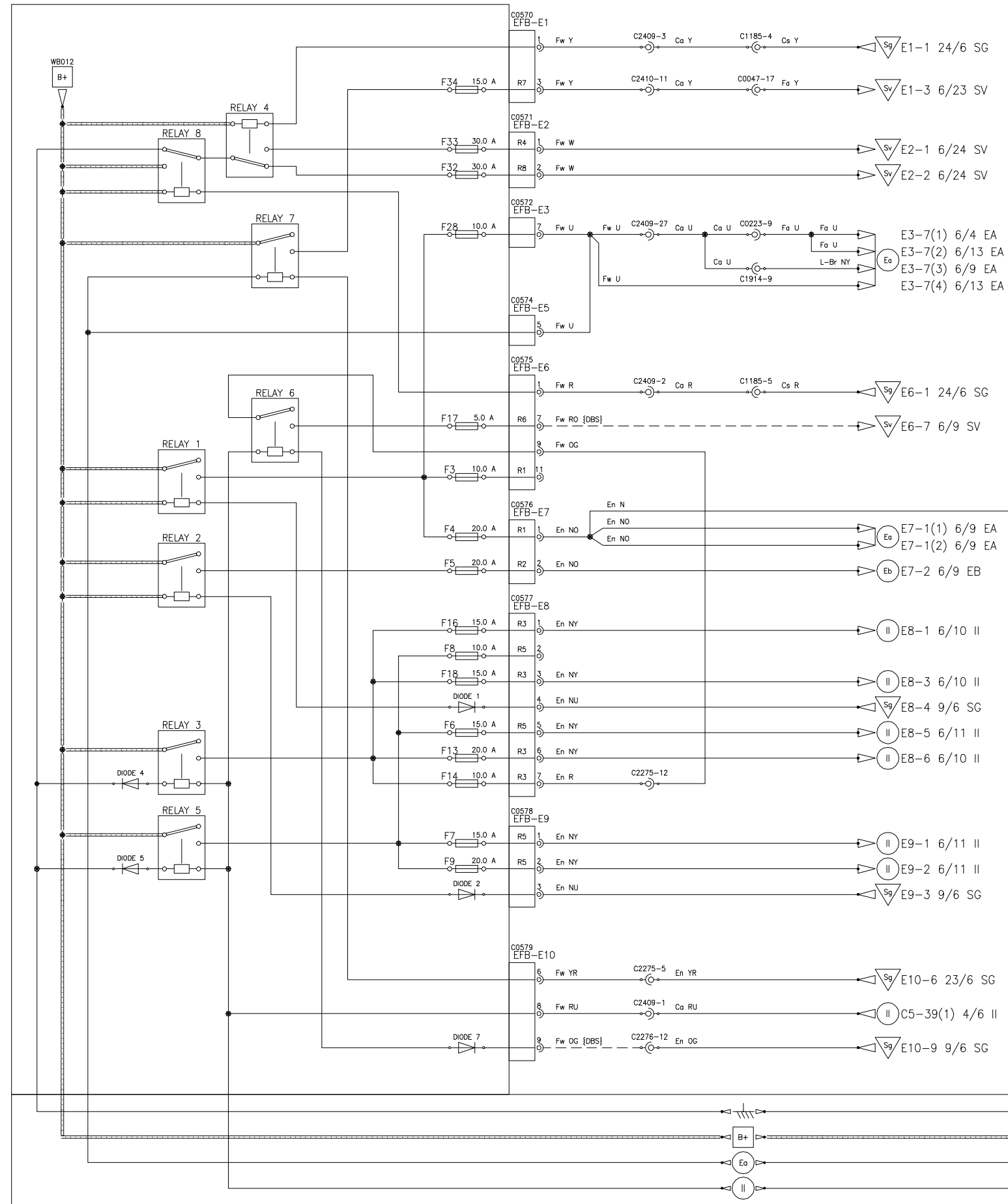

CPSC Code:  
00.06.51

Prog: DB9 / DBS  
Build: 2011MY

TITLE  
SUB-SYSTEM TITLE

# Power Distribution Engine Fusebox Relays

AML DRG No.

ILBG43-14T400-AA

6

OF 32

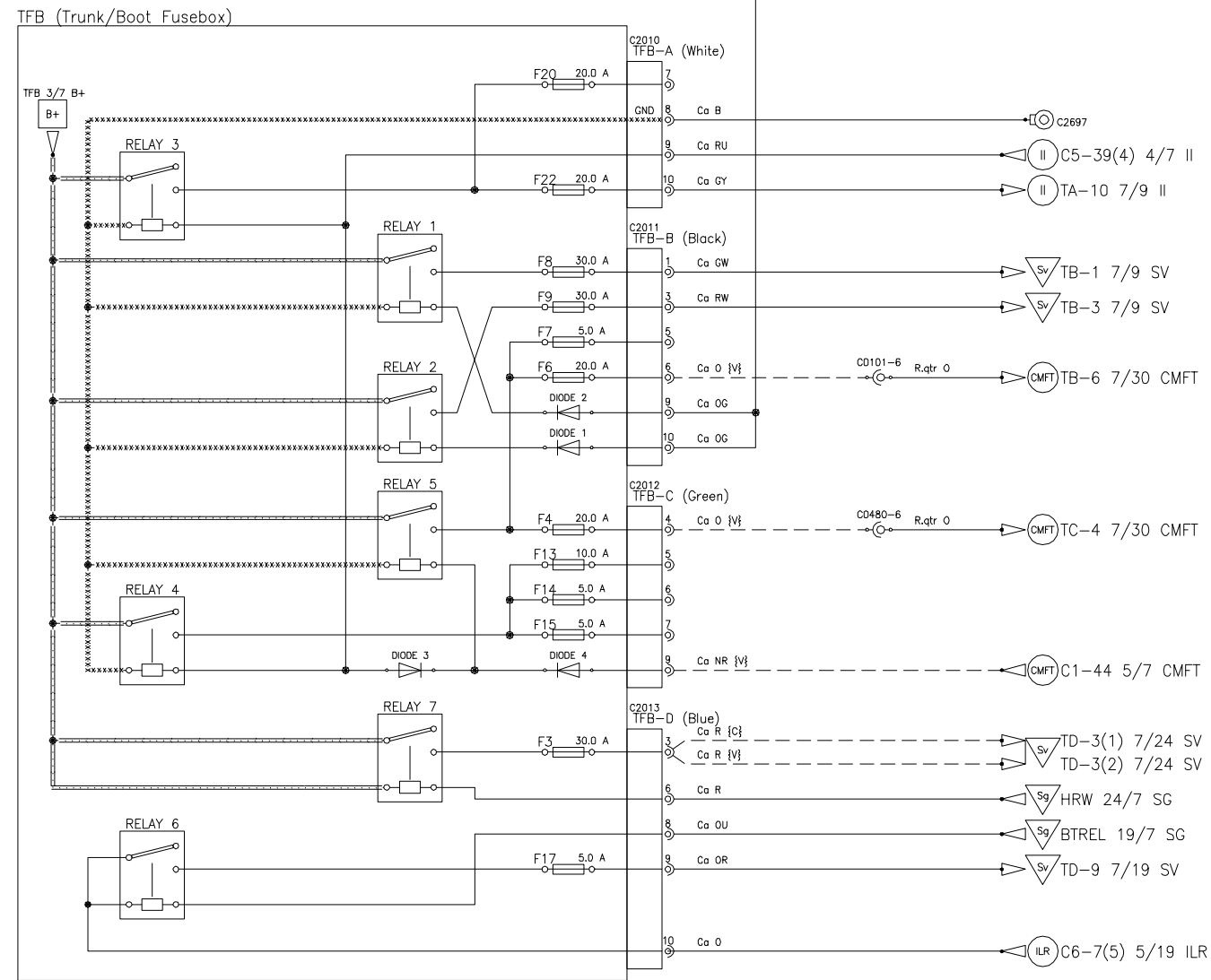
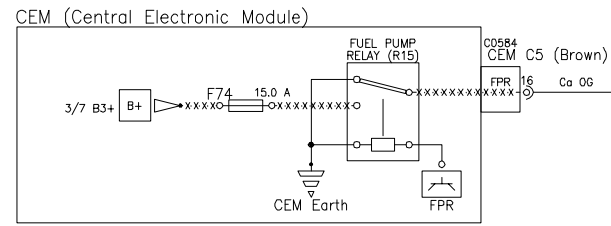

CPSC Code:  
00.06.51

Prog: DB9 / DBS  
Build: 2011MY

TITLE  
SUB-SYSTEM TITLE

## Power Distribution Boot/Trunk Fusebox Relays

AML DRG No.

ILBG43-14T400-AA

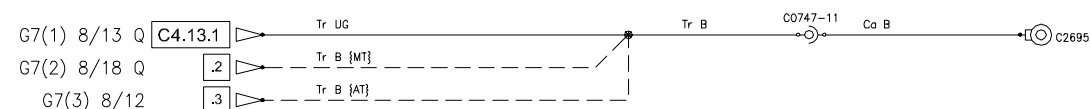
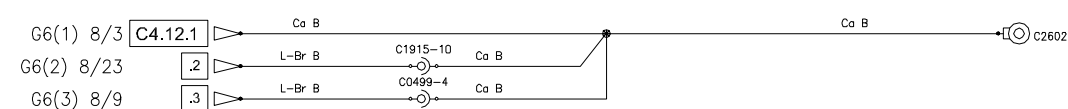
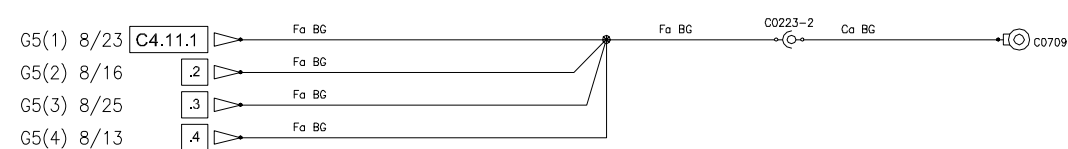
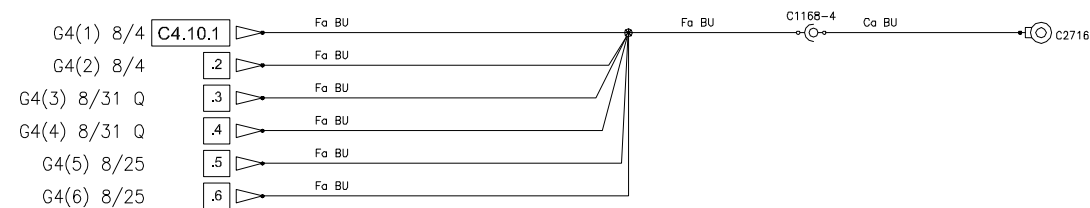
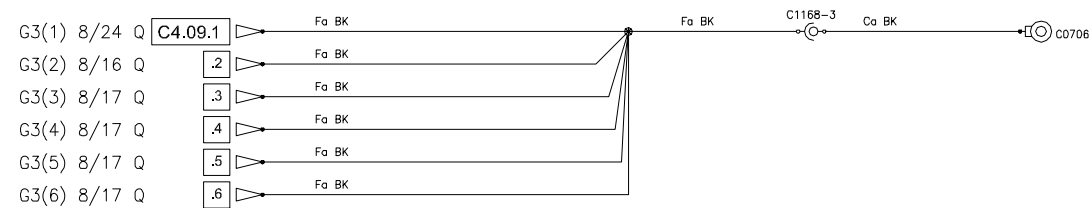
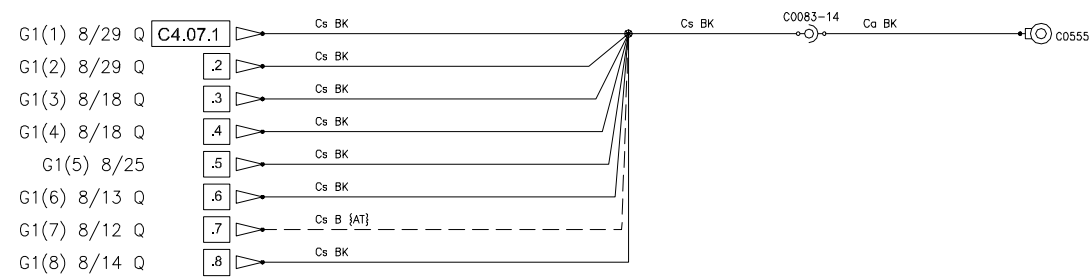

CPSC Code:  
00.06.51

Prog: DB9 / DBS  
Build: 2011MY

TITLE  
SUB-SYSTEM TITLE

# Ground Distribution

-

AML DRG No.

ILBG43-14T400-AA

8

OF 32



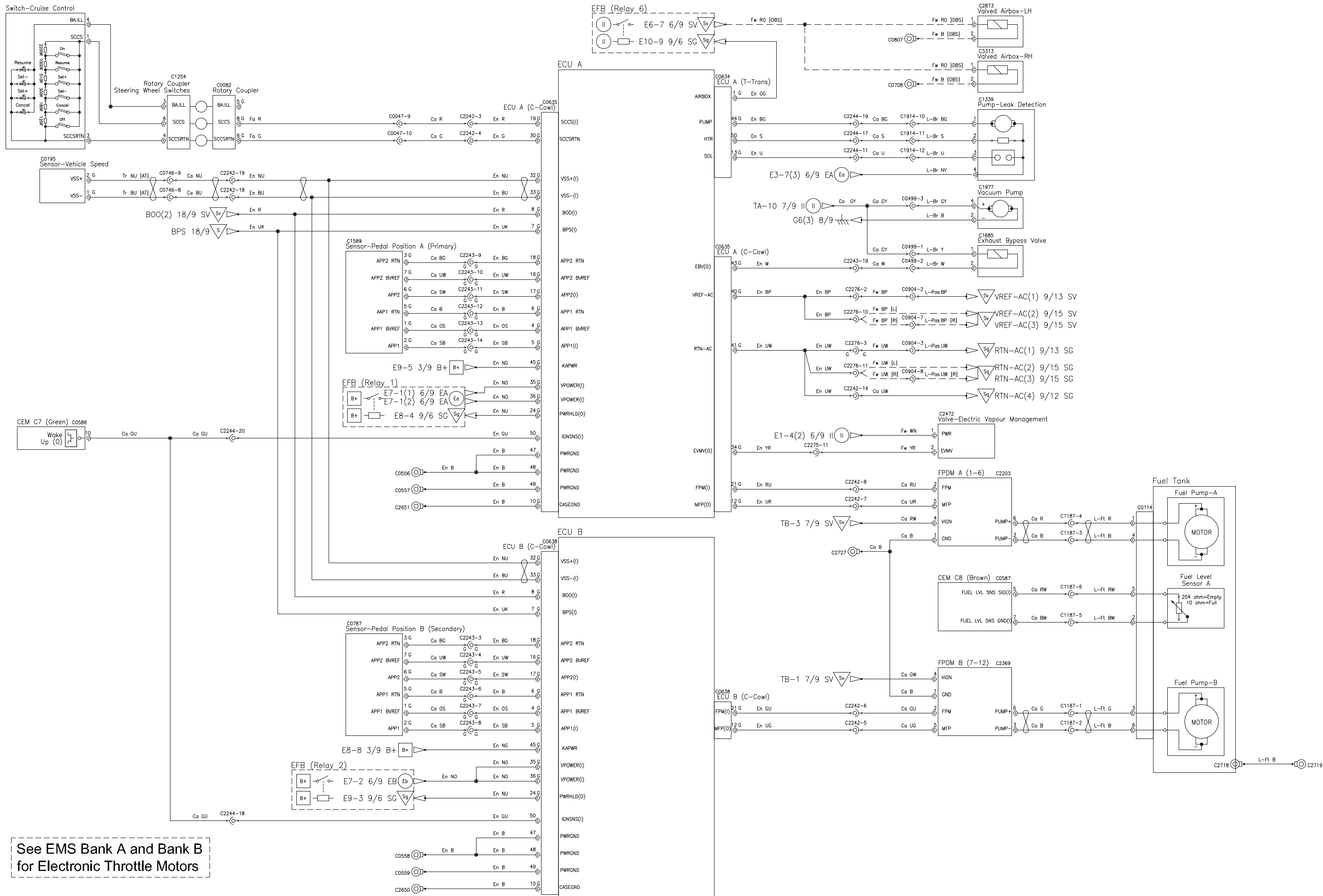

See EMS Bank A and Bank B for Electronic Throttle Motors



CPSC Code: 00.06.51  
 Prog: DB9 / DBS  
 Build: 2011MY

TITLE  
 SUB-SYSTEM TITLE

# Engine Management System

Power, Ground, Fuel, Cruise Control & Exhaust

AML DRG No. ILBG43-14T400-AA

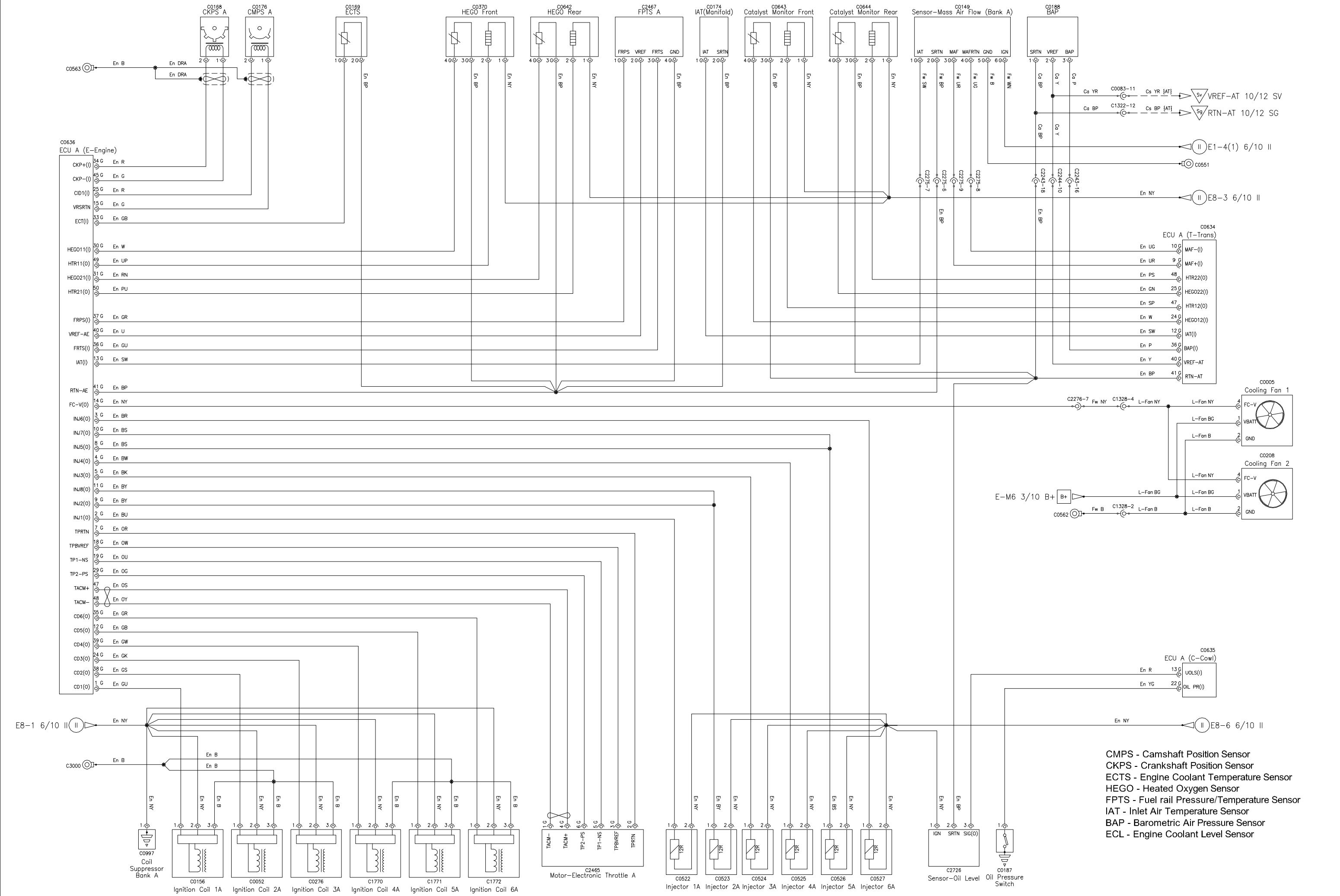

CPSC Code: 00.06.51  
 Prog: DB9 / DBS  
 Build: 2011MY

TITLE: Engine Management System  
 SUB-SYSTEM TITLE: Bank A (RHS) including Cooling Fans

AML DRG No. ILBG43-14T400-AA

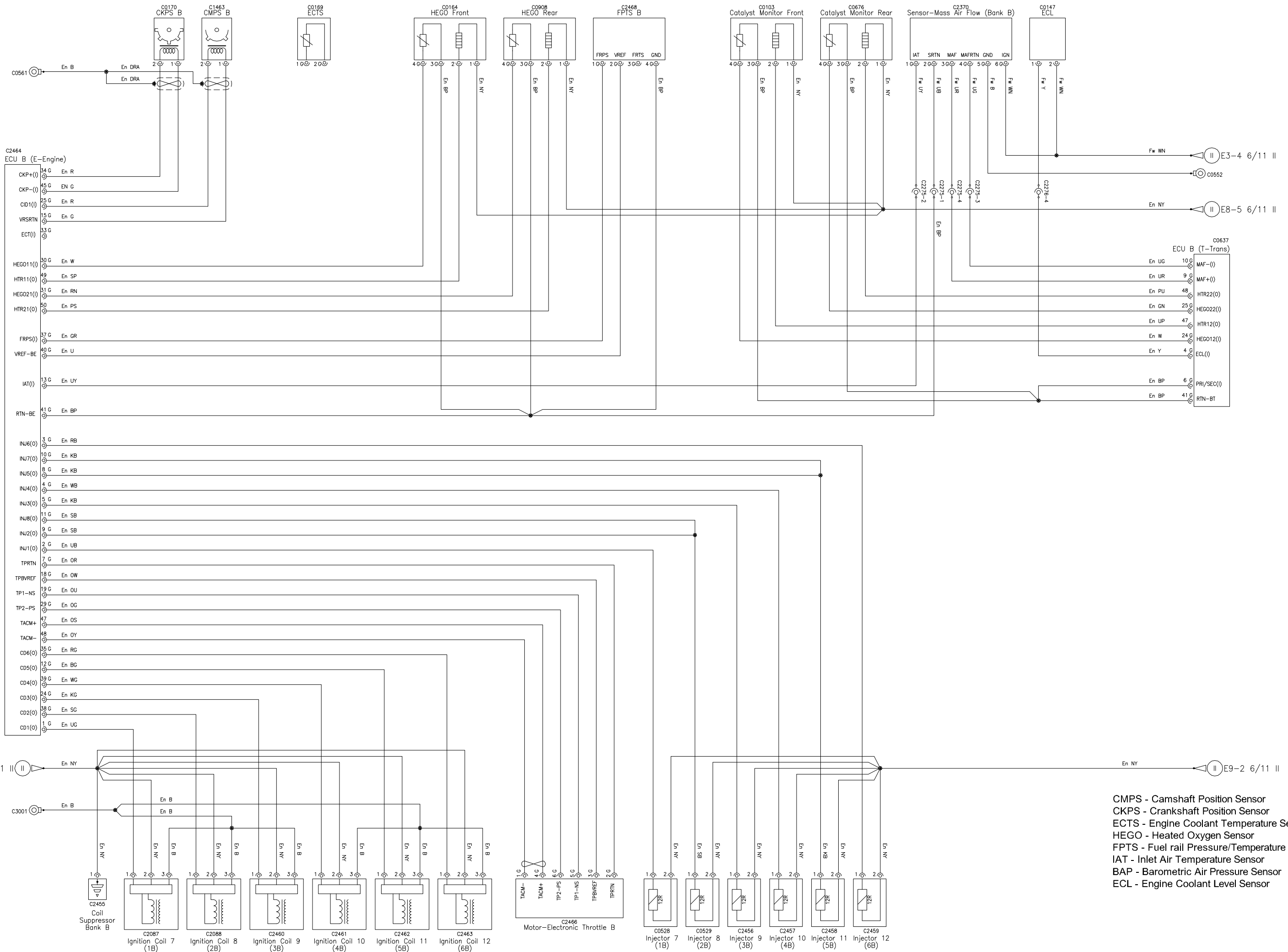

- CMPS - Camshaft Position Sensor
- CKPS - Crankshaft Position Sensor
- ECTS - Engine Coolant Temperature Sensor
- HEGO - Heated Oxygen Sensor
- FPTS - Fuel rail Pressure/Temperature Sensor
- IAT - Inlet Air Temperature Sensor
- BAP - Barometric Air Pressure Sensor
- ECL - Engine Coolant Level Sensor



CPSC Code: 00.06.51  
 Prog: DB9 / DBS  
 Build: 2011MY

TITLE  
 SUB-SYSTEM TITLE

# Engine Management System

## Bank B (LHS)

AML DRG No.  
**ILBG43-14T400-AA**

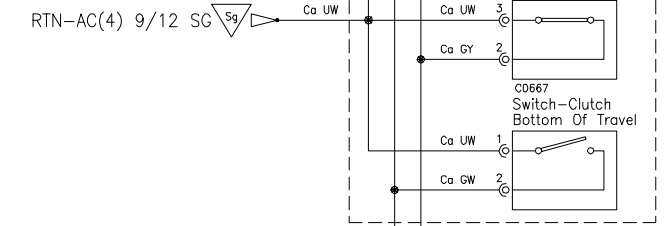
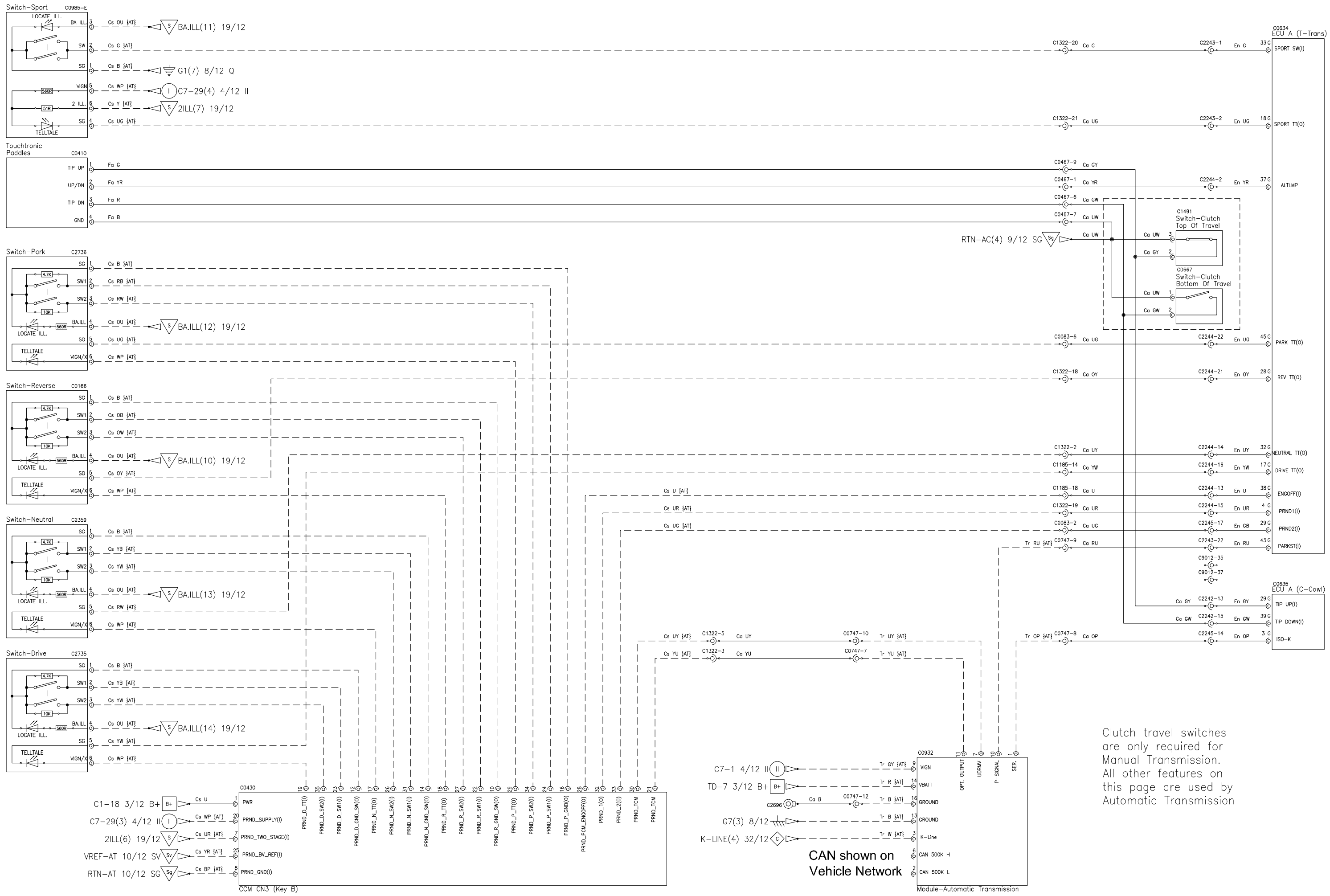

Clutch travel switches are only required for Manual Transmission. All other features on this page are used by Automatic Transmission

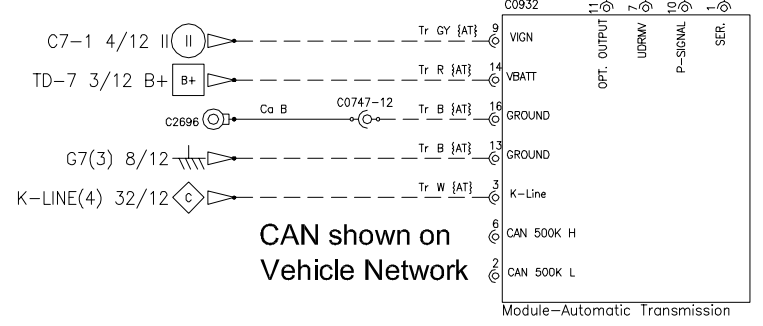

CPSC Code: 00.06.51  
 Prog: DB9 / DBS  
 Build: 2011MY

TITLE  
 SUB-SYSTEM TITLE

# Transmission

## Automatic Systems and Manual Clutch Switches

AML DRG No. ILBG43-14T400-AA

# Braking

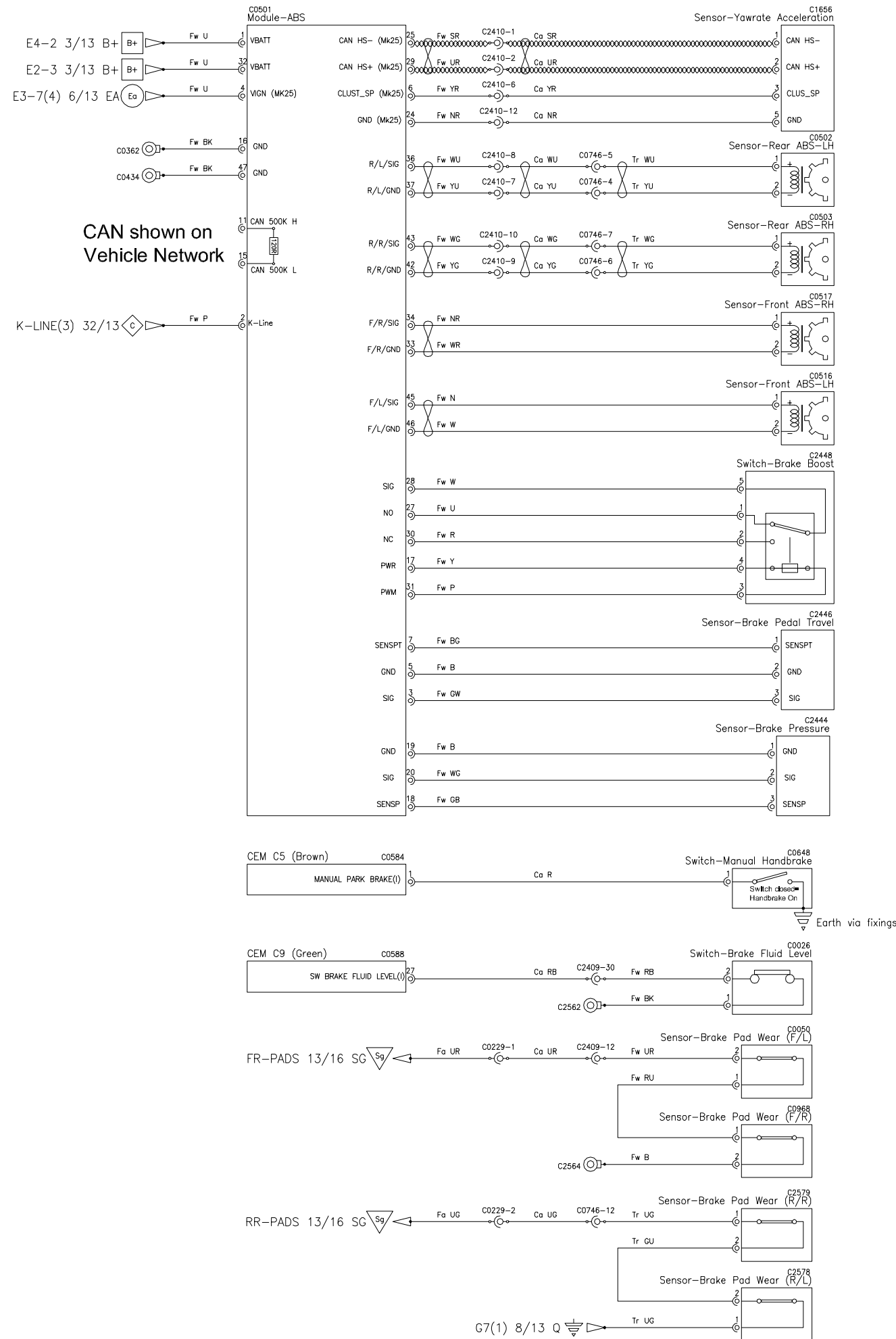

# Steering

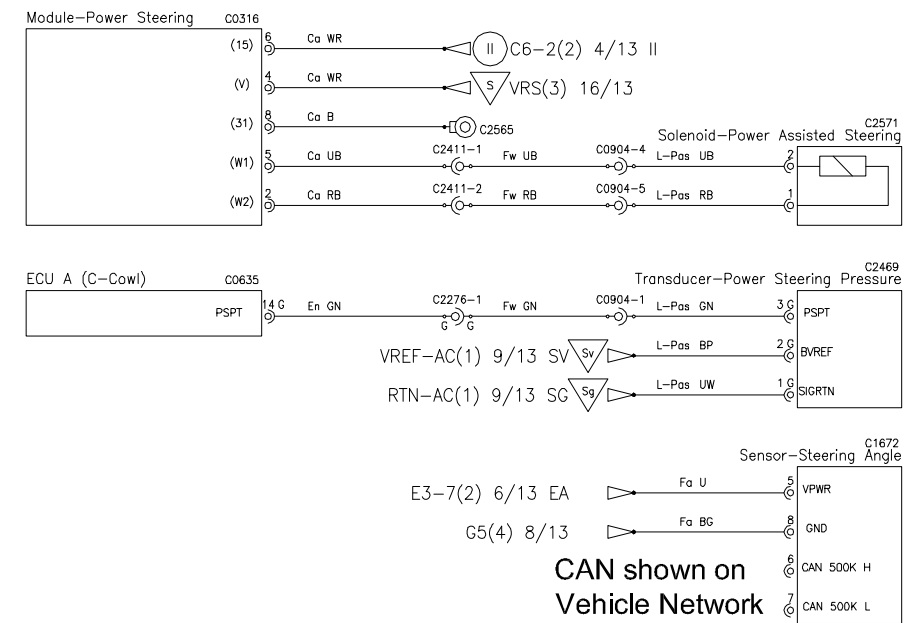

# Stability Control

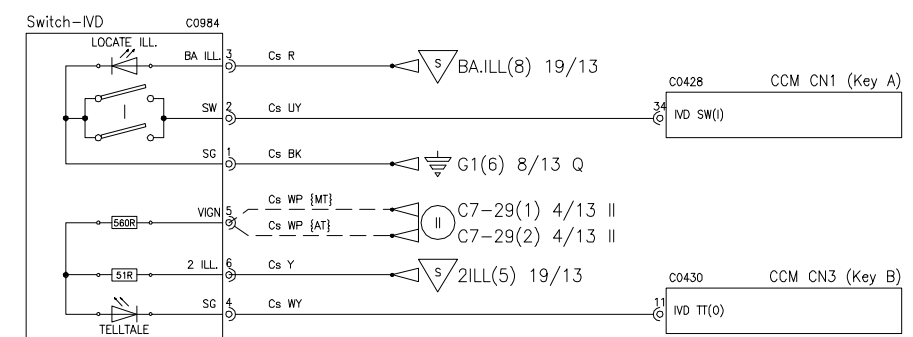

CPSC Code: 00.06.51  
 Prog: DB9 / DBS  
 Build: 2011MY  
 TITLE: SUB-SYSTEM TITLE

## Chassis

Braking, Steering, Stability Control

AML DRG No. ILBG43-14T400-AA

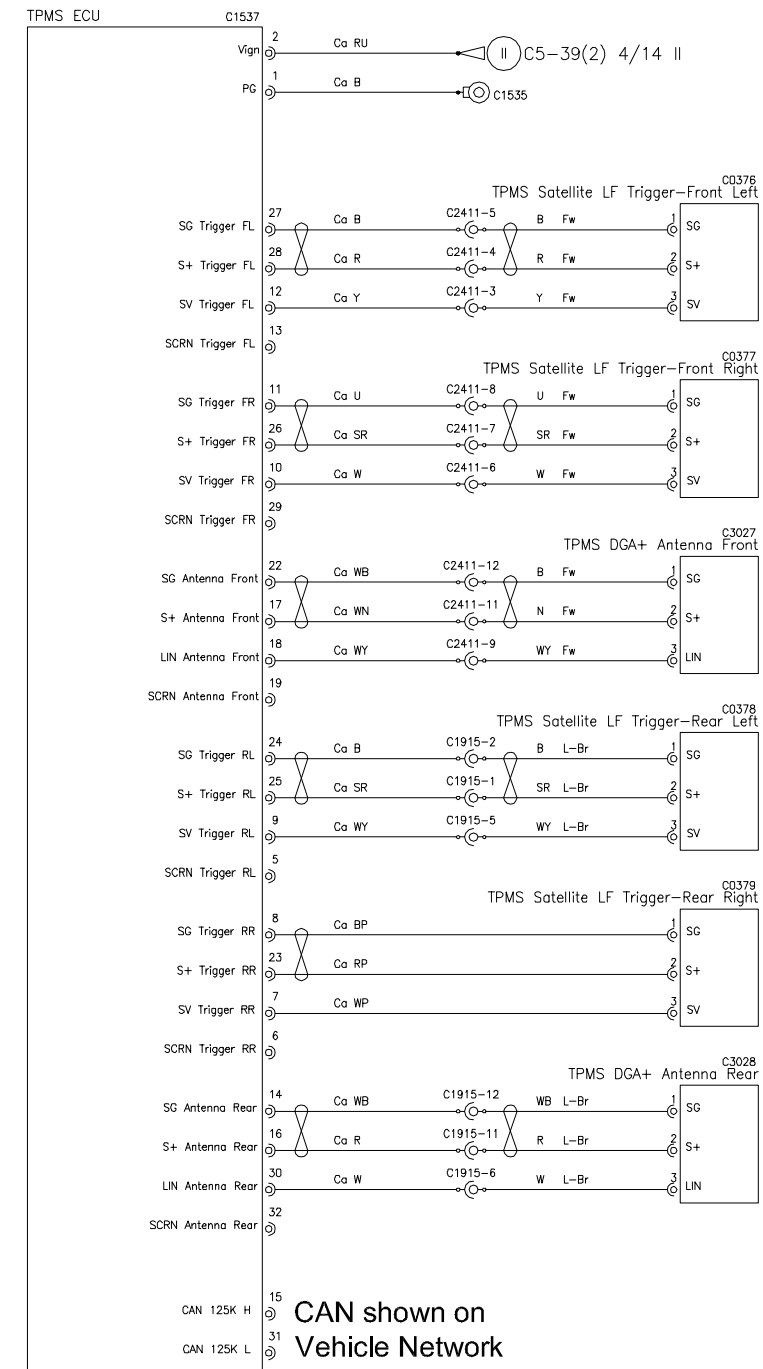
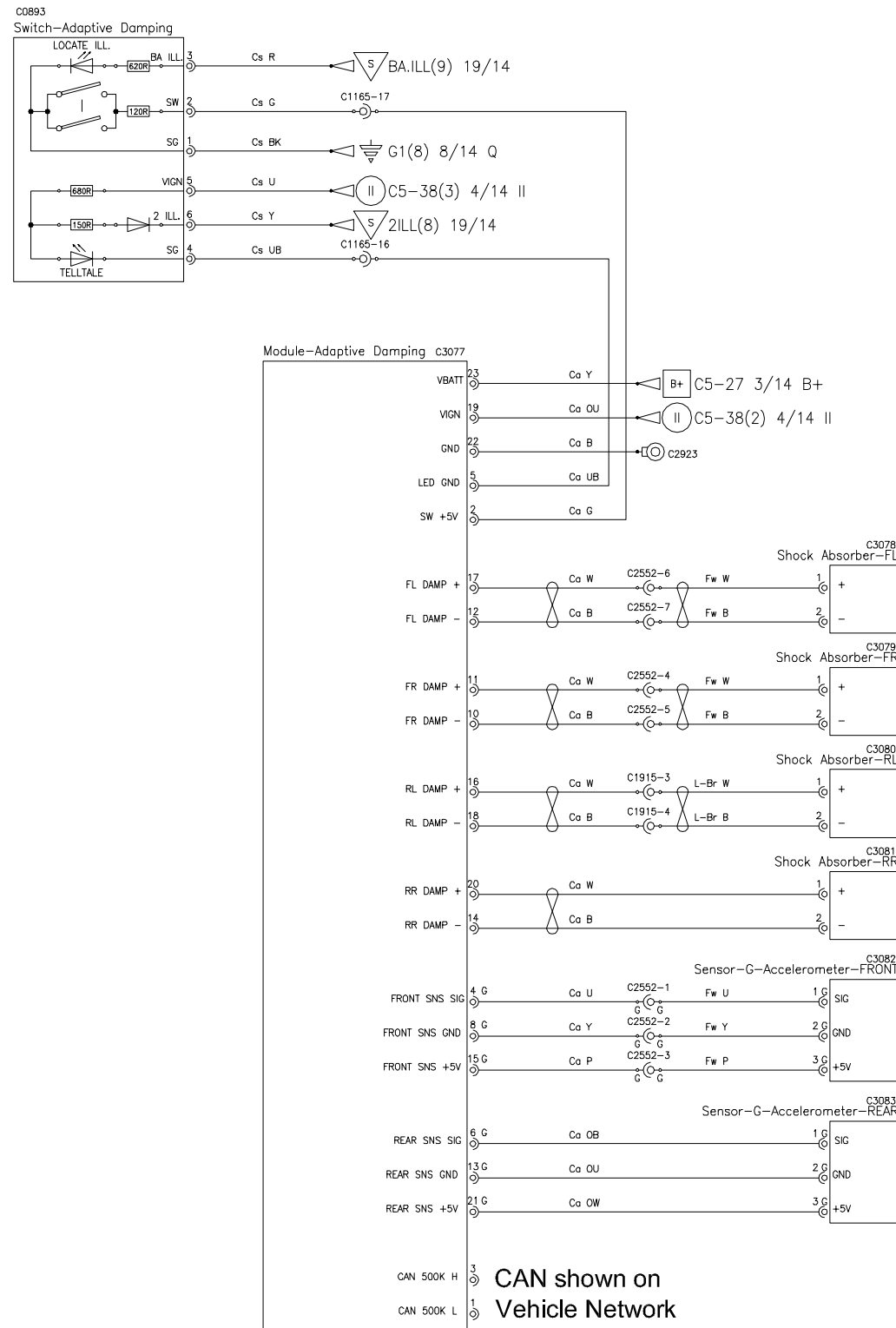

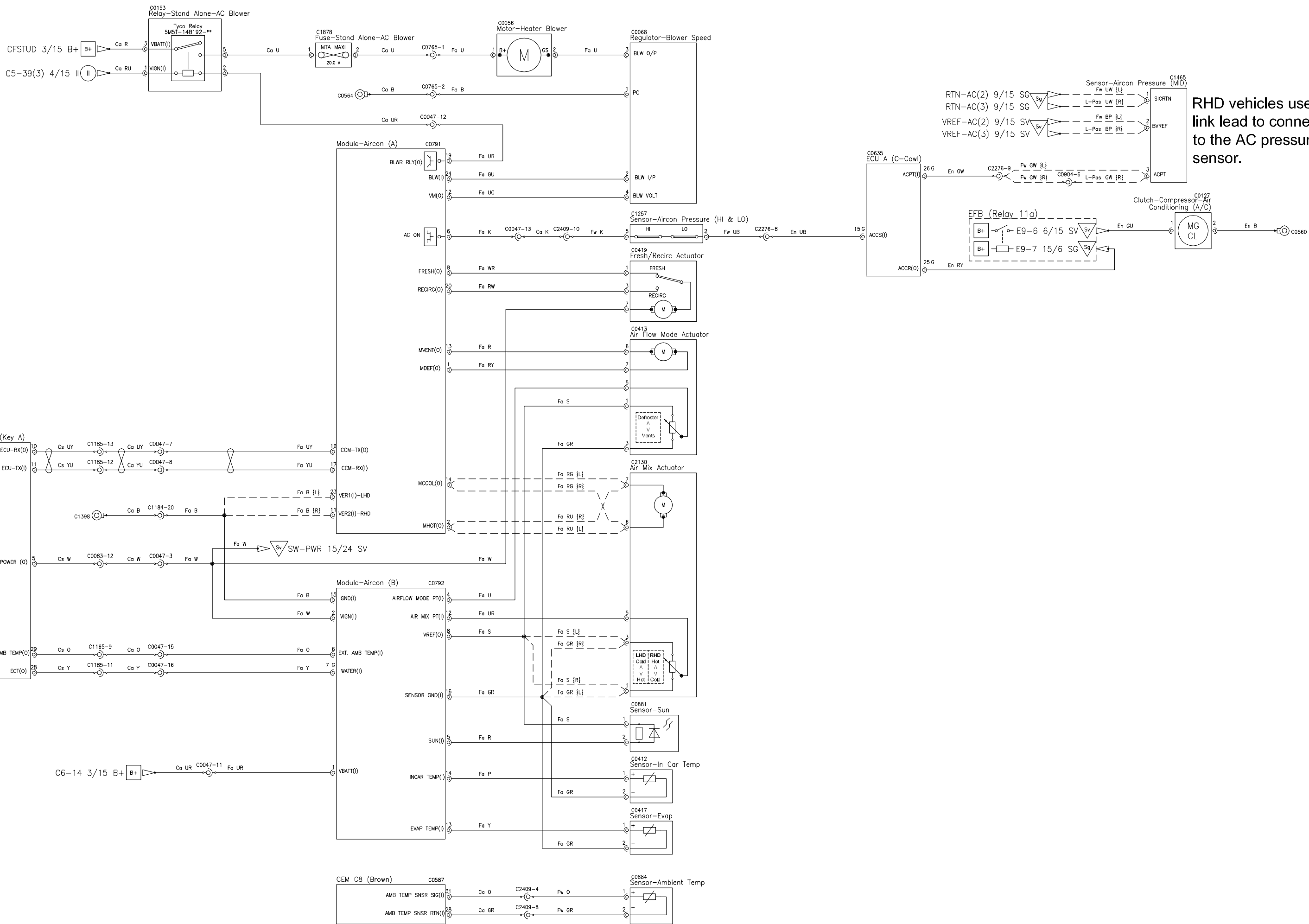

RHD vehicles use a link lead to connect to the AC pressure sensor.



CPSC Code: 00.06.51  
 Prog: DB9 / DBS  
 Build: 2011MY

TITLE  
 SUB-SYSTEM TITLE

# Climate Control

AML DRG No.  
 ILBG43-14T400-AA

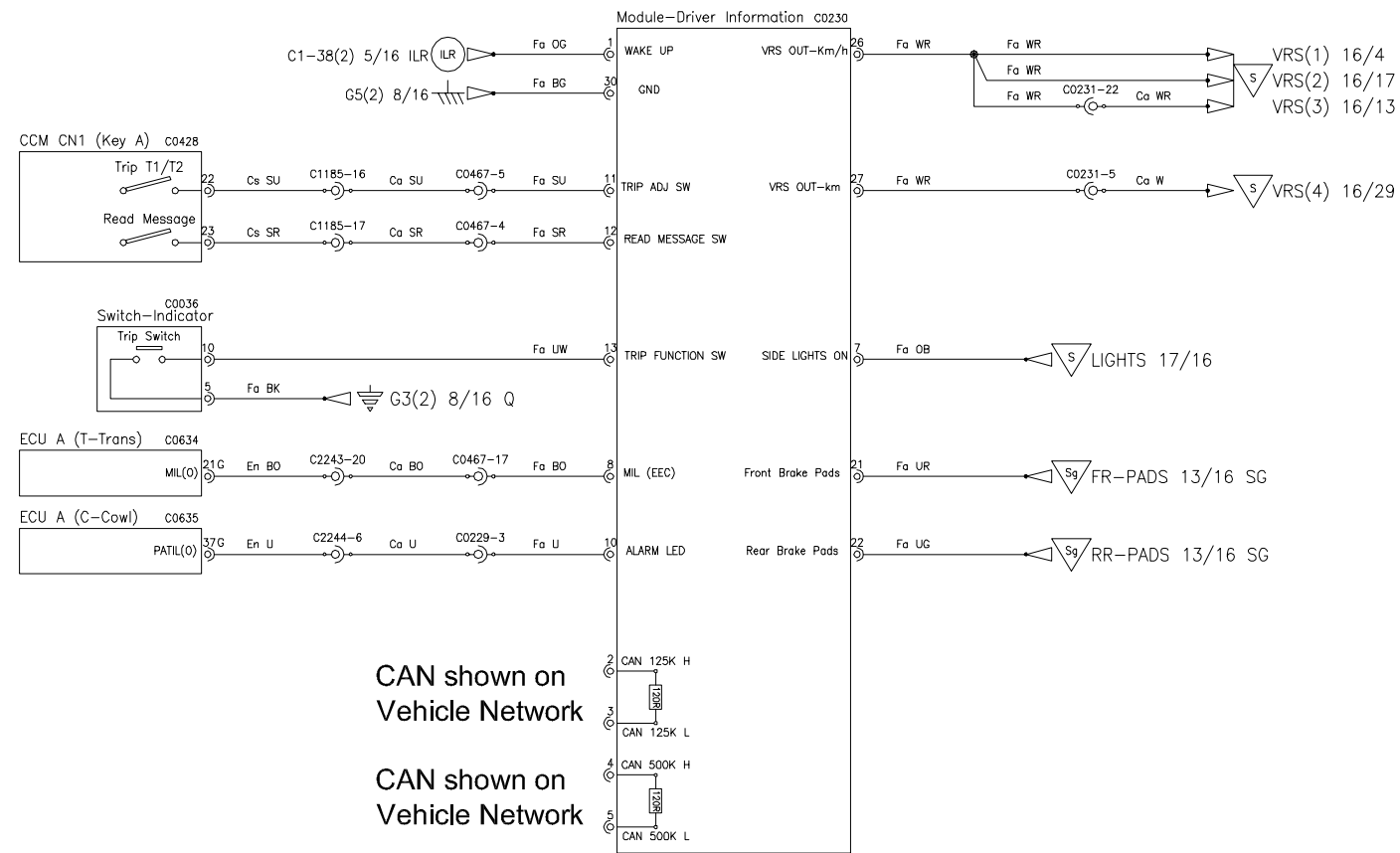

CPSC Code:  
00.06.51

Prog: DB9 / DBS  
Build: 2011MY

TITLE  
SUB-SYSTEM TITLE

# Instrument Pack

-

AML DRG No.

ILBG43-14T400-AA

16

OF 32



CEM (Central Electronic Module)

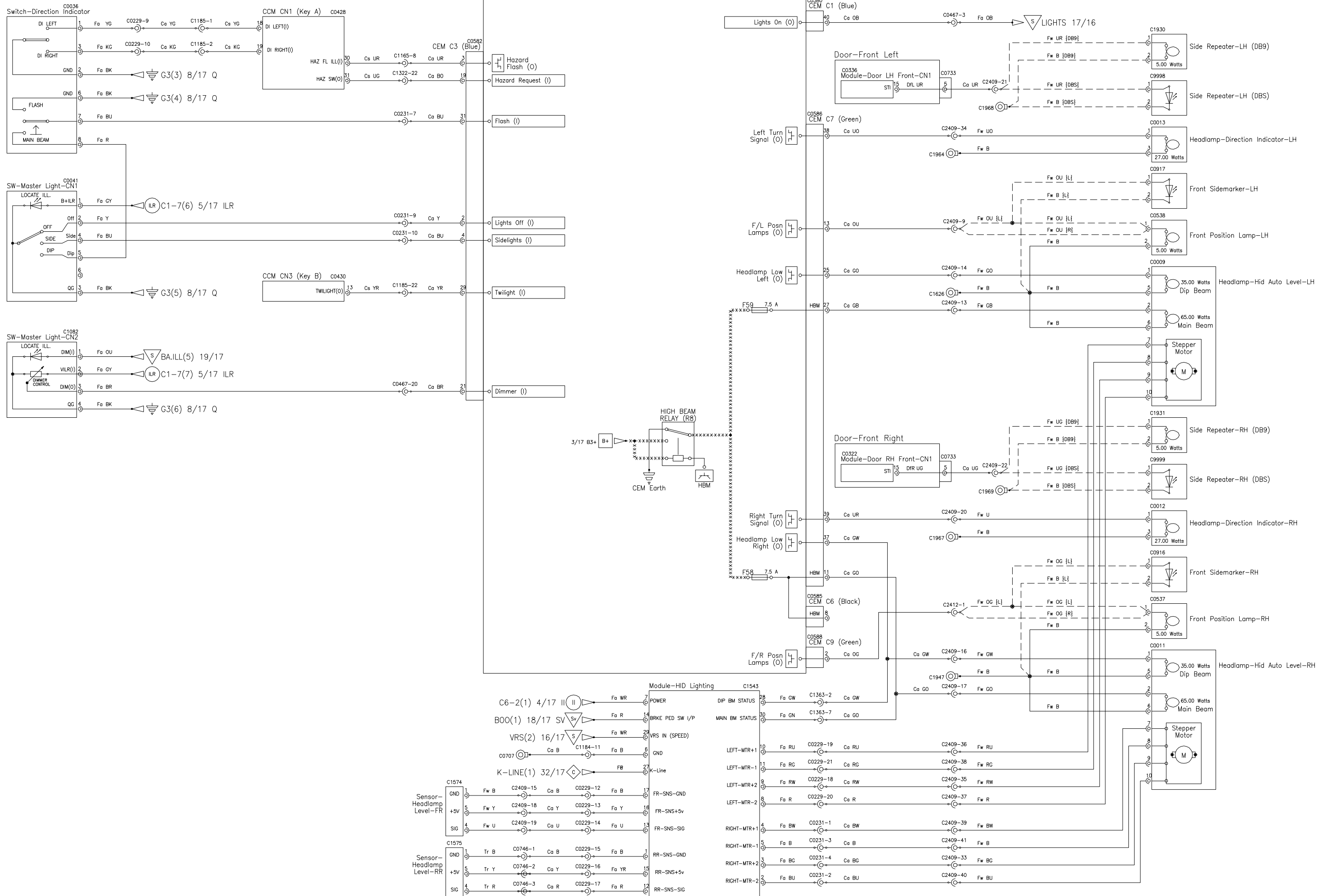

CPSC Code: 00.06.51  
 Prog: DB9 / DBS  
 Build: 2011MY

TITLE: Exterior Lighting Front  
 SUB-SYSTEM TITLE

Exterior Lighting Front

AML DRG No. ILBG43-14T400-AA

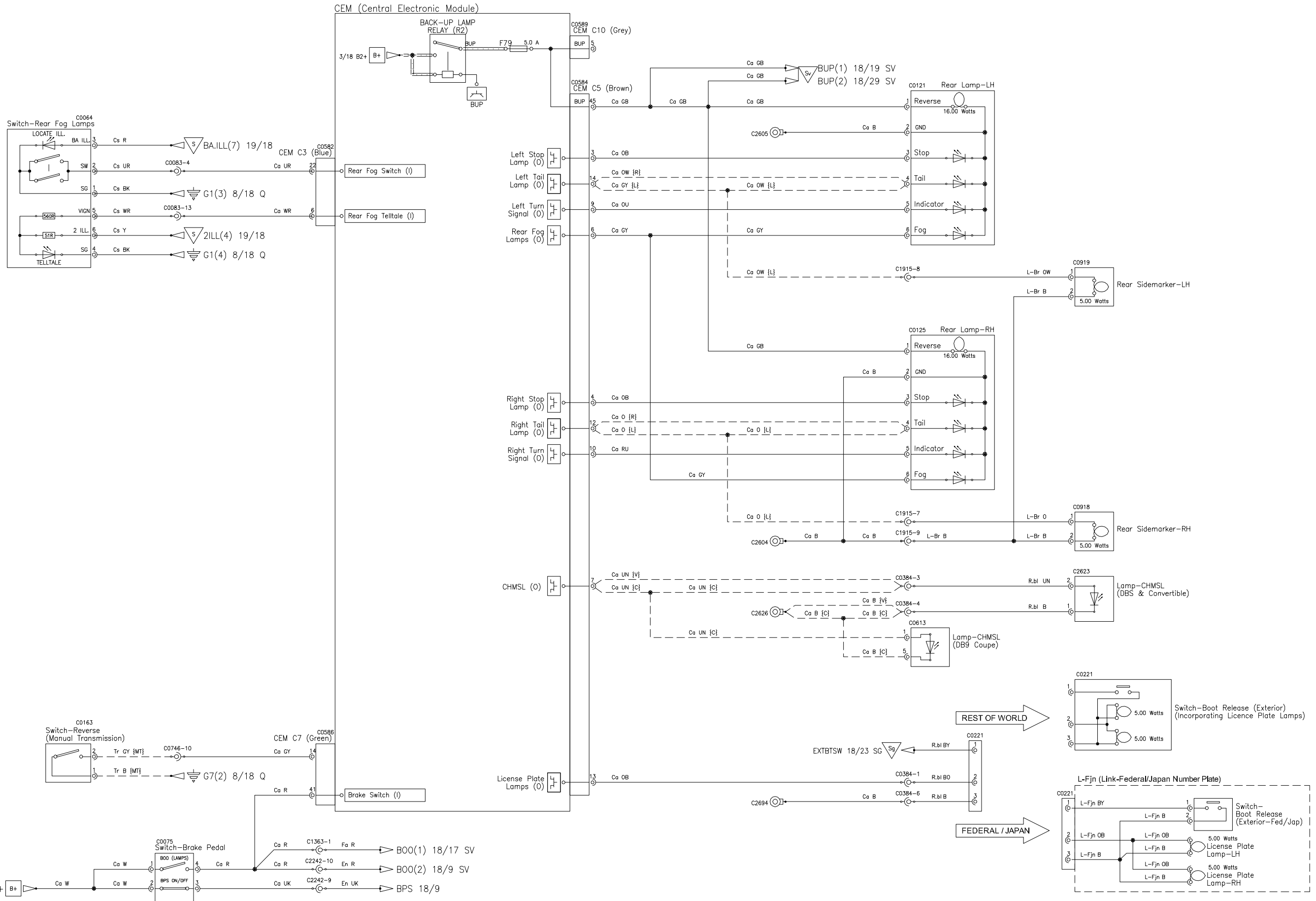

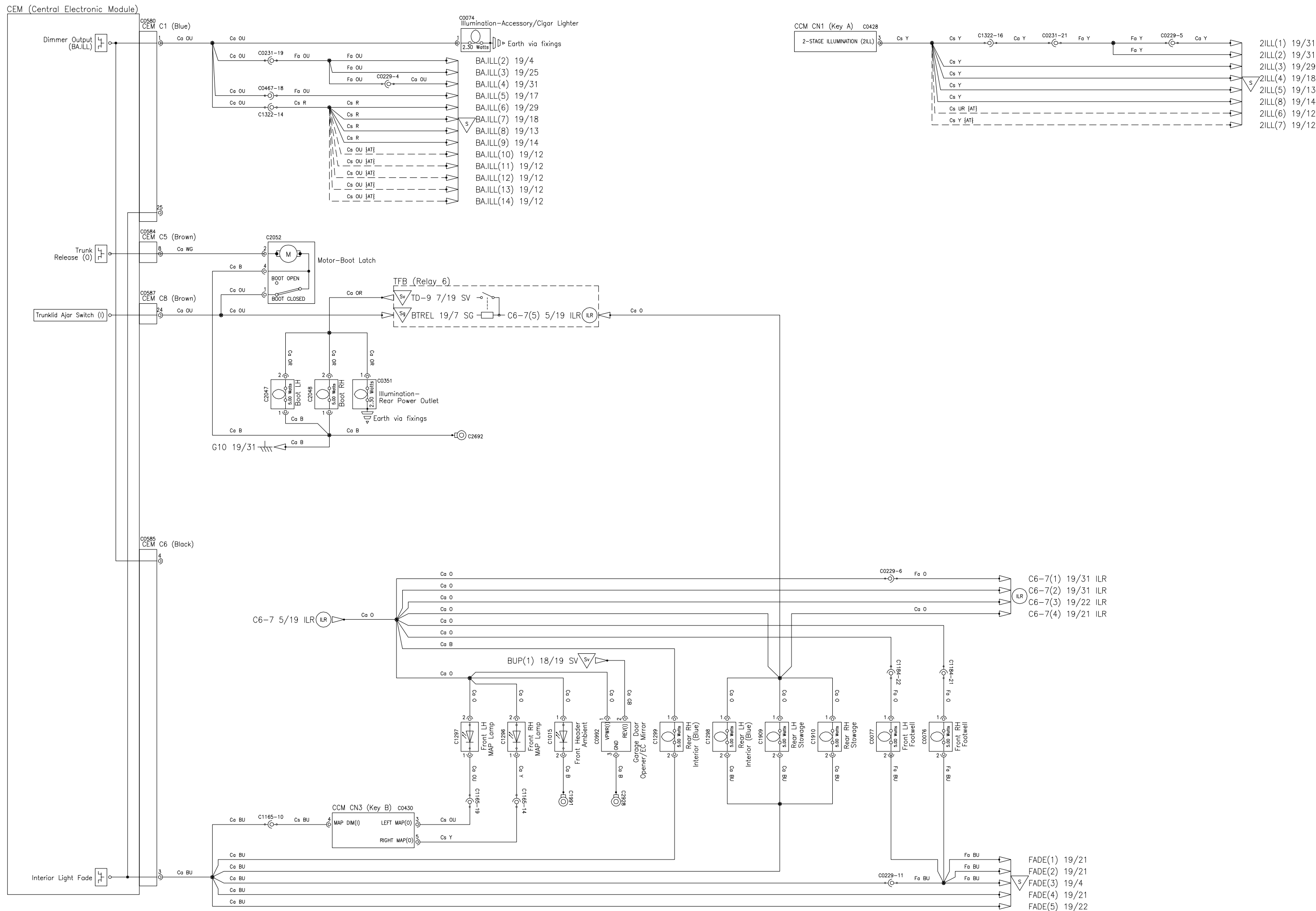

CPSC Code: 00.06.51  
 Prog: DB9 / DBS  
 Build: 2011MY  
 TITLE: Interior Lighting (BA.ILL, FADE, 2ILL)  
 SUB-SYSTEM TITLE: Including Boot Latch and GDO

**Interior Lighting (BA.ILL, FADE, 2ILL)**  
 Including Boot Latch and GDO

AML DRG No. ILBG43-14T400-AA

Door-Front Left

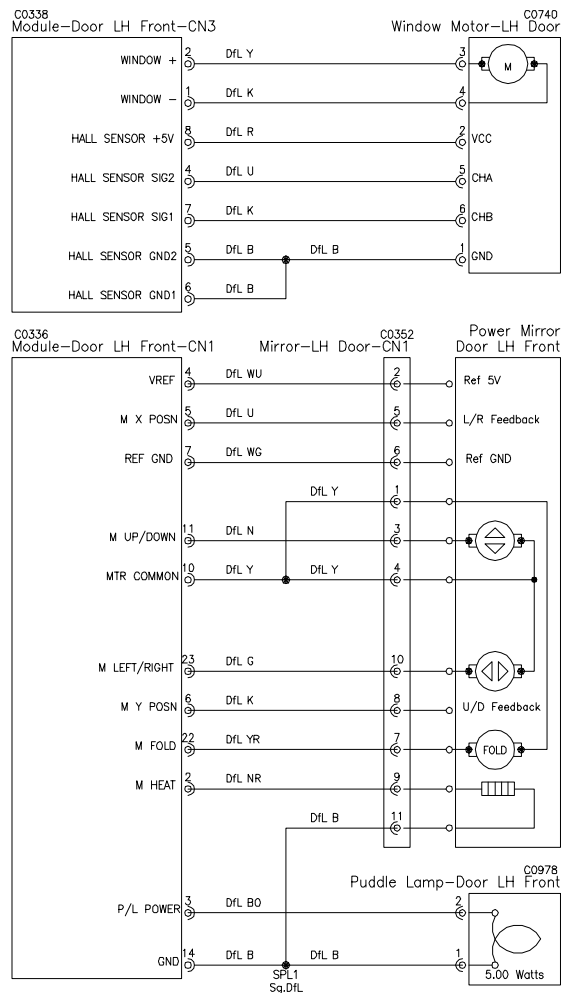

Door-Front Left LHD (Driver Door Switchpack)

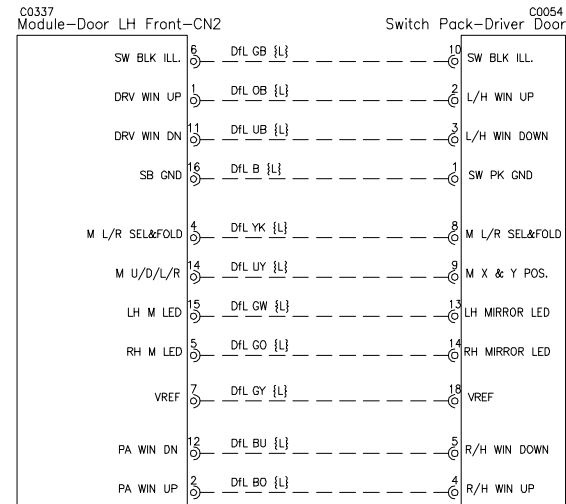

Door-Front Left RHD (Passenger Door Switchpack)

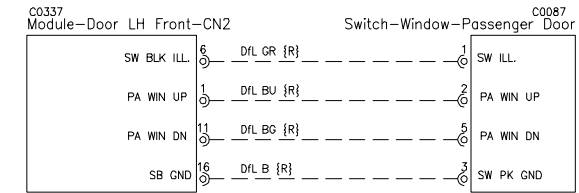

Door-Front Right

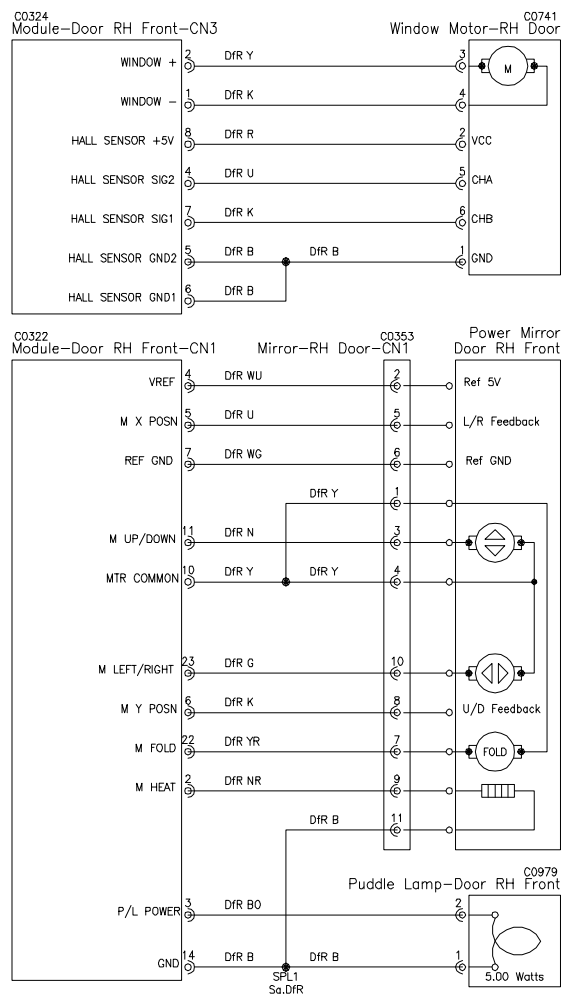

Door-Front Right LHD (Passenger Door Switchpack)

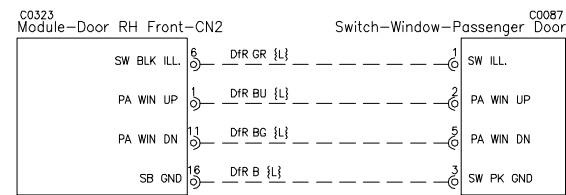

Door-Front Right RHD (Driver Door Switchpack)

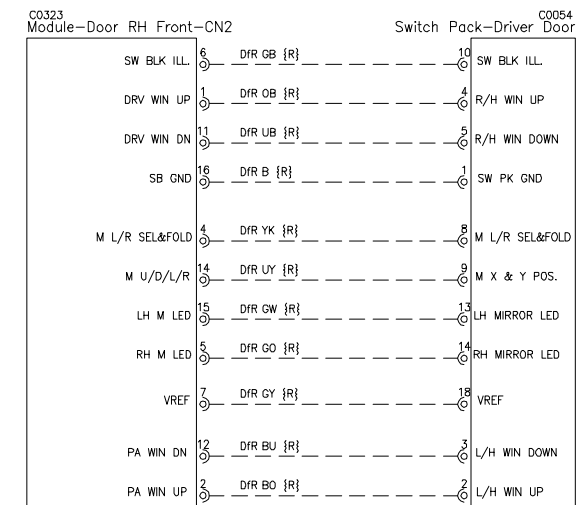

CPSC Code: 00.06.51

Prog: DB9 / DBS  
Build: 2011MY

TITLE  
SUB-SYSTEM TITLE

Door Mirrors and Windows  
Driver & Passenger

AML DRG No.

ILBG43-14T400-AA

# Sports Seat

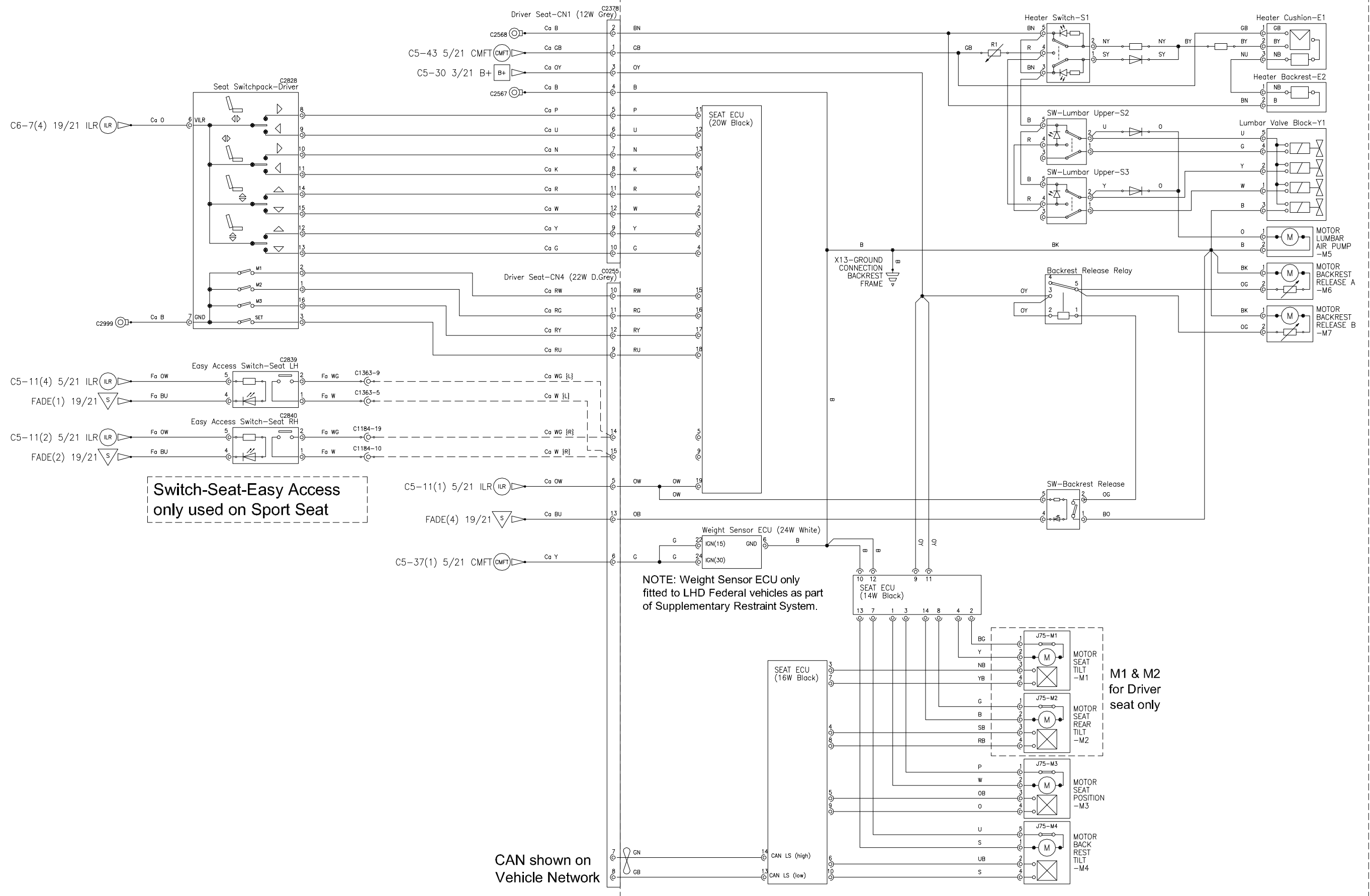

CPSC Code: 00.06.51  
 Prog: DB9 / DBS  
 Build: 2011MY

TITLE  
 SUB-SYSTEM TITLE

## Seat - Driver (shown with Sport Seat harness)

AML DRG No.  
**ILBG43-14T400-AA**

Lightweight Seat

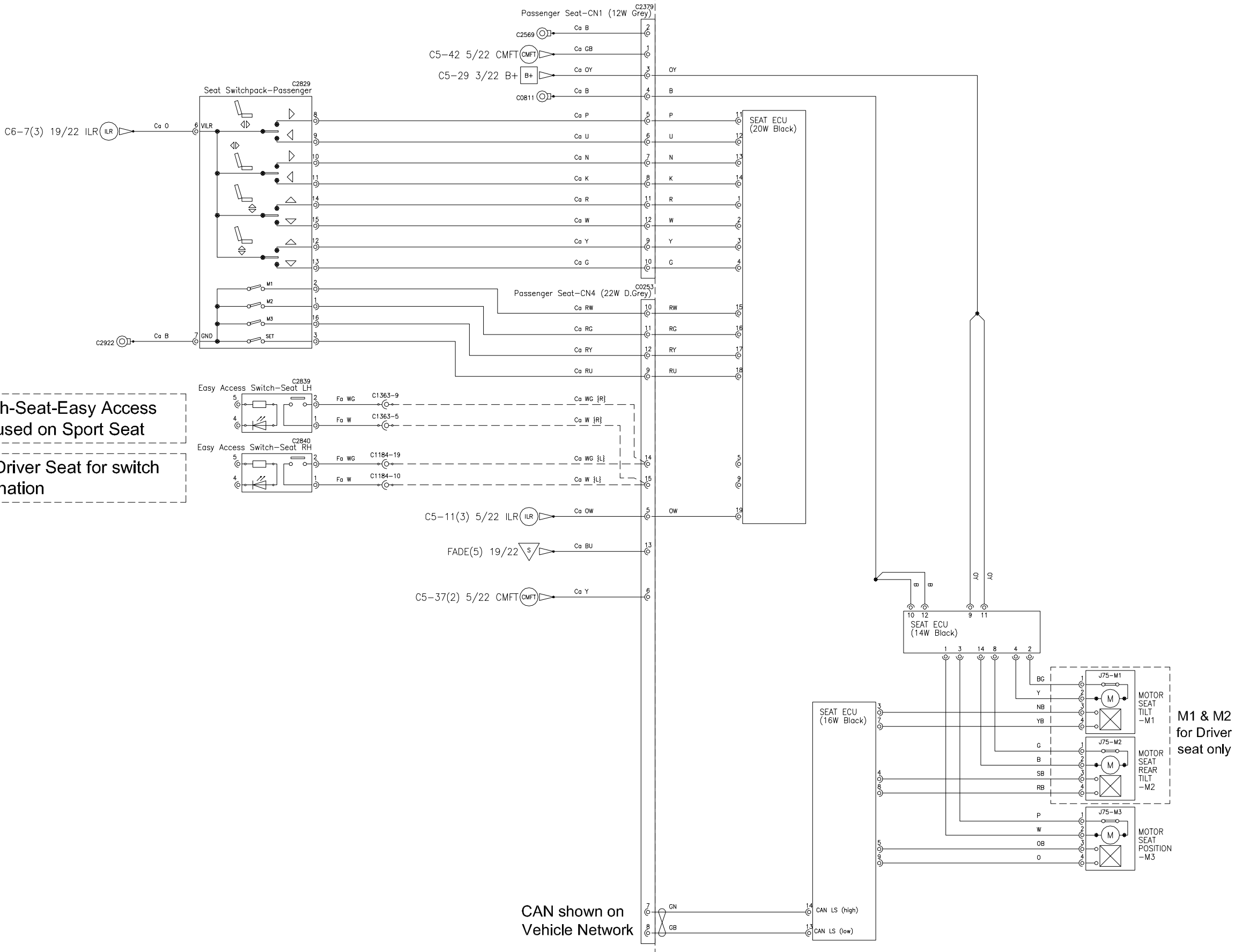

Switch-Seat-Easy Access only used on Sport Seat

See Driver Seat for switch illumination

M1 & M2 for Driver seat only

CAN shown on Vehicle Network



CPSC Code: 00.06.51  
 Prog: DB9 / DBS  
 Build: 2011MY

TITLE  
 SUB-SYSTEM TITLE

Seat - Passenger  
 (shown with Lightweight Seat harness)

AML DRG No.  
 ILBG43-14T400-AA

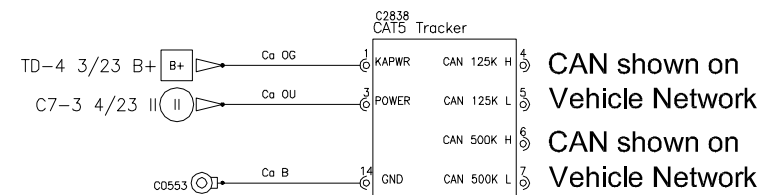

CAN shown on Vehicle Network  
CAN shown on Vehicle Network

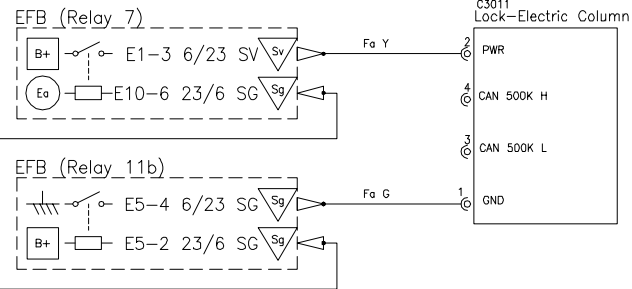
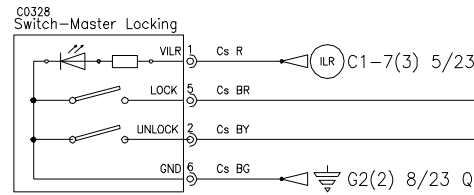

CAN shown on Vehicle Network

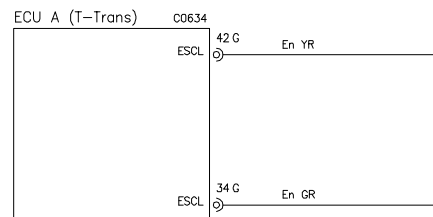

CEM (Central Electronic Module)

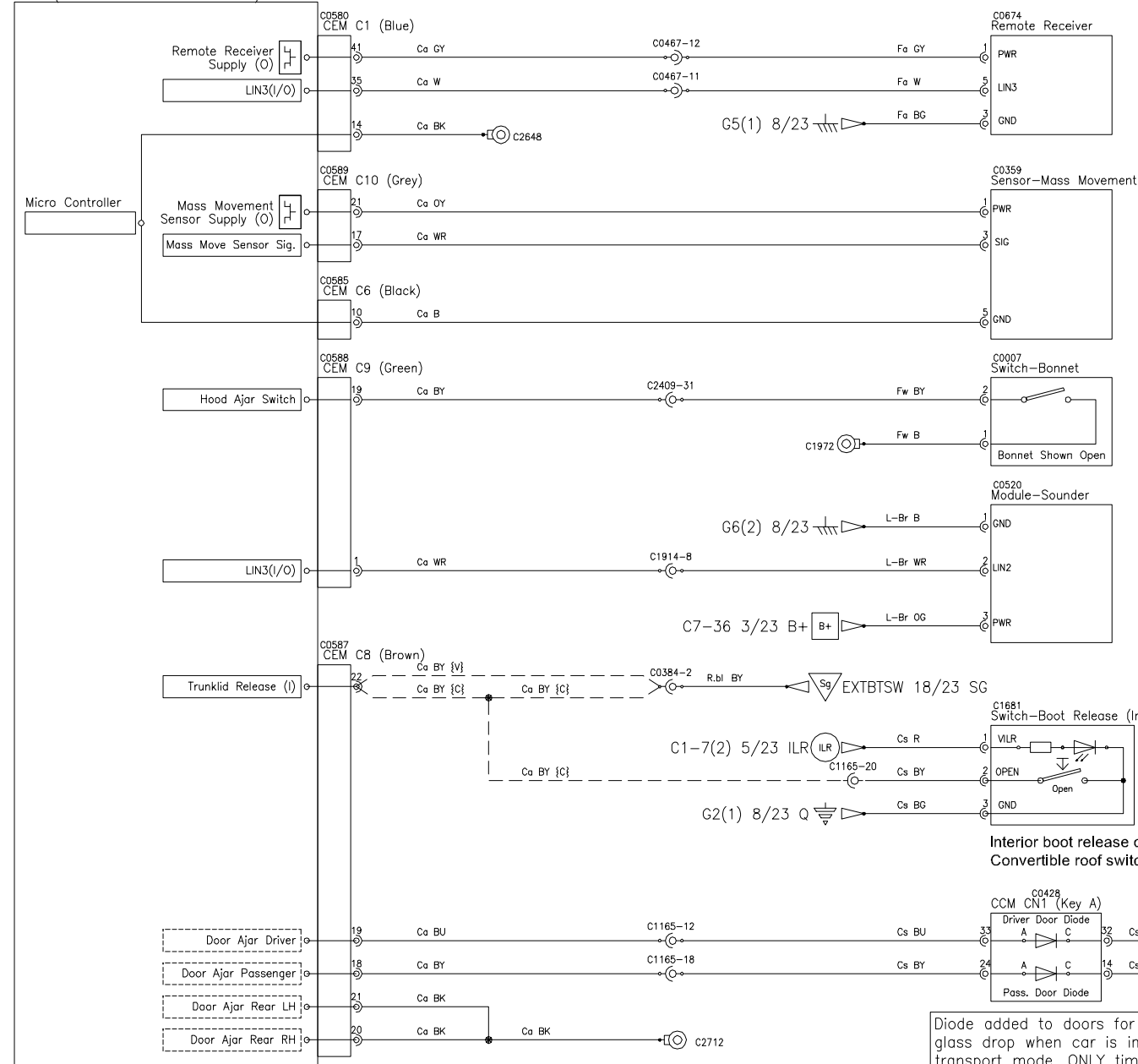

Interior boot release only fitted to Coupe.  
Convertible roof switch fitted to Volante.

Diode added to doors for glass drop when car is in transport mode. ONLY time that diode is in operation.

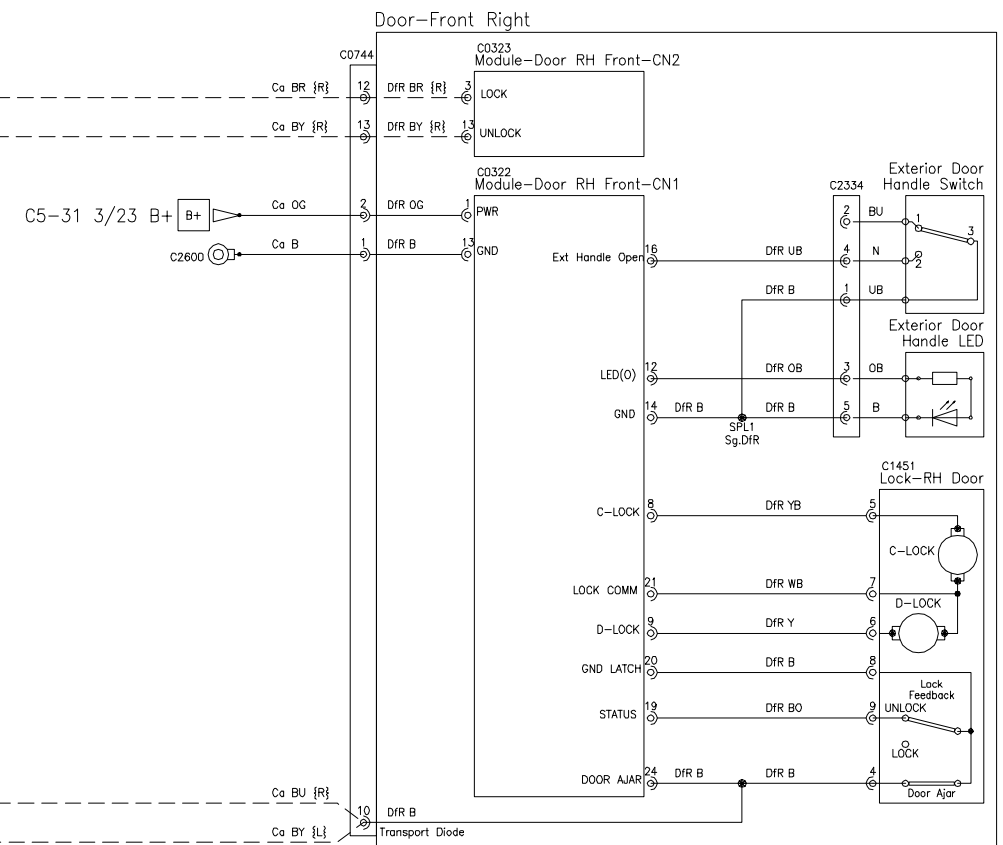
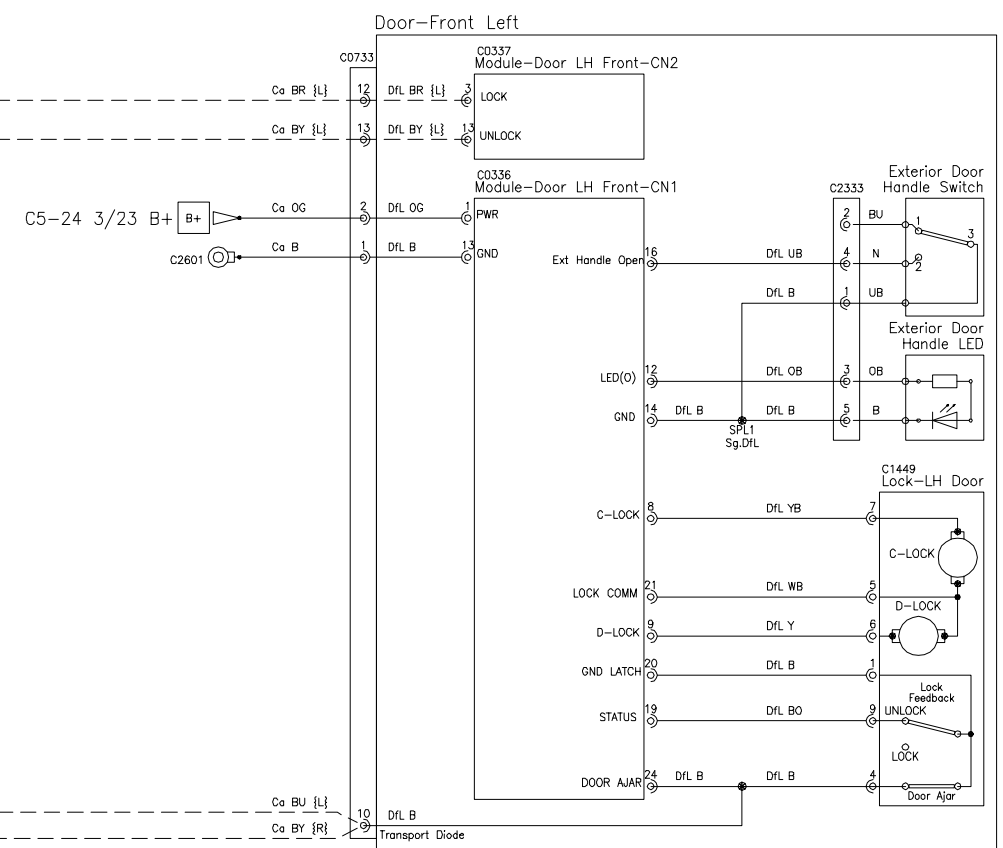

WINDSCREEN WIPERS WILL NOT OPERATE WITH THE BONNET OPEN.

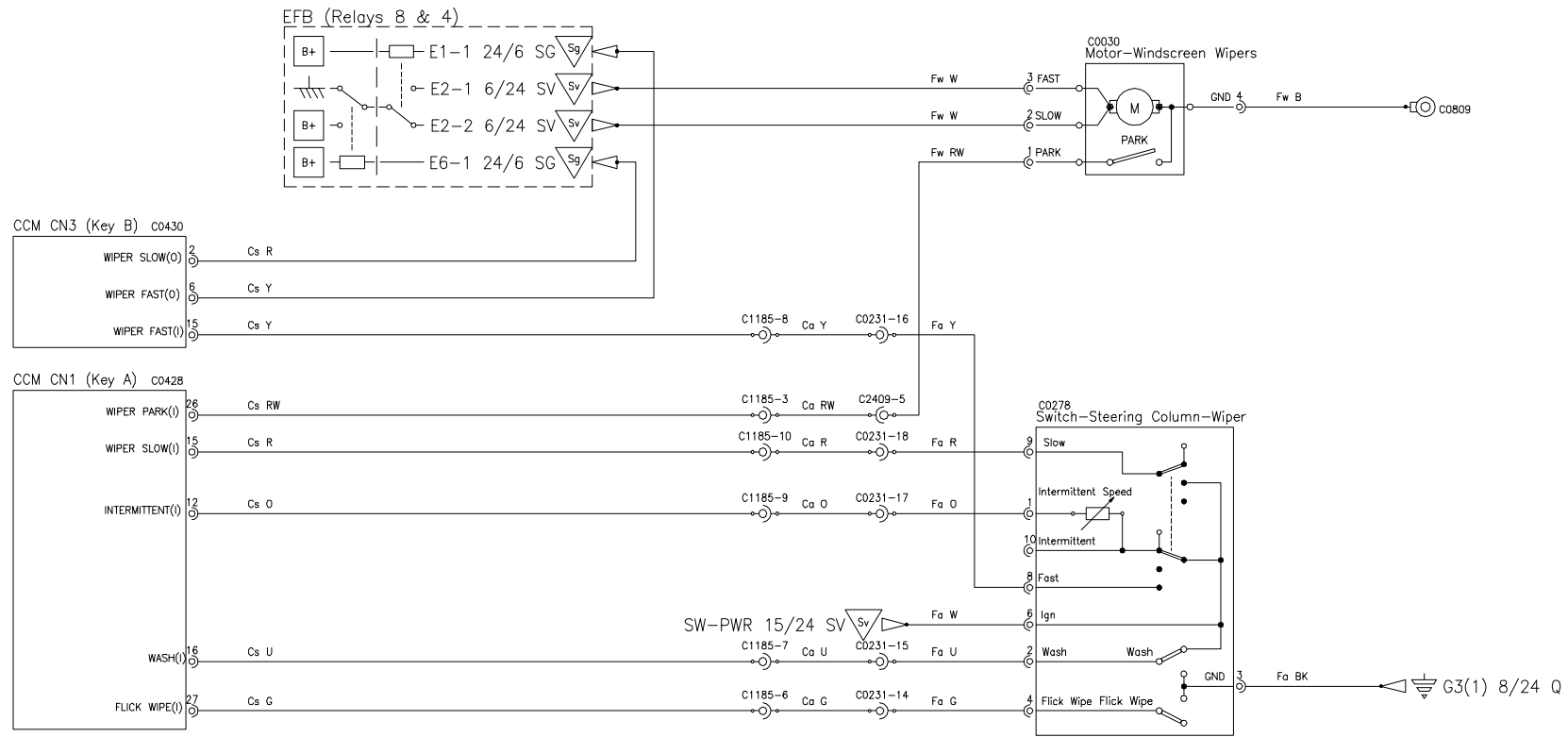

CEM (Central Electronic Module)

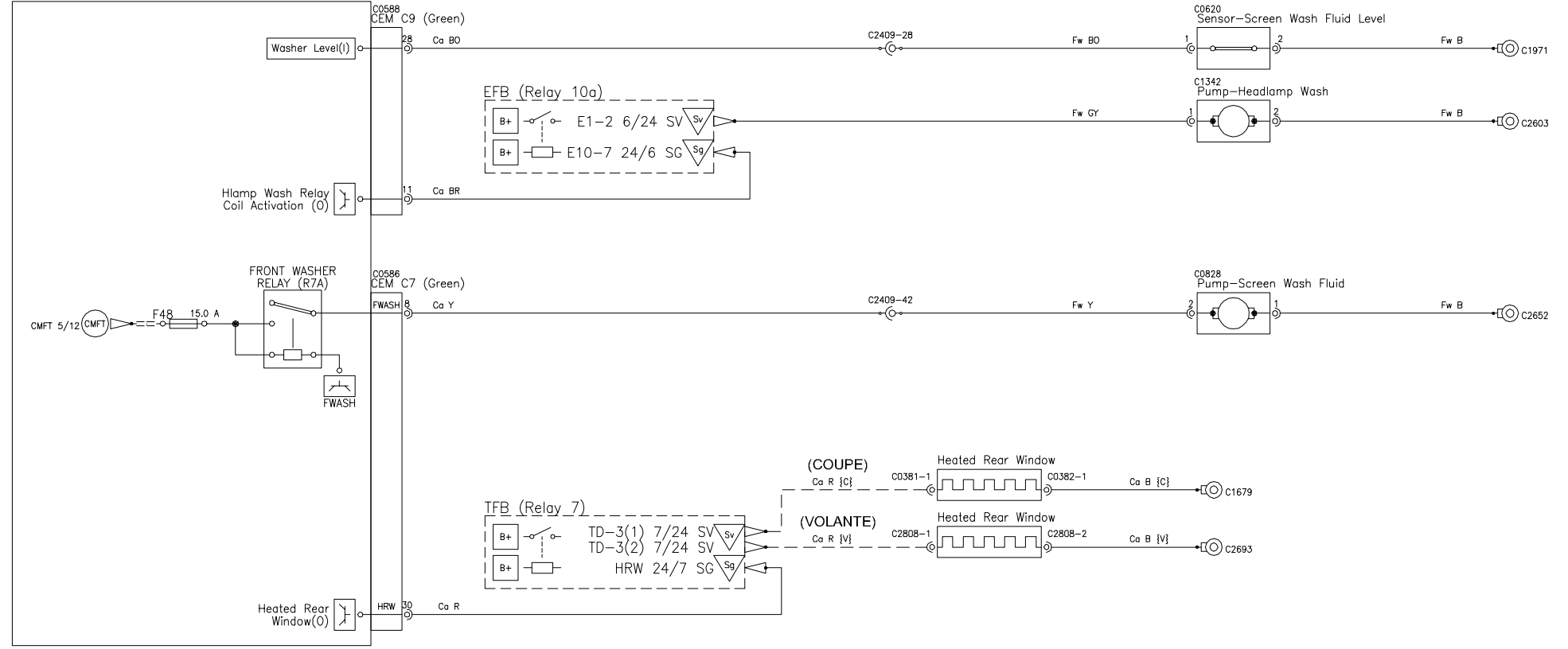

CPSC Code: 00.06.51  
 Prog: DB9 / DBS  
 Build: 2011MY

TITLE  
 SUB-SYSTEM TITLE

Wash / Wipe System  
 Including Heated Rear Screen

AML DRG No.  
 ILBG43-14T400-AA



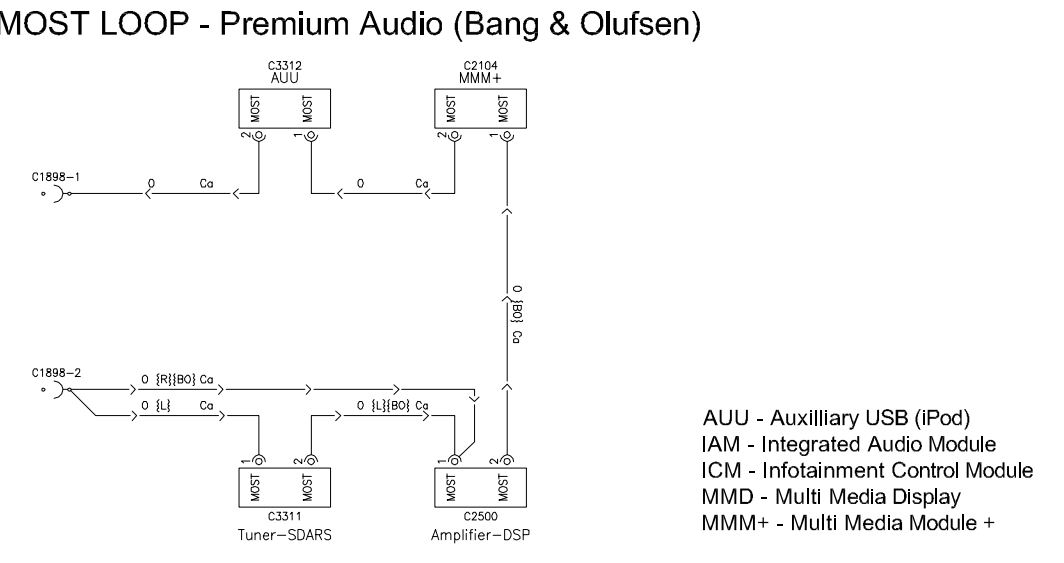
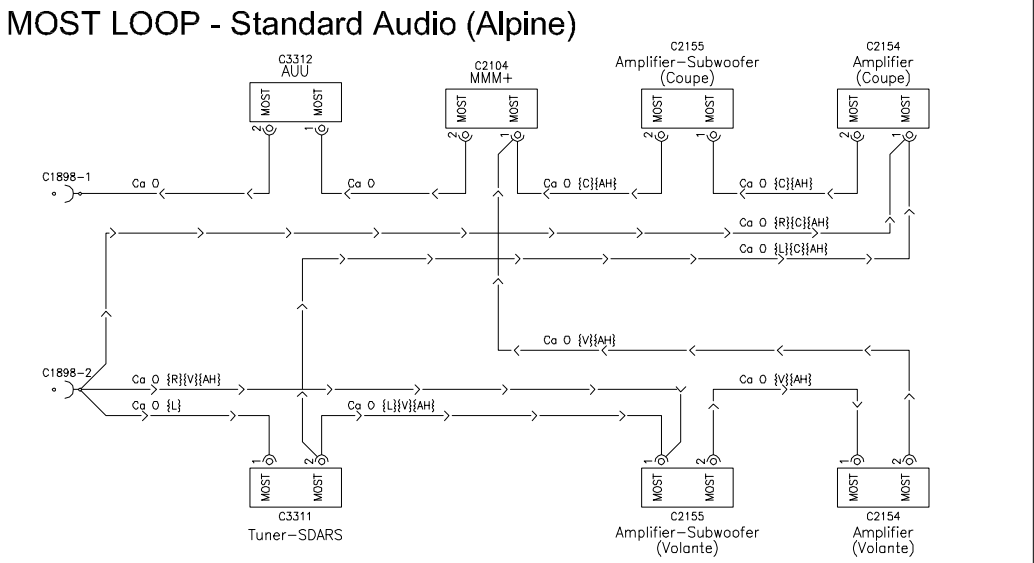
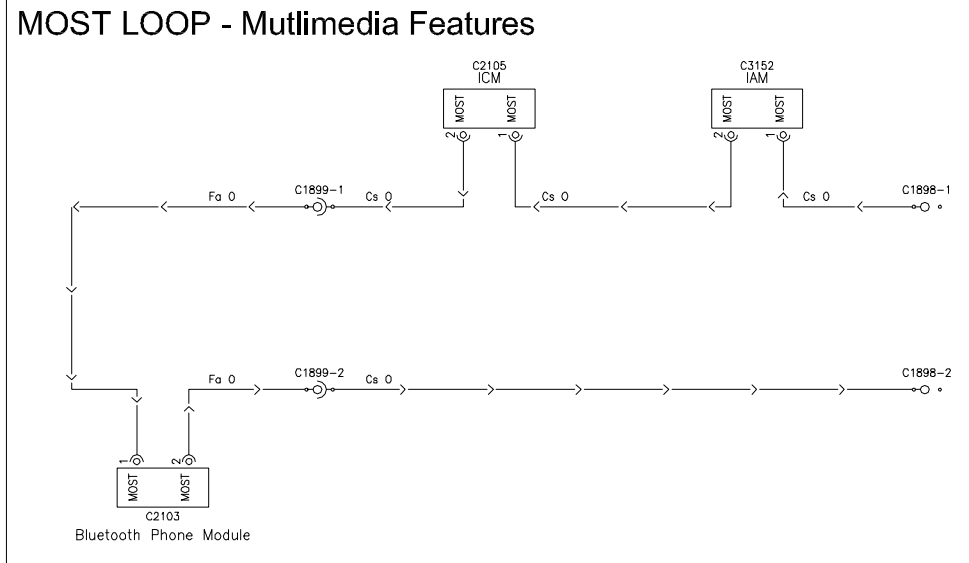
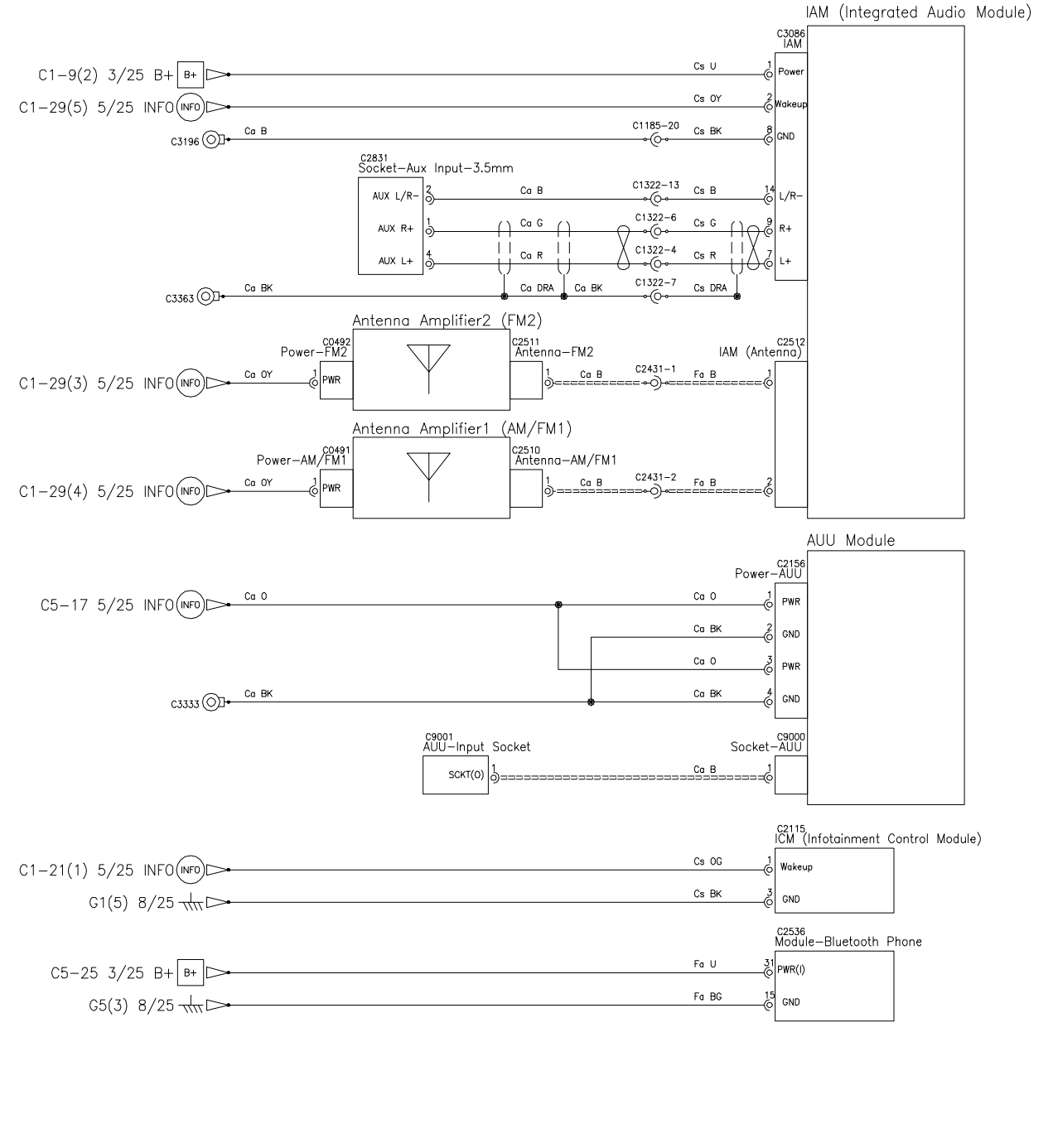
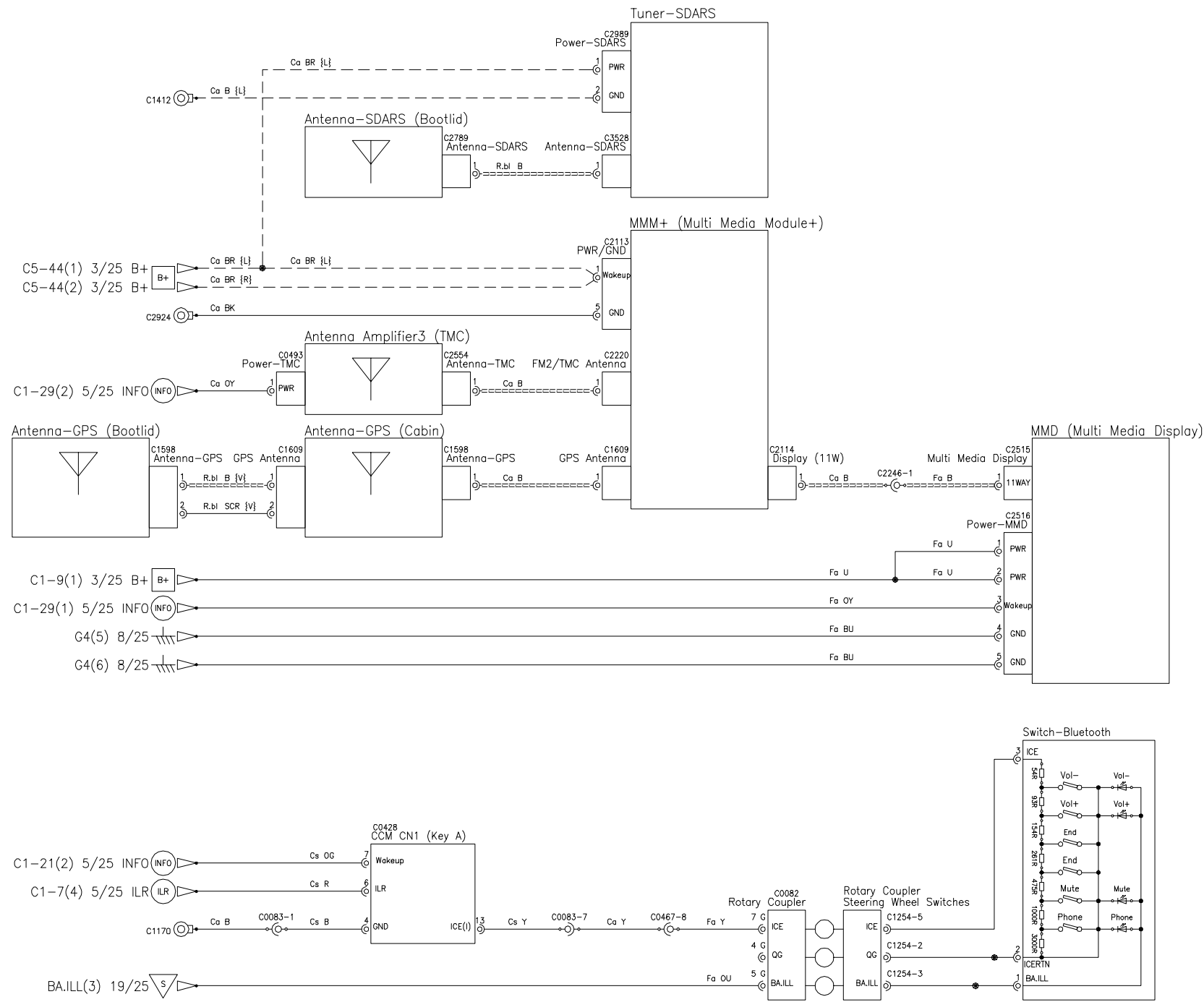

CPSC Code: 00.06.51  
 Prog: DB9 / DBS  
 Build: 2011MY  
 TITLE: SUB-SYSTEM TITLE

# In-Car Entertainment (ICE)

## Standard Multimedia Features

AML DRG No. ILBG43-14T400-AA  
 25 OF 32

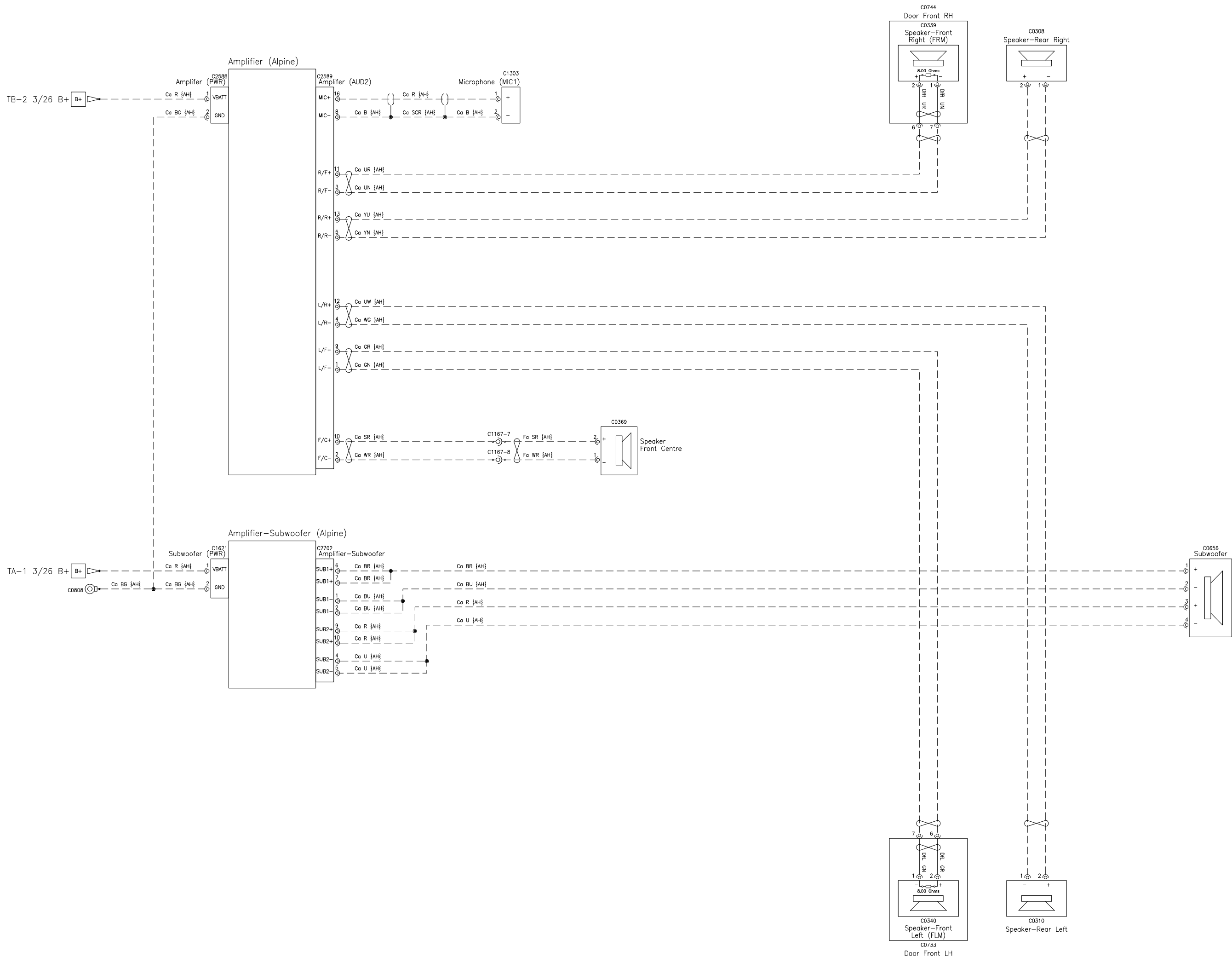

CPSC Code:  
00.06.51

Prog: DB9 / DBS  
Build: 2011MY

TITLE  
SUB-SYSTEM TITLE

# In-Car Entertainment (ICE)

## Standard Audio (Alpine)

AML DRG No.

ILBG43-14T400-AA

26

OF 32

Amplifier (B&O)

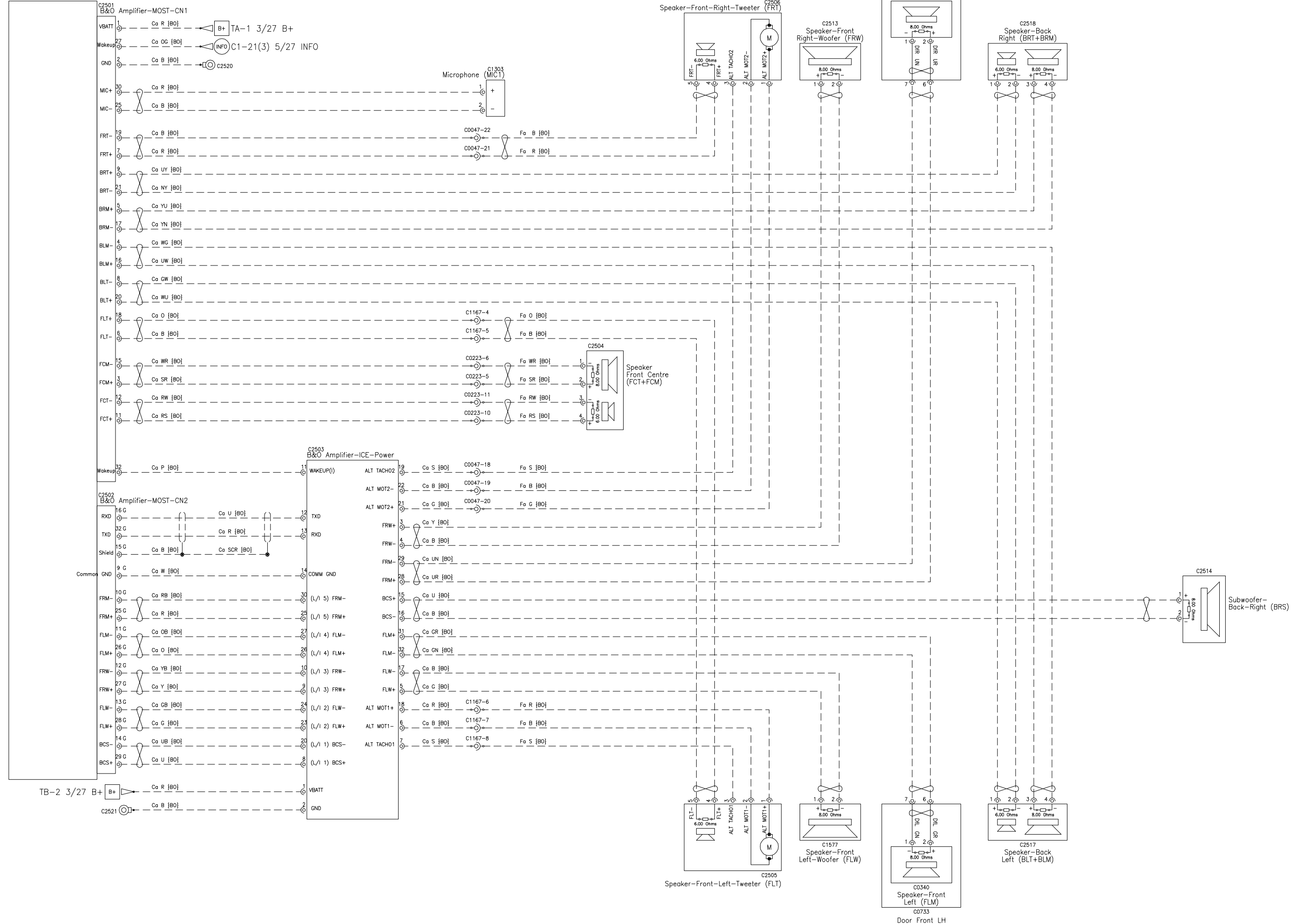

CPSC Code:  
00.06.51

Prog: DB9 / DBS  
Build: 2011MY

TITLE  
SUB-SYSTEM TITLE

In-Car Entertainment (ICE)  
Premium Audio (Bang & Olufsen)

AML DRG No.

ILBG43-14T400-AA

27  
OF 32

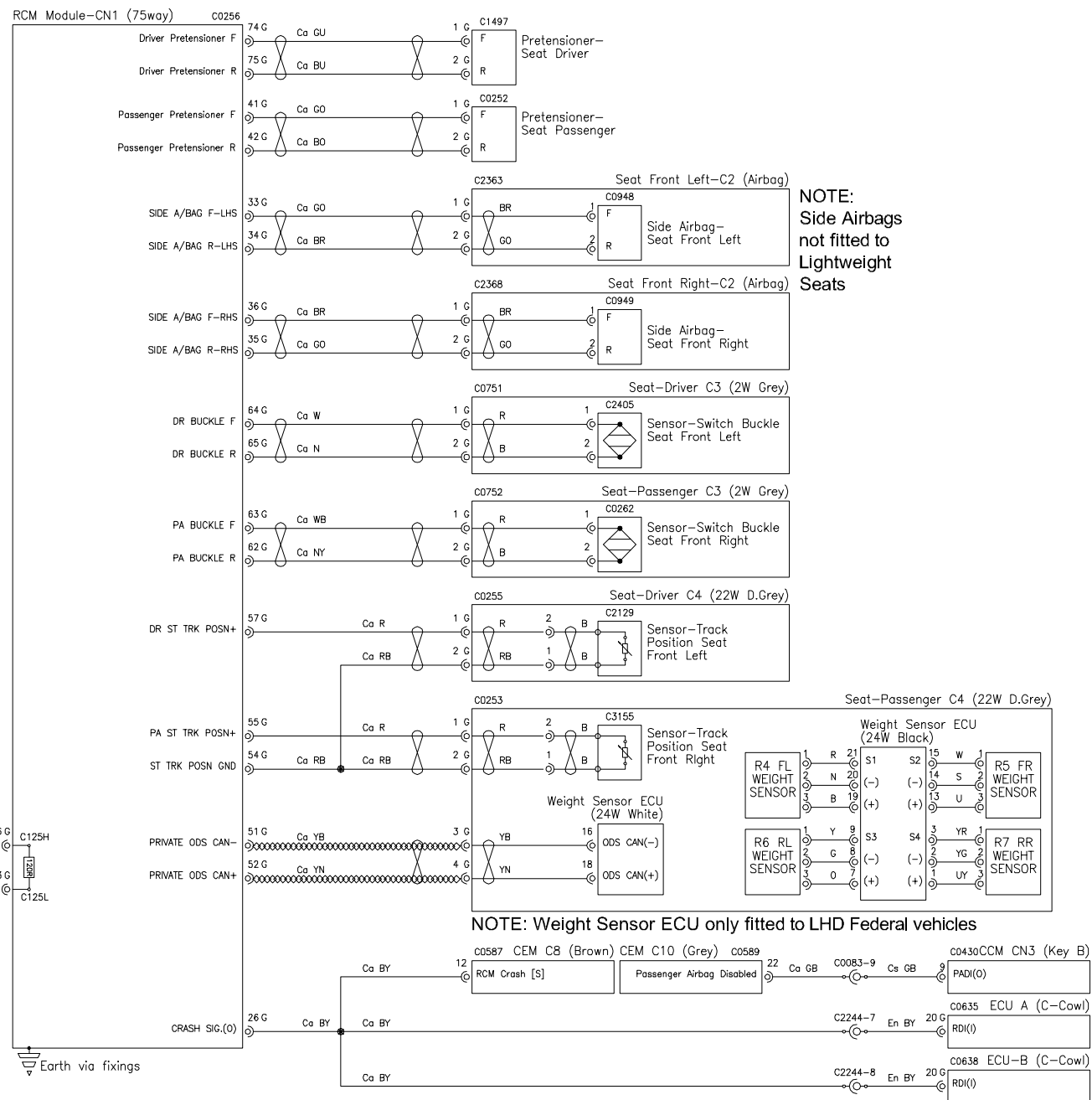
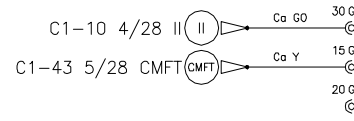
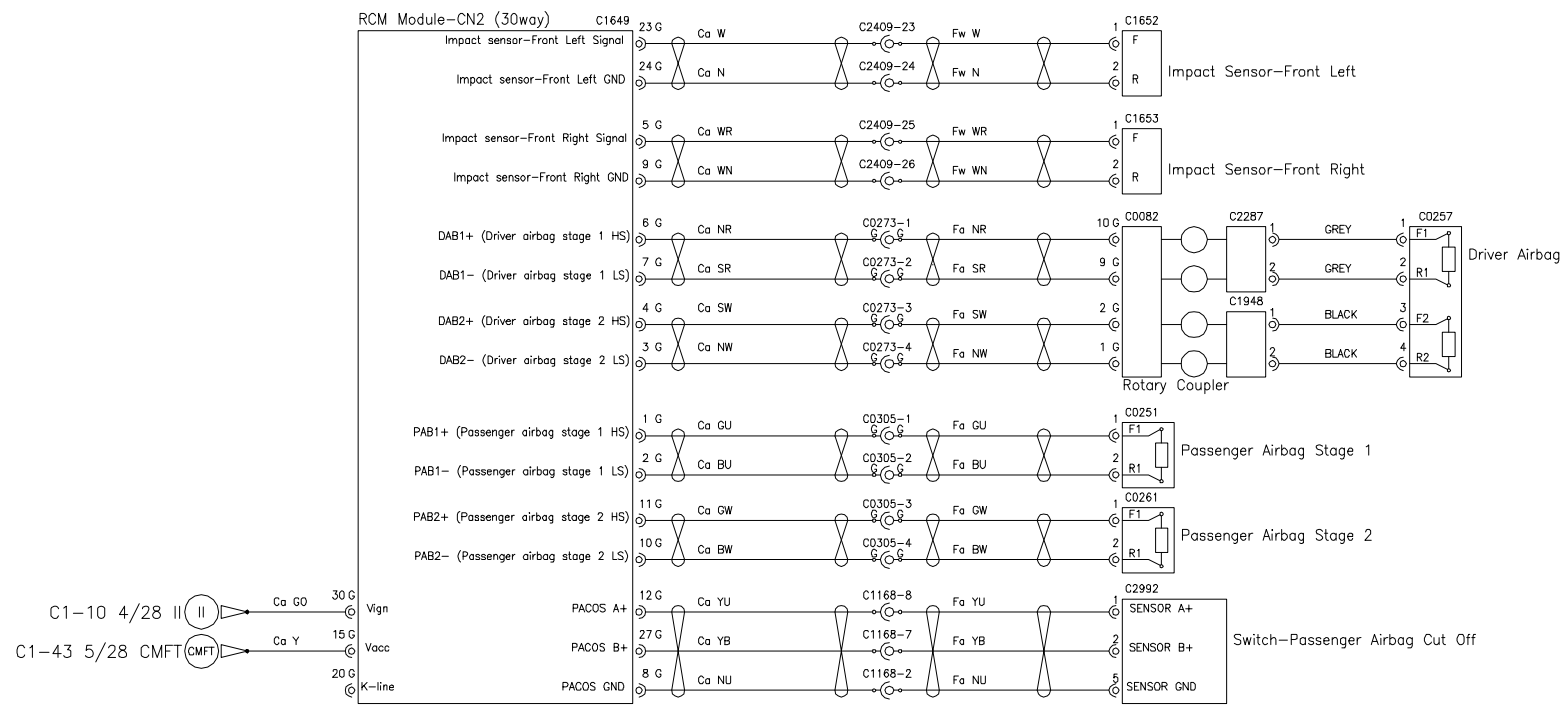

NOTE:  
Side Airbags  
not fitted to  
Lightweight  
Seats

NOTE: Weight Sensor ECU only fitted to LHD Federal vehicles

# Coupe

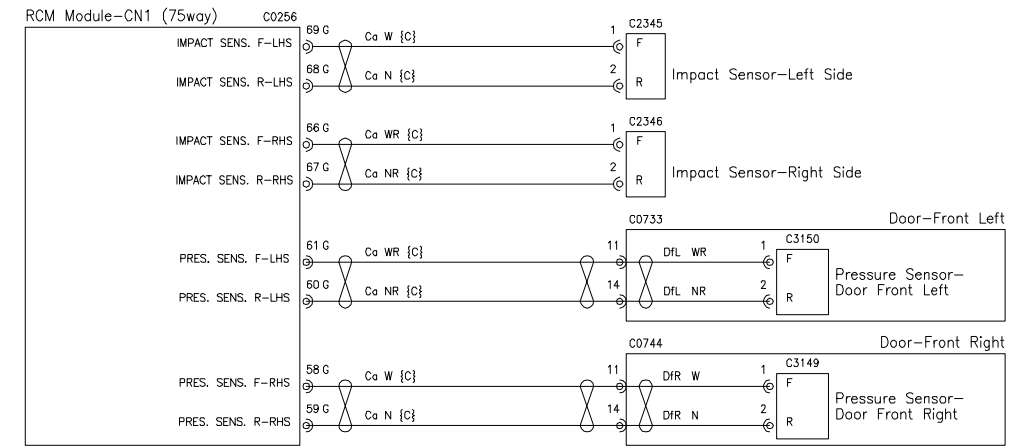

# Volante

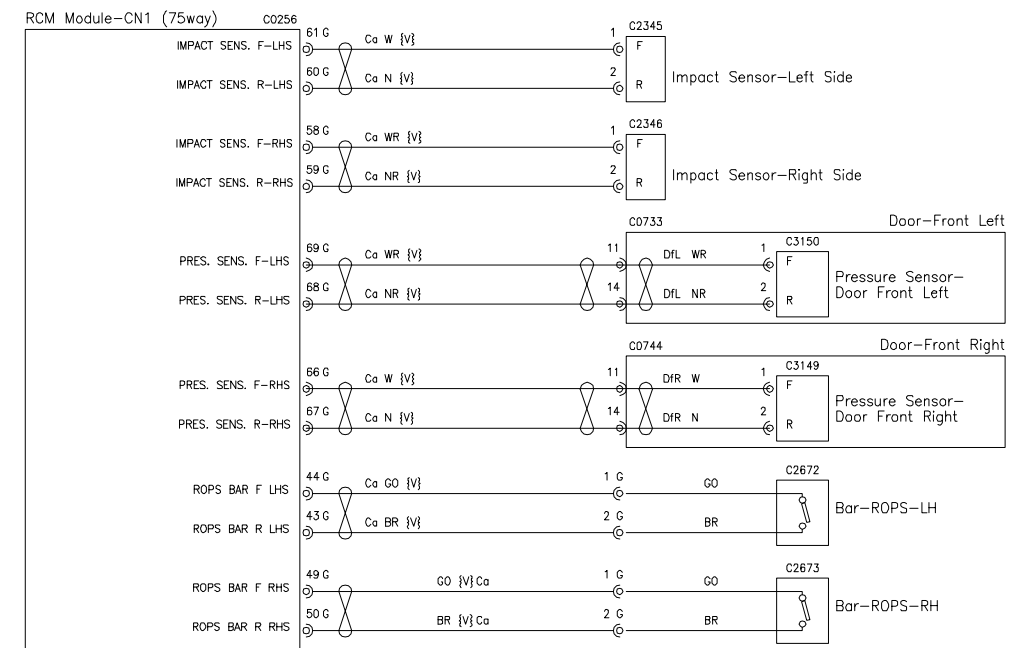

CAN shown on  
Vehicle Network



CPSC Code: 00.06.51  
Prog: DB9 / DBS  
Build: 2011MY

TITLE  
SUB-SYSTEM TITLE

## Supplementary Restraint System

AML DRG No.  
ILBG43-14T400-AA

Parking Aid Module

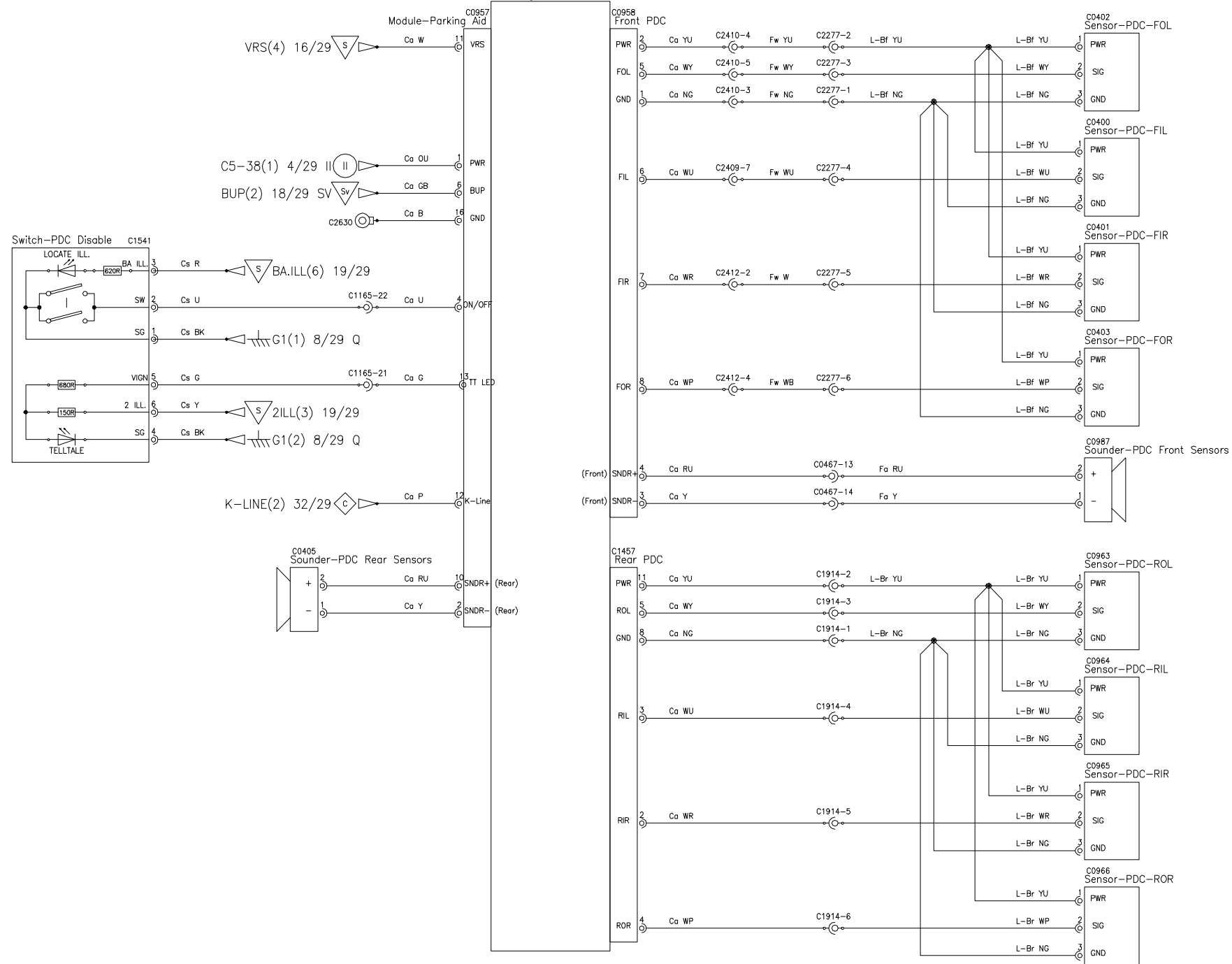

CPSC Code:  
00.06.51

Prog: DB9 / DBS  
Build: 2011MY

TITLE  
SUB-SYSTEM TITLE

Driver Assist  
Reverse Parking Aid System

AML DRG No.

ILBG43-14T400-AA

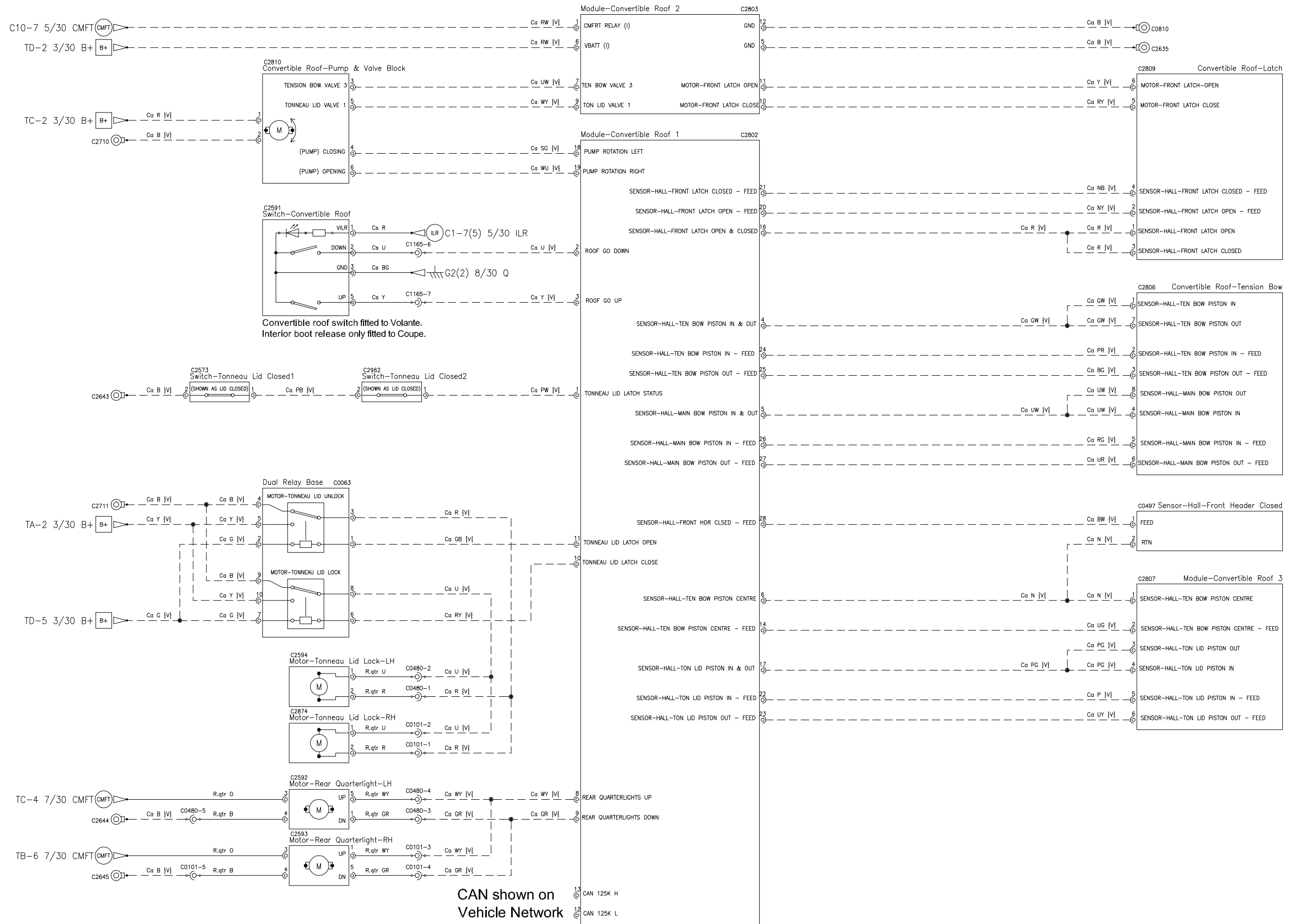

CPSC Code:  
00.06.51

Prog: DB9 / DBS  
Build: 2011MY

TITLE  
SUB-SYSTEM TITLE

# Convertible Roof System Volante Only

AML DRG No.

ILBG43-14T400-AA

30  
OF 32

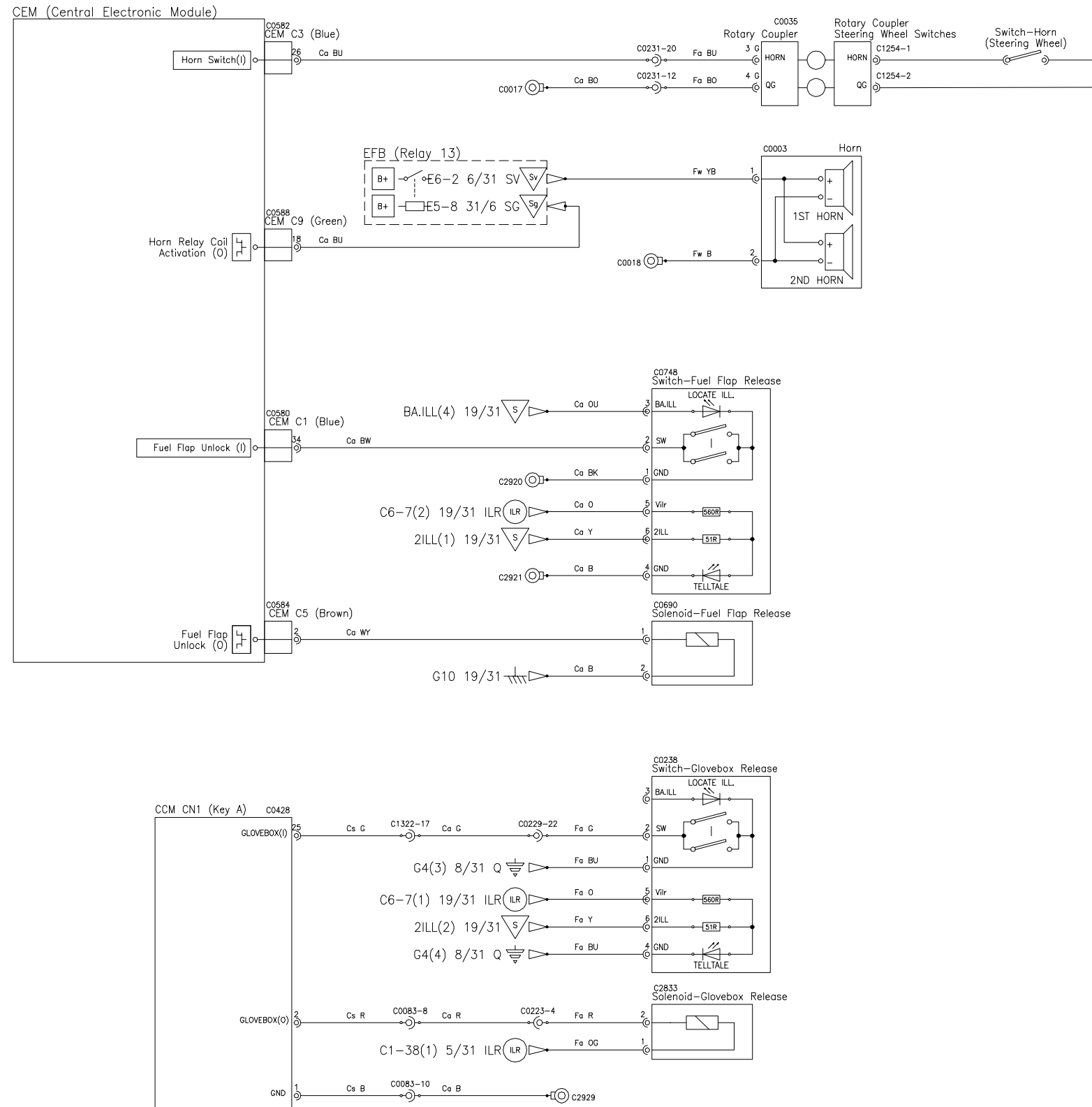

CPSC Code:  
00.06.51

Prog: DB9 / DBS  
Build: 2011MY

TITLE  
SUB-SYSTEM TITLE

## Ancillaries

### Horn, Fuel Flap Release and Glovebox Release

AML DRG No.

ILBG43-14T400-AA

# Body CAN (125K)

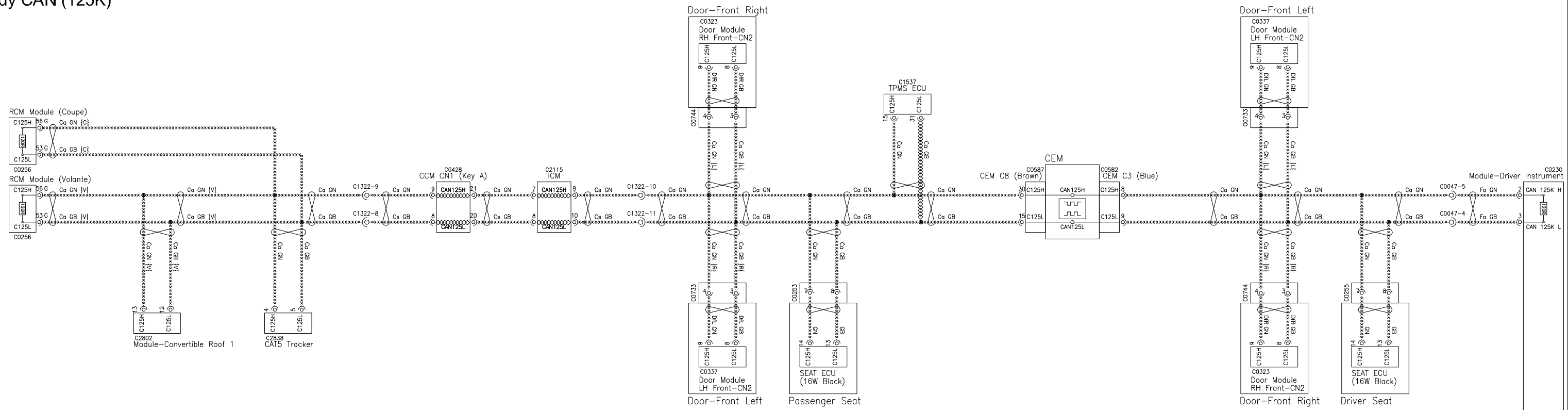

# Powertrain CAN (500K)

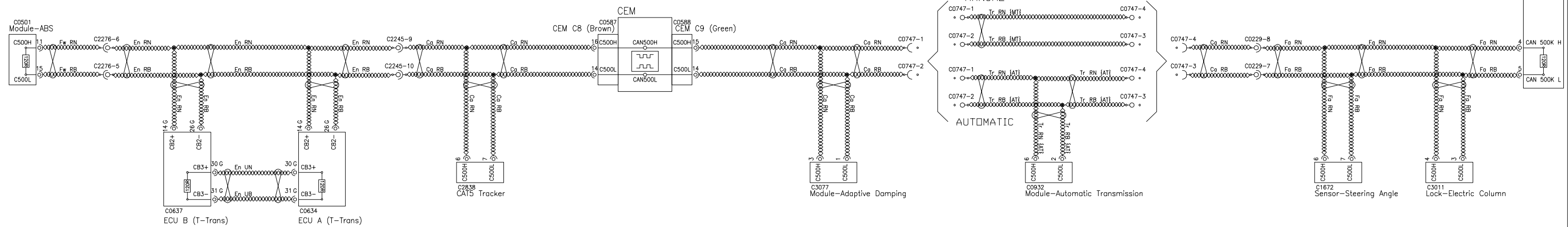

# DIAGNOSTIC CAN

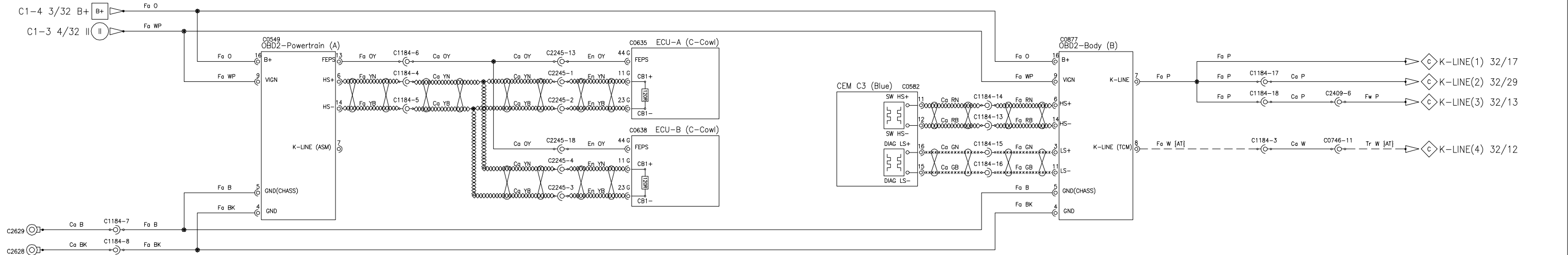

CPSC Code: 00.06.51  
 Prog: DB9 / DBS  
 Build: 2011MY  
 TITLE: SUB-SYSTEM TITLE

## Vehicle Multiplex Systems CAN Networks

AML DRG No. ILBG43-14T400-AA  
 32 OF 32